

ACCESS SERVICE

6. Switched Access Service

6.1 General

Switched Access Service, which is available to customers for their use in furnishing their services to end users, provides a two-point communications path between a customer designated premises and an end user's premises, or when used in conjunction with Internet Protocol Gateway Access Service (IPG) as described in Section 16.4, following, between an IPG SWC and an end user's premises. It provides for the use of common terminating, switching, and trunking facilities and for the use of common subscriber plant of the Telephone Company. Except as specified in Section 6.8.1(M), following, for Feature Group D Switched Access Service used in conjunction with IPG, Switched Access Service provides for the ability to originate calls from an end user's premises to a customer designated premises and to terminate calls from a customer designated premises to an end user's premises in the LATA where it is provided or in another LATA where the customer's traffic is routed to and/or from an access tandem located within the same state or in an adjacent state. Specific references to material describing the elements of Switched Access Service are provided in Sections 6.1.3 and 6.5 through 6.9, following.

(T)  
(C)  
|  
(C)

Rates and charges for Switched Access Service depend generally on the specific Feature Group ordered by the customer, e.g., for MTS or WATS services or MTS/WATS equivalent services, and whether it is provided in a Telephone Company end office that is equipped to provide equal or non-equal access. Rates and charges for Switched Access Service are set forth in Section 17.2, following. The application of rates for Switched Access Service is described in Section 6.4, following. Rates and charges for services other than Switched Access Service, e.g., a customer's interLATA toll message service, may also be applicable when Switched Access Service is used in conjunction with these other services. Descriptions of such applicability are provided in Sections 6.4.5, 6.4.9, 6.5.1(H), 6.5.3, 6.6.1(G), 6.6.2(D), 6.7.1(F) and 6.8.1(E), following. Finally, a credit is applied against line side Switched Access Service charges as described in Section 6.4.8, following.

Transmittal No. 1397

Issued: September 24, 2013

Effective: October 9, 2013

Director - Access Tariffs  
80 So. Jefferson Road, Whippany, NJ 07981

ACCESS SERVICE

(N)

6. Switched Access Service

6.1 General (Cont'd)

The following provision applies to the treatment of Toll VoIP-PSTN Traffic pursuant to the Federal Communications Commission's Part 51 Interconnection Rules and in compliance with the Federal Communications Commission's Report and Order and Further Notice of Proposed Rulemaking in CC Docket Nos. 96-45 and 01-92; GN Docket No. 09-51; WC Docket Nos. 03-109, 05-337, 07-135 and 10-90; and WT Docket No. 10-208, adopted October 27, 2011 and released November 18, 2011 (FCC 11-161). In the absence of an interconnection agreement between the Telephone Company and the customer specifying the treatment of Toll VoIP-PSTN Traffic, the Telephone Company will bill the customer the applicable switched access rates and charges specified in Section 17.2, following, on all jurisdictionally interstate voice traffic identified as Toll VoIP-PSTN Traffic.

(N)

Switched Access Service purchased from the provisions of this tariff may be commingled with unbundled network elements or unbundled network element combinations purchased pursuant to the Commission's Part 51 Interconnection Rules and in compliance with the Federal Communications Commission's Report and Order and Order on Remand and Further Notice of Proposed Rulemaking in CC Docket Nos. 01-338, 96-98 and 98-147, adopted February 20, 2003 and released August 21, 2003 (FCC 03-36).

(M)

(M)

Certain material currently found on this page formerly appeared on 7th Revised Page 6-2.

Transmittal No. 1328

Issued: December 14, 2011

Effective: December 29, 2011

Director - Access Tariffs  
80 So. Jefferson Road, Whippany, NJ 07981

## ACCESS SERVICE

6. Switched Access Service (Cont'd)6.1 General (Cont'd)6.1.1 Description and Provision of Switched Access Service Arrangements(A) Description

Switched Access Service is provided in four different Feature Group arrangements which are service categories of standard and optional features. These are differentiated by their technical characteristics, e.g., line side vs. trunk side connection at the Telephone Company first point of switching. They are also differentiated by optional feature availability and the manner in which the end user accesses them in originating calling, e.g., with or without access codes of various lengths and digits.

Except as provided for in Sections 6.1.3(A)(1) and 6.8.1(M), following, the provision of each Feature Group requires Local Transport facilities, including an Entrance Facility, and the appropriate End Office functions. In addition, Special Access Service may, at the option of the customer, be connected with Feature Groups A, B, C, or D at Telephone Company designated WATS Serving Offices. In addition, IPG may, at the option of the customer, be connected with Feature Group D at Telephone Company designated IPG SWCs.

Certain material formerly found on this page now appears on Original Page 6-1.1.

---

Transmittal No. 1328

Issued: December 14, 2011

Effective: December 29, 2011

Director - Access Tariffs  
80 So. Jefferson Road, Whippany, NJ 07981

ACCESS SERVICE

6. Switched Access Service (Cont'd)

6.1 General (Cont'd)

6.1.1 Description and Provision of Switched Access Service Arrangements (Cont'd)

(A) Description (Cont'd)

Where suitable facilities exist, the Ethernet Switched Access Local Transport (ESALT) option enables the customer to handoff IP formatted traffic to the Telephone Company at the designated end office, host office or tandem office location where the Telephone Company will convert the customer's traffic to TDM format for termination to local exchange service end users over the Telephone Company's local network. This option also enables the Telephone Company to convert traffic originated from its local exchange service end users from TDM format to IP format at the designated end office, host office or tandem office and handoff that IP formatted traffic to the customer designated premises.

(N)  
|  
(N)

There are three specific transmission specifications (i.e., Types A, B and C) that have been identified for the provision of Feature Groups. Except as specified below for ESALT, the technical specifications for the Entrance Facility and Direct Trunked Transport are the same as those set forth in Section 7, following for Voice Grade, High Capacity and Synchronous Optical Channel Services.

(C)

Certain material previously found on this page now appears on Original Page 6-2.3.

Transmittal No. 1403

Issued: November 7, 2013

Effective: November 22, 2013

Director - Access Tariffs  
80 So. Jefferson Road, Whippany, NJ 07981

## ACCESS SERVICE

6. Switched Access Service (Cont'd)6.1 General (Cont'd)6.1.1 Description and Provision of Switched Access Service Arrangements (Cont'd)(A) Description (Cont'd)

The technical specifications for the ESALT Entrance Facility and Direct Trunked Transport are as set forth in the Technical References listed below. The transmission quality of ESALT is not guaranteed and is offered to customers at a best effort level.

- IEEE Standard 802.3 - 2022;
  - IETF RFC 3261 - June 2002;
  - IETF RFC 3262 - June 2002;
  - IETF RFC 3263 - June 2002;
  - IETF RFC 3264 - June 2002;
  - IETF RFC 3265 - June 2002;
  - IETF RFC 3550 - July 2003;
  - ITU-T G.711 - November 1988;
  - ITU-T G.723.1 - May 2006;
  - ITU-T G.729 - June 2012;
  - ITU-T G.7041/Y.1303 - August 2016;
  - ITU-T G.8040/Y.1340 - September 2005;
  - ITU-T H.225.0 - December 2009;
  - ITU-T H.245 - May 2011; and/or
  - ITU-T H.323 - December 2009.
- (T)

---

Transmittal No. 1675

Issued: October 17, 2022

Effective: November 1, 2022

Senior Director - Access Tariff Cost Development  
60 Columbia Road, Bldg. A - 2nd Fl., Morristown, NJ 07960

ACCESS SERVICE

(N)

6. Switched Access Service (Cont'd)

6.1 General (Cont'd)

6.1.1 Description and Provision of Switched Access Service Arrangements (Cont'd)

(A) Description (Cont'd)

(N)

The specifications provided are dependent on the Interface Group and the routing of the service, i.e., whether the service is routed directly to the end office or via an access tandem. The parameters for the transmission specifications are set forth in Section 15.1.2, following.

(M)

Feature Groups are arranged for either originating, terminating or two-way calling, based on the customer end office switching capacity ordered. Originating calling permits the delivery of calls from Telephone Exchange Service locations to the customer designated premises or when used in conjunction with IPG as described in Section 6.8.1(M), following, from Telephone Exchange Service locations to the IPG SWC. Terminating calling permits the delivery of calls from the customer designated premises to Telephone Exchange Service locations or when used in conjunction with IPG as described in Section 6.8.1(M), following, from the IPG SWC to Telephone Exchange Service locations. Two-way calling permits the delivery of calls in both directions, but not simultaneously. The Telephone Company will determine the type of calling to be provided unless the customer requests that a different type of directional calling is to be provided. In such cases, the Telephone Company will work cooperatively with the customer to determine the directionality.

(M)

Certain material currently found on this page previously appeared on 1st Revised Page 6-2.1 and 5th Revised Page 6-3.

Transmittal No. 1403

Issued: November 7, 2013

Effective: November 22, 2013

## ACCESS SERVICE

6. Switched Access Service (Cont'd)6.1 General (Cont'd)6.1.1 Description and Provision of Switched Access Service Arrangements (Cont'd)(A) Description (Cont'd)

There are various optional features associated with Local Transport, Common Switching and Transport Termination available with the Feature Groups. In addition, the Interim NXX Translation and Operator Transfer Service optional features are available with Feature Group C and Feature Group D.

Operator Transfer Services will be provided over FGC or FGD switched access service trunks from the operator service location to the customer's premises. Where required by technical limitations, a separate FGC or FGD trunk group will be established for Operator Transfer Service. The operator service location will provide trunk answer and disconnect supervisory signaling to the customer.

Detailed descriptions of each of the available Feature Groups are set forth in Sections 6.5 through 6.9, following. Each Feature Group is described in terms of its specific physical characteristics and calling capabilities, the optional features available for use with it and the standard testing capabilities.

The Common Switching and Transport Termination optional features, which are described in Section 6.10, following, unless specifically stated otherwise, are available at all Telephone Company end office switches.

Certain material previously found on this page now appears on Original Page 6-2.3.

---

Transmittal No. 1403

Issued: November 7, 2013

Effective: November 22, 2013

Director - Access Tariffs  
80 So. Jefferson Road, Whippany, NJ 07981

## ACCESS SERVICE

6. Switched Access Service (Cont'd)6.1 General (Cont'd)6.1.1 Description and Provision of Switched Access Service Arrangements (Cont'd)(B) Manner of Provision

Switched Access is furnished in either quantities of lines or trunks, or in busy hour minutes of capacity (BHMCs). FGA Access and FGB Access are furnished on a per-line or per-trunk basis respectively. FGC Access and FGD Access are furnished on a BHMC and on a per trunk basis as set forth in Section 5.2, preceding. ESALT may only be used in conjunction with FGD Access. (C)  
(C)

BHMCs are differentiated by type and directionality of traffic carried over a Switched Access Service arrangement. Differentiation of traffic among BHMC types is necessary for the Telephone Company to properly design Switched Access Service to meet the traffic carrying capacity requirement of the customer.

There are three major BHMC categories identified as: Originating, Terminating and Directory Assistance. Originating BHMCs represent access capacity within a LATA for carrying traffic from the end user to the customer or when used in conjunction with Internet Protocol Gateway Access Service, Originating BHMCs represent capacity within the operating territory of the Telephone Company for carrying traffic between the end user and an IPG SWC; Terminating BHMCs represent access capacity within a LATA for carrying traffic from the customer to the end user or when used in conjunction with Internet Protocol Gateway Access Service, Terminating BHMCs represent capacity within the operating territory of the Telephone Company for carrying traffic between the end user and an IPG SWC; and, Directory Assistance BHMCs represent access capacity within a LATA for carrying Directory Assistance traffic from the customer to a Directory Assistance location. When ordering capacity for FGC Access or FGD Access in BHMCs, the customer must at a minimum specify such access capacity in terms of Originating BHMCs and/or Terminating BHMCs.

---

Transmittal No. 1403

Issued: November 7, 2013

Effective: November 22, 2013

Director - Access Tariffs  
80 So. Jefferson Road, Whippany, NJ 07981



ACCESS SERVICE

APPROVED

6. Switched Access Service (Cont'd)

6.1 General (Cont'd)

6.1.1 Description and Provision of Switched Access Service Arrangements (Cont'd)

(B) Manner of Provision (Cont'd)

Because some customers will wish to further segregate their originating traffic into separate trunk groups, or because segregation may be required by network considerations originating BHMCS are further categorized into Domestic, 700, 800 series, 900, Operator, IDDD and Operator Transfer Services. Domestic BHMCS represent access capacity for carrying only domestic traffic other than 700, 800 series, 900, Operator and Operator Transfer Services traffic; IDDD BHMCS represent access capacity for carrying only international traffic; and, 700, 800 series, 900, Operator and Operator Transfer Services BHMCS represent access capacity for carrying, respectively, only 700, 800 series, 900, Operator or Operator Transfer Services traffic. When ordering such types of access capacity, the customer must specify Domestic, 700, 800 series, 900, Operator, IDDD or Operator Transfer Services BHMCS.

6.1.2 Ordering Options and Conditions

Switched Access Service is ordered under the Access Order provisions set forth in 5.2 preceding. Also, included in that section are regulations concerning miscellaneous service order charges which may be associated with Switched Access Service ordering (e.g., Service Date Changes, Cancellations, etc.).

6.1.3 Rate Categories

There are three rate categories which apply to Switched Access Service: (C)

- Local Transport (described in 6.1.3(A) following)
- End Office (described in 6.1.3(B) following)
- Chargeable Optional Features (described in 6.1.3(C) following)

(D)

Transmittal No. 988

Issued: June 16, 2003

Effective: 8 / 10 / 03

Director - Access Tariffs  
80 So. Jefferson Road, Whippany, NJ 07981

ACCESS SERVICE

6. Switched Access Service (Cont'd)

6.1 General (Cont'd)

6.1.3 Rate Categories (Cont'd)

The following diagram depicts a generic view of the components of Switched Access Service and the manner in which the components are combined to provide a complete Access Service.

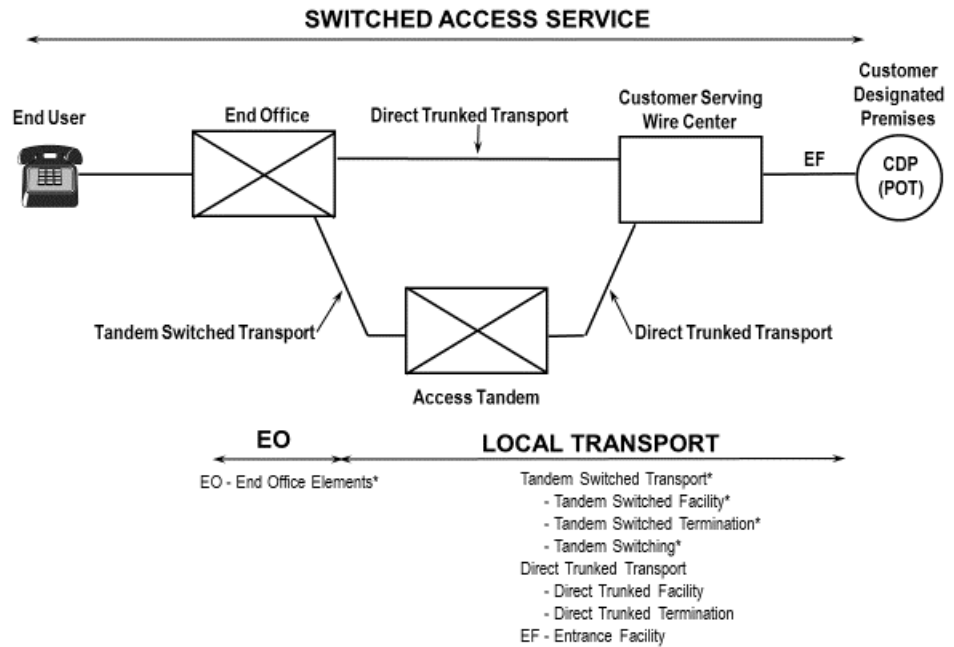

\*As of July 1, 2021, the Joint Tandem Switched Transport rate element in Section 17.2.2, following, is applied per tandem as set forth in Section 6.1.3(A), following, in lieu of the Tandem Switched Facility, Tandem Switched Termination and Tandem Switching rate elements.

(C)  
(C)

Transmittal No. 1694

Issued: June 16, 2023

Effective: July 1, 2023

Senior Director - Access Tariff Cost Development  
 60 Columbia Road, Bldg. A - 2nd Fl., Morristown, NJ 07960

## ACCESS SERVICE

6. Switched Access Service (Cont'd)6.1 General (Cont'd)6.1.3 Rate Categories (Cont'd)(A) Local Transport

The Local Transport rate category establishes the charges related to the transmission and tandem switching facilities between the customer designated premises and the end office switch(es), which may be a Remote Switching Module(s) or WATS Serving Office, where the customer's traffic is switched to originate or terminate the customer's communications. When used in conjunction with IPG as specified in Section 16.4, following, the Local Transport rate category establishes the charges related to the transmission and tandem switching facilities between the IPG SWC and the end office switch(es) to terminate the customer's communications. Mileage measurement rules are set forth in Section 6.4.6, following and in this section.

Local Transport is a two-way voice frequency transmission path composed of facilities determined by the Telephone Company. The two-way voice frequency transmission path permits the transport of calls in the originating direction (from the end user end office switch to the customer designated premises) and in the terminating direction (from the customer designated premises to the end office switch), but not simultaneously. The voice frequency transmission path may be comprised of any form or configuration of plant capable of and typically used in the telecommunications industry for the transmission of voice and associated telephone signals within the frequency bandwidth of approximately 300 to 3000 Hz.

Certain material previously found on this page now appears on 7th Revised Page 6.7.1.

---

Transmittal No. 1403

Issued: November 7, 2013

Effective: November 22, 2013

Director - Access Tariffs  
80 So. Jefferson Road, Whippany, NJ 07981

ACCESS SERVICE

6. Switched Access Service (Cont'd)

6.1 General (Cont'd)

6.1.3 Rate Categories (Cont'd)

(A) Local Transport (Cont'd)

The customer must specify the choice of facilities (i.e., Voice Grade 2 or 4 wire, High Capacity DS1 or DS3, Synchronous Optical Channel OC3 or OC12, or ESALT 2 Mbps, 10 Mbps or 50 Mbps) to be used in the provision of the Direct Trunked Transport or Entrance Facility. High Capacity DS3, Synchronous Optical Channel and ESALT facilities are only available at wire centers identified in NATIONAL EXCHANGE CARRIER ASSOCIATION, INC. TARIFF F.C.C. NO. 4, WIRE CENTER INFORMATION.

(M)  
(T)  
(C)  
(C)  
(C)  
(C)  
(M)

Except when ordering ESALT or Local Transport associated with IPG, the customer must specify when ordering: (1) whether the service is to be directly routed to an end office switch or through an access tandem switch, (2) the type of Direct Trunked Transport and whether it will overflow to Tandem Switched Transport when service is directly routed to an end office, (3) the type of Entrance Facility, where applicable, (4) the directionality of the service, and (5) when multiplexing is required, the hub(s) at which the multiplexing will be provided.

(C)

Certain material currently found on this page previously appeared on 7th Revised Page 6-7.

Certain material previously found on this page now appears on Original Page 6-7.1.1.

Transmittal No. 1403

Issued: November 7, 2013

Effective: November 22, 2013

Director - Access Tariffs  
80 So. Jefferson Road, Whippany, NJ 07981

ACCESS SERVICE

(N)

6. Switched Access Service (Cont'd)

6.1 General (Cont'd)

6.1.3 Rate Categories (Cont'd)

(A) Local Transport (Cont'd)

When ordering ESALT, the customer must specify:  
(1) the ESALT-equipped SWC and (2) the end office switch(es) to which the customer wants to terminate interexchange voice traffic originated on its IP based network and/or receive interexchange voice traffic originated on the Telephone Company's network.

(N)

When ordering Local Transport associated with IPG, the customer must specify:  
(1) the IPG SWC and (2) the end office switch(es) to which the IPG customer wants to terminate interexchange voice traffic originated on its IP based network and/or receive interexchange voice traffic originated on the Telephone Company's network.

(M)  
(C)

When the customer has both Tandem Switched Transport and Direct Trunked Transport at the same end office, the customer will be provided Alternate Traffic Routing as set forth in Section 6.4.6, following.

(M)

Certain material currently found on this page previously appeared on 6th Revised Page 6-7.1.

Transmittal No. 1403

Issued: November 7, 2013

Effective: November 22, 2013

Director - Access Tariffs  
80 So. Jefferson Road, Whippany, NJ 07981

ACCESS SERVICE

6. Switched Access Service (Cont'd)

6.1 General (Cont'd)

6.1.3 Rate Categories (Cont'd)

(A) Local Transport (Cont'd)

Except as specified above for High Capacity DS3, Synchronous Optical Channel and Ethernet Switched Access Local Transport, Direct Trunked Transport is available at all tandems and at all end offices except those end offices identified in NATIONAL EXCHANGE CARRIER ASSOCIATION, INC. TARIFF F.C.C. NO. 4, as not having the capability to provide Direct Trunked Transport. Direct Trunked Transport is not available: (1) from end offices that provide equal access through a Centralized Equal Access arrangement, or (2) from end offices that lack recording or measurement capability.

(C)  
|  
(C)  
|  
(M)  
|  
(M)

Normally, Direct Trunked Transport of originating 800 series calls from an end office is available only from Service Switching Point (SSP) equipped end offices. However, certain SSP equipped end offices cannot accommodate the direct trunking of the 800 series (other than the 800 service access code) service access code. These end offices are identified in NATIONAL EXCHANGE CARRIER ASSOCIATION, INC., TARIFF F.C.C. NO. 4. Additionally, certain non-SSP equipped end offices can accommodate direct trunking of originating 800 series calls. These end offices are also identified in NATIONAL EXCHANGE CARRIER ASSOCIATION, INC., TARIFF F.C.C. NO. 4.

Certain material currently found on this page previously appeared on 6th Revised Page 6-7.1.

Transmittal No. 1403

Issued: November 7, 2013

Effective: November 22, 2013

Director - Access Tariffs  
80 So. Jefferson Road, Whippany, NJ 07981

ACCESS SERVICE

6. Switched Access Service (Cont'd)

6.1 General (Cont'd)

6.1.3 Rate Categories (Cont'd)

(A) Local Transport (Cont'd)

Unless otherwise ordered by the F.C.C., where the Telephone Company elects to provide equal access through a Centralized Equal Access arrangement, the Telephone Company will designate the serving wire center. The designated SWC will normally be that wire center which provides dial tone to the telephone company Centralized Equal Access tandem office identified in NATIONAL EXCHANGE CARRIER ASSOCIATION, INC. TARIFF F.C.C. NO. 4. When service is provided in cooperation with a non telephone company provider of Centralized Equal Access, the SWC will be that wire center which would normally provide dial tone to the telephone company point of interconnection with the non telephone company provider of Centralized Equal Access specified in the tariff of the Centralized Equal Access provider. Those Telephone Company offices providing equal access through centralized arrangements are identified in NATIONAL EXCHANGE CARRIER ASSOCIATION, INC. TARIFF F.C.C. NO. 4.

(N)  
|  
(N)  
|  
(M)  
|  
(M)

Certain material currently found on this page previously appeared on 1st Revised Page 6-7.2.

Transmittal No. 1257

Issued: November 13, 2009

Effective: *April 14, 2010*

Director - Access Tariffs  
80 So. Jefferson Road, Whippany, NJ 07981

ACCESS SERVICE

6. Switched Access Service (Cont'd)

6.1 General (Cont'd)

6.1.3 Rate Categories (Cont'd)

(A) Local Transport (Cont'd)

Local Transport is provided at the rates and charges set forth in Section 17.2, following. (T)  
 The application of these rates with respect to individual Feature Groups is as set forth in Section 6.4.1(C), following. When (T)  
 more than one Telephone Company is involved in providing the Switched Access Service, the Local Transport rates are applied as set forth in Section 2.4.7, preceding. (T)

The Local Transport rate category includes the following elements as described below: (T)  
 (C)

- (1) Entrance Facility, (2) Direct Trunked Transport, (3) Tandem Switched Transport, (T)
- (4) Multiplexing, (5) Add/Drop Multiplexing, (C)
- (6) Customer Node, (7) Interface Groups, |
- (8) Nonchargeable Optional Features and |
- (9) Chargeable Optional Features. (C)

(1) Entrance Facility

The Entrance Facility recovers a portion of the costs associated with a communications path between a customer designated premises and the serving wire center of that premises. Included as part of the Entrance Facility is a standard channel interface arrangement which defines the technical characteristics associated with the type of facilities to which the access service is to be connected at the customer designated premises and the type of signaling capability, if any.

Transmittal No. 1403

Issued: November 7, 2013

Effective: November 22, 2013

Director - Access Tariffs  
 80 So. Jefferson Road, Whippany, NJ 07981



ACCESS SERVICE

6. Switched Access Service (Cont'd)

6.1 General (Cont'd)

6.1.3 Rate Categories (Cont'd)

(A) Local Transport (Cont'd)

(1) Entrance Facility (Cont'd)

Eight types of Entrance Facility are available: (C)

- Voice Grade 2 or 4 wire -  
an analog channel with an  
approximate bandwidth of 300 to  
3000 Hz;
- High Capacity DS1 -  
an isochronous serial digital  
channel with a rate of 1.544 Mbps;
- High Capacity DS3 -  
an isochronous serial digital  
channel with a rate of 44.736 Mbps;
- Synchronous Optical Channel OC3 -  
a synchronous optical channel with a  
rate of 155.52 Mbps;
- Synchronous Optical Channel OC12 -  
a synchronous optical channel with a  
rate of 622.08 Mbps;
- ESALT 2 Mbps - an Ethernet packet  
based channel with a rate of 2 Mbps;
- ESALT 10 Mbps - an Ethernet packet  
based channel with a rate of 10 Mbps;
- ESALT 50 Mbps - an Ethernet packet  
based channel with a rate of 50 Mbps.

(T)  
(N)  
|  
(N)

Certain material previously found on this page now appears on 2nd Revised Page 6-8.1.1.

Transmittal No. 1403

Issued: November 7, 2013

Effective: November 22, 2013

Director - Access Tariffs  
80 So. Jefferson Road, Whippany, NJ 07981



ACCESS SERVICE

(N)

6. Switched Access Service (Cont'd)

6.1 General (Cont'd)

6.1.3 Rate Categories (Cont'd)

(A) Local Transport (Cont'd)

(1) Entrance Facility (Cont'd)

(N)

The Telephone Company specific rate band assignment for the Entrance Facility rate element is specified in the Local Transport (LT) column in Section 17.5.1, following.

(M)

A customer's Local Transport may be connected to the Entrance Facility of another customer, providing the other customer submits a Letter of Authorization for this connection and assumes full responsibility for the cost of the Entrance Facility.

(M)

Certain material currently found on this page previously appeared on 1st Revised Page 6-8.1.1.

Transmittal No. 1403

Issued: November 7, 2013

Effective: November 22, 2013

Director - Access Tariffs  
80 So. Jefferson Road, Whippany, NJ 07981

ACCESS SERVICE

6. Switched Access Service (Cont'd)

6.1 General (Cont'd)

6.1.3 Rate Categories (Cont'd)

(A) Local Transport (Cont'd)

(2) Direct Trunked Transport

The Direct Trunked Transport rate elements recover a portion of the cost associated with a communications path or circuits dedicated to the use of a single customer between:

- the serving wire center and an end office,
- the serving wire center and a tandem,
- the serving wire center and a hub,
- a hub and an end office,
- the serving wire center and an ADM equipped wire center where add/drop multiplexing functions are performed,
- an ADM equipped wire center and an end office.

Except as specified above for High Capacity DS3, Synchronous Optical Channel and Ethernet Switched Access Local Transport, Direct Trunked Transport is available at all tandems and to all end offices except those end offices identified in NATIONAL EXCHANGE CARRIER ASSOCIATION, INC. TARIFF F.C.C. NO. 4, WIRE CENTER INFORMATION as not having the capability to provide Direct Trunked Transport.

(C)  
|  
(C)

Direct Trunked Transport is not available: (1) from end offices that provide equal access through a Centralized Equal Access arrangement or (2) from end offices that lack recording or measurement capability.

Transmittal No. 1403

Issued: November 7, 2013

Effective: November 22, 2013

ACCESS SERVICE

6. Switched Access Service (Cont'd)

6.1 General (Cont'd)

6.1.3 Rate Categories (Cont'd)

(A) Local Transport (Cont'd)

(2) Direct Trunked Transport (Cont'd)

Normally, Direct Trunked Transport of originating 800 series calls from an end office is available only from Service Switching Point (SSP) equipped end offices. However, certain SSP equipped end offices cannot accommodate the direct trunking of the 800 series (other than the 800 service access code) service access code. These end offices are identified in NATIONAL EXCHANGE CARRIER ASSOCIATION, INC., TARIFF F.C.C. NO. 4. Additionally, certain non-SSP equipped end offices can accommodate direct trunking of originating 800 series calls. These end offices are also identified in NATIONAL EXCHANGE CARRIER ASSOCIATION, INC., TARIFF F.C.C. NO. 4.

Certain material previously found on this page now appears on 1st Revised Page 6-8.3.1.

Transmittal No. 1403

Issued: November 7, 2013

Effective: November 22, 2013

Director - Access Tariffs  
80 So. Jefferson Road, Whippany, NJ 07981

ACCESS SERVICE

6. Switched Access Service (Cont'd)

6.1 General (Cont'd)

6.1.3 Rate Categories (Cont'd)

(A) Local Transport (Cont'd)

(2) Direct Trunked Transport (Cont'd)

Eight types of Direct Trunked Transport are available:

- Voice Grade 2 or 4 wire - an analog channel with an approximate bandwidth of 300 to 3000 Hz;
- High Capacity DS1 - an isochronous serial digital channel with a rate of 1.544 Mbps;
- High Capacity DS3 - an isochronous serial digital channel with a rate of 44.736 Mbps;
- Synchronous Optical Channel OC3 - a synchronous optical channel with a rate of 155.52 Mbps;
- Synchronous Optical Channel OC12 - a synchronous optical channel with a rate of 622.08 Mbps;
- ESALT 2 Mbps - an Ethernet packet based channel with a rate of 2 Mbps;
- ESALT 10 Mbps - an Ethernet packet based channel with a rate of 10 Mbps;
- ESALT 50 Mbps - an Ethernet packet based channel with a rate of 50 Mbps.

(C) (M)

(T) (M)

(N)

(N)

Certain material currently found on this page previously appeared on 5<sup>th</sup> Revised Page 6-8.3.

Certain material previously found on this page now appears on Original Page 6-8.3.2.

Transmittal No. 1403

Issued: November 7, 2013

Effective: November 22, 2013

Director - Access Tariffs  
80 So. Jefferson Road, Whippany, NJ 07981

ACCESS SERVICE

(N)

6. Switched Access Service (Cont'd)

6.1 General (Cont'd)

6.1.3 Rate Categories (Cont'd)

(A) Local Transport (Cont'd)

(2) Direct Trunked Transport (Cont'd)

(N)

High Capacity DS3 Direct Trunked Transport can not be terminated at end offices that are not identified as hub offices that provide DS3 to DS1 multiplexing.

(M)

Synchronous Optical Channel Service OC3 or OC12 Direct Trunked Transport can not be terminated at end offices that are not identified as ADM equipped wire centers that provide OC3 to DS1 or OC12 to OC3 Add/Drop Multiplexing.

(M)

ESALT 2 Mbps, 10 Mbps or 50 Mbps Direct Trunked Transport can not be terminated at end offices, host offices or tandem offices that are not identified as ESALT-equipped wire centers in NATIONAL EXCHANGE CARRIER ASSOCIATION, INC. TARIFF F.C.C. NO. 4, WIRE CENTER INFORMATION.

(N)

(N)

Additionally, DS1 Direct Trunked Transport can not be terminated at end offices that are not identified as hub offices that provide DS1 to Voice Grade multiplexing or are not electronic end offices.

Offices that provide multiplexing and add/drop multiplexing functions are identified in NATIONAL EXCHANGE CARRIER ASSOCIATION, INC. TARIFF F.C.C. NO. 4, WIRE CENTER INFORMATION.

Certain material currently found on this page previously appeared on Original Page 6-8.3.1.

Transmittal No. 1403

Issued: November 7, 2013

Effective: November 22, 2013

Director - Access Tariffs  
80 So. Jefferson Road, Whippany, NJ 07981

ACCESS SERVICE

6. Switched Access Service (Cont'd)

6.1 General (Cont'd)

6.1.3 Rate Categories (Cont'd)

(A) Local Transport (Cont'd)

(2) Direct Trunked Transport (Cont'd)

Except as specified below for ESALT, Direct Trunked Transport rates consist of a Direct Trunked Facility rate specified in Section 17.2.2, following, which is applied on a per mile basis, and a Direct Trunked Termination rate, which is applied at each end of each measured segment of the Direct Trunked Facility (e.g., at the end office, tandem, hub, ADM equipped wire center, and serving wire center).

(C)

Direct Trunked Transport rates for ESALT consist of: 1) an ESALT Direct Trunked Facility (DTF) rate specified in Section 17.2, following, which is applied on a per facility basis based on the capacity ordered by the customer (i.e., 2 Mbps, 10 Mbps or 50 Mbps) and on whether the ESALT DTF is provided entirely within the Telephone Company's operating territory or jointly provided with another telephone company to a serving wire center located outside of the Telephone Company's operating territory and 2) an ESALT Direct Trunked Termination (DTT) rate specified in Section 17.2, following, which is applied at each end of the ESALT DTF (i.e., at the serving wire center serving the customer's designated premises and

(N)

(N)

Certain material previously found on this page now appears on Original Page 6-8.4.2 and Original Page 6-8.4.3.

Transmittal No. 1403

Issued: November 7, 2013

Effective: November 22, 2013

Director - Access Tariffs  
80 So. Jefferson Road, Whippany, NJ 07981



ACCESS SERVICE

(N)

6. Switched Access Service (Cont'd)

6.1 General (Cont'd)

6.1.3 Rate Categories (Cont'd)

(A) Local Transport (Cont'd)

(2) Direct Trunked Transport (Cont'd)

either the end office, host office, or tandem office) at the same capacity as the capacity of the associated ESALT Direct Trunked Facility segment.

The type of ESALT Direct Trunked Facility required will depend upon the configuration of the customer's service as follows:

- ESALT DTF-E1 is required when the ESALT SWC and SWC serving the customer designated premises are located within the Telephone Company's operating territory.
- ESALT DTF-E2 is required when the customer designated premises is located outside of the Telephone Company's operating territory in an adjacent operating territory and the ESALT is jointly provided with another telephone company.

(N)

Transmittal No. 1403

Issued: November 7, 2013

Effective: November 22, 2013

Director - Access Tariffs  
80 So. Jefferson Road, Whippany, NJ 07981

ACCESS SERVICE

(N)

6. Switched Access Service (Cont'd)

6.1 General (Cont'd)

6.1.3 Rate Categories (Cont'd)

(A) Local Transport (Cont'd)

(2) Direct Trunked Transport (Cont'd)

- ESALT DTF-E3 is required when the customer designated premises is located outside of the Telephone Company's operating territory in a non-adjacent operating territory where the airline distance between the ESALT SWC and SWC serving the customer designated premises is 50 airline miles or less and the ESALT is jointly provided with another telephone company.
- ESALT DTF-E4 is required when the customer designated premises is located outside of the Telephone Company's operating territory in a non-adjacent operating territory where the airline distance between the ESALT SWC and SWC serving the customer designated premises is between 51 and 75 airline miles and the ESALT is jointly provided with another telephone company. When the customer designated premises is located in a non-adjacent operating territory, ESALT is not available when the airline distance between the SWC serving the customer designated premises and the ESALT SWC is greater than 75 airline miles.

(N)

Transmittal No. 1403

Issued: November 7, 2013

Effective: November 22, 2013

Director - Access Tariffs  
80 So. Jefferson Road, Whippany, NJ 07981



ACCESS SERVICE

6. Switched Access Service (Cont'd)

6.1 General (Cont'd)

6.1.3 Rate Categories (Cont'd)

(A) Local Transport (Cont'd)

(3) Tandem Switched Transport

The Tandem Switched Transport rate elements recover a portion of the costs associated with a communications path between a tandem and an end office on circuits that are switched at a tandem switch.

Tandem Switched Transport rates consist of a Tandem Switching rate, a Tandem Switched Facility rate, and a Tandem Switched Termination rate. For originating toll free minutes only, a Joint Tandem Switched Transport rate applies in lieu of the Tandem Switching, Tandem Switched Facility and Tandem Switched Termination rates and is only billed by the tandem company that performs the tandem switching function.

(C)  
|  
(C)

In those instances where an SSP equipped end office is capable of handling 800 traffic on a direct trunked basis but incapable of handling 800 series (other than the 800 service access code) traffic on a direct trunked basis, a full credit will be provided for tandem switched transport charges associated with FGC and FGD service for 800 series traffic delivered at the tandem. This results in all 800 series traffic being rated as direct trunked transport regardless of whether the SSP equipped end office is capable of handling 800 series (other than the 800 service access code) traffic on a direct trunked basis. Those SSP equipped end offices that cannot accommodate direct

(T)

Certain material formerly found on this page now appears on Original Page 6-8.6.

Transmittal No. 1635

Issued: June 16, 2021

Effective: July 1, 2021

Senior Director - Access Tariffs & Costs  
60 Columbia Road, Bldg. A - 2nd Fl., Morristown, NJ 07960

ACCESS SERVICE

6. Switched Access Service (Cont'd)

6.1 General (Cont'd)

6.1.3 Rate Categories (Cont'd)

(A) Local Transport (Cont'd)

(3) Tandem Switched Transport

trunking of originating 800 series (other than the 800 service access code) traffic are identified in NECA TARIFF F.C.C. NO. 4, WIRE CENTER INFORMATION.

(a) The Tandem Switching rate recovers a portion of the costs of switching traffic through an access tandem. The Tandem Switching rate specified in 17.2.2 following is applied on a per access minute per tandem basis for all originating (excluding toll free) and all terminating minutes of use switched at the tandem. Tandem locations are identified in NATIONAL EXCHANGE CARRIER ASSOCIATION, INC. TARIFF F.C.C. NO. 4, WIRE CENTER INFORMATION.

(b) The Tandem Switched Facility rate recovers a portion of the costs of transmission facilities, including intermediate transmission circuit equipment, between the end points of interoffice circuits. The Tandem Switched Facility rate specified in 17.2.2 following is applied on a per access minute per mile basis for all originating (excluding toll free) and terminating minutes of use routed over the facility.

(c) The Tandem Switched Termination rate recovers a portion of the costs of circuit equipment necessary for the termination of each end of each measured segment of the Tandem

(N)

(N)

(M)

(C)

(C)

(M)

Certain material currently found on this page previously appeared on 2nd Revised Page 6-8.5 and 11th Revised Page 6-9.

Transmittal No. 1635

Issued: June 16, 2021

Effective: July 1, 2021

Senior Director - Access Tariffs & Costs  
60 Columbia Road, Bldg. A - 2nd Fl., Morristown, NJ 07960

ACCESS SERVICE

6. Switched Access Service (Cont'd)

6.1 General (Cont'd)

6.1.3 Rate Categories (Cont'd)

(A) Local Transport (Cont'd)

(3) Tandem Switched Transport (Cont'd)

Switched Facility. The Tandem Switched Termination rate specified in 17.2.2 following is applied on a per access minute basis (for all originating (excluding toll free) and terminating minutes of use routed over the facility) at each end of each measured segment of Tandem Switched Facility (e.g., at the end office, Feature Group A dial tone office, host office and the access tandem). When the Tandem Switched Facility mileage is zero, neither the Tandem Switched Facility rate nor the Tandem Switched Termination rate will apply.

(C)

(d) The Joint Tandem Switched Transport rate specified in Section 17.2.2, following, is applied on a per originating toll free access minute per tandem basis in lieu of the Tandem Switching, Tandem Switched Facility, and Tandem Switched Termination rates and is only billed by the tandem company that performs the tandem switching function.

(N)

(N)

The Telephone Company specific rate band assignment for the Tandem Switched Transport rate elements is specified in the Tandem Switched Transport (TST) column in Section 17.5.1, following.

Certain material formerly found on this page now appears on Original Page 6-8.6.

Transmittal No. 1635

Issued: June 16, 2021

Effective: July 1, 2021

Senior Director - Access Tariffs & Costs  
60 Columbia Road, Bldg. A - 2nd Fl., Morristown, NJ 07960

## ACCESS SERVICE

6. Switched Access Service (Cont'd)6.1 General (Cont'd)6.1.3 Rate Categories (Cont'd)(A) Local Transport (Cont'd)(4) Multiplexing

(T)

Multiplexing provides an arrangement for converting a single, higher capacity or bandwidth circuit to several lower capacity or bandwidth circuits.

When a derived channel is itself multiplexed to derive additional channels with a lesser capacity, this is referred to as cascade multiplexing. When cascade multiplexing occurs, a charge for the additional multiplexing function applies. When cascade multiplexing is performed at different hubbing locations, Direct Trunked Transport charges also apply between the hubs.

Multiplexing is only available at wire centers identified in NATIONAL EXCHANGE CARRIER ASSOCIATION, INC. TARIFF NO. 4, WIRE CENTER INFORMATION.

The following multiplexing arrangements are offered for use with Switched Access Service.

- (a) DS3 to DS1 Multiplexing charges specified in Section 17.2.2, following, apply when a High Capacity DS3 Entrance Facility or High Capacity DS3 Direct Trunked Transport is connected with High Capacity DS1 Direct Trunked Transport. The Telephone Company specific rate band assignment for the DS3 to DS1 Multiplexing rate element is specified in the Local Transport (LT) column in Section 17.5.1, following. The DS3 to DS1 multiplexer will convert a 44.736 Mbps channel to 28 DS1 channels using digital time division multiplexing.

---

 Transmittal No. 1403

Issued: November 7, 2013

Effective: November 22, 2013

Director - Access Tariffs  
80 So. Jefferson Road, Whippany, NJ 07981

ACCESS SERVICE

6. Switched Access Service (Cont'd)

6.1 General (Cont'd)

6.1.3 Rate Categories (Cont'd)

(A) Local Transport (Cont'd)

(4) Multiplexing (Cont'd)

(T)

(b) DS1 to Voice Grade Multiplexing charges specified in Section 17.2.2, following, apply when a High Capacity DS1 Entrance Facility or High Capacity DS1 Direct Trunked Transport is connected with Voice Grade Direct Trunked Transport. However, a DS1 to Voice Grade Multiplexing Charge does not apply when a High Capacity DS1 Entrance Facility or High Capacity DS1 Direct Trunked Transport is terminated at an electronic end office and only Switched Access Service is provided over the DS1 facility (i.e., Voice Grade Special Access channels are not derived). The Telephone Company specific rate band assignment for the DS1 to Voice Grade Multiplexing rate element is specified in the Local Transport (LT) column in Section 17.5.1, following. The DS1 to Voice Grade multiplexer will convert a 1.544 Mbps channel to 24 Voice Grade channels.

---

Transmittal No. 1403

Issued: November 7, 2013

Effective: November 22, 2013

Director - Access Tariffs  
80 So. Jefferson Road, Whippany, NJ 07981



ACCESS SERVICE

6. Switched Access Service (Cont'd)

6.1 General (Cont'd)

6.1.3 Rate Categories (Cont'd)

(A) Local Transport (Cont'd)

(5) Add/Drop Multiplexing

(T)

Add/Drop Multiplexing provides a type of multiplexing function in connection with Synchronous Optical Channel Service that allows lower level signals to be added or dropped from a high speed optical carrier channel within a Telephone Company wire center.

The Add/Drop Multiplexing Central Office Port charge specified in Section 17.2.2, following, applies to the interface provided at a Telephone Company wire center for the purpose of adding or dropping lower capacity services from Synchronous Optical Channel Entrance Facilities or Direct Trunked Transport. Central Office Ports are available at the following speeds:

<u>Central Office Port</u>	<u>Speed</u>
OC3	155.52 Mbps
DS3	44.736 Mbps
DS1	1.544 Mbps

The Telephone Company specific rate band assignment for the Add/Drop Multiplexing rate element is specified in the Local Transport (LT) column in Section 17.5.1, following.

Transmittal No. 1403

Issued: November 7, 2013

Effective: November 22, 2013

Director - Access Tariffs  
 80 So. Jefferson Road, Whippany, NJ 07981

ACCESS SERVICE

6. Switched Access Service (Cont'd)

6.1 General (Cont'd)

6.1.3 Rate Categories (Cont'd)

(A) Local Transport (Cont'd)

(5) Add/Drop Multiplexing (Cont'd)

(T)

OC12 service may only be multiplexed to OC3 channels.

When an OC3 channel is derived from an OC12 service and is further multiplexed to obtain DS3 service, a DS3 port charge will apply in addition to the OC3 port charge.

When a DS3 channel is derived from an OC3 service and is further multiplexed to obtain DS1 service, a DS3 to DS1 Multiplexing charge will apply in addition to the DS3 port charge.

When a DS1 channel is directly derived from an OC3 service, a DS1 port charge will apply.

When a DS1 channel is further multiplexed to a lower level signal, a DS1 to Voice Grade Multiplexing charge will also apply.

Add/Drop Multiplexing is only available at wire centers identified in NATIONAL EXCHANGE CARRIER ASSOCIATION, INC. TARIFF F.C.C. NO. 4 WIRE CENTER INFORMATION.

---

Transmittal No. 1403

Issued: November 7, 2013

Effective: November 22, 2013

Director - Access Tariffs  
80 So. Jefferson Road, Whippany, NJ 07981

ACCESS SERVICE

6. Switched Access Service (Cont'd)

6.1 General (Cont'd)

6.1.3 Rate Categories (Cont'd)

(A) Local Transport (Cont'd)

(6) Customer Node

(T)

A Customer Node charge specified in Section 17.2.2, following, applies when the Telephone Company provides terminal equipment at the customer designated premises for termination of a Synchronous Optical Channel Entrance Facility. Such equipment may be used to convert the signal from an optical to electrical format. The Customer Node charge is determined by the level of optical service (i.e., OC3 or OC12) delivered to the premises. Each Customer Node must be configured with one or more Customer Premises Ports.

Customer Premises Port charges specified in Section 17.2.2, following, apply in conjunction with the Customer Node charge. Each Customer Premises Port provides the interface to derive a lower capacity service at the customer premises. The type and quantity of ports is determined by the customer and is based on the type of Customer Node selected and the number of DS1, DS3, STS-1 and/or OC3 channels ordered. Customer Premises Ports are available at the following speeds:

<u>Customer Premises Port</u>	<u>Speed</u>
OC3	155.52 Mbps
STS-1	51.84 Mbps
DS3	44.736 Mbps
DS1	1.544 Mbps

The Telephone Company specific rate band assignment for the Customer Node and Customer Premises Port rate elements is specified in the Local Transport (LT) column in Section 17.5.1, following.

Transmittal No. 1403

Issued: November 7, 2013

Effective: November 22, 2013

Director - Access Tariffs  
 80 So. Jefferson Road, Whippany, NJ 07981

## ACCESS SERVICE

6. Switched Access Service (Cont'd)6.1 General (Cont'd)6.1.3 Rate Categories (Cont'd)(A) Local Transport (Cont'd)(7) Interface Groups

(T)

Ten Interface Groups are provided for terminating the Entrance Facility at the customer's designated premises. Technical specifications concerning the available interface groups are set forth in Section 15.1, following.

(8) Nonchargeable Optional Features

(T)

Where transmission facilities permit, the individual transmission path between the customer's designated premises and the first point of switching, may at the option of the customer, be provided with the following optional features as set forth and described in Section 15.1.1(E), following.

- Supervisory Signaling
- Customer Specified Entry Switch Receive Level
- Customer Specification of Local Transport Termination
- 64 Clear Channel Capability

In addition to the above, Shared SONET Interoffice Ring Transport (SSRIT) is available as a nonchargeable optional feature with High Capacity DS3 or Synchronous Optical Channel Local Transport service from wire centers identified in the NATIONAL EXCHANGE CARRIER ASSOCIATION, INC. TARIFF F.C.C. NO. 4, WIRE CENTER INFORMATION. The SSRIT feature is set forth and described in Sections 7.10.3(E) and 7.11.3(C), following.

When a customer subscribes to Common Channel Signaling (SS7) Network Connection Service (CCSNC Service), the following optional features are made available and are described in Section 6.10.1, following.

- Signaling System 7 (SS7) Signaling
- Calling Party Number
- Carrier Selection Parameter
- Charge Number Parameter
- Carrier Identification Parameter

Transmittal No. 1403

Issued: November 7, 2013

Effective: November 22, 2013

Director - Access Tariffs  
80 So. Jefferson Road, Whippany, NJ 07981

ACCESS SERVICE

6. Switched Access Service (Cont'd)

6.1 General (Cont'd)

6.1.3 Rate Categories (Cont'd)

(A) Local Transport (Cont'd)

(9) Chargeable Optional Features

Common Channel Signaling, Signaling System 7 (CCS/SS7) Network Connection (CCSNC) Service provides a signaling path between a customer's designated Signaling Point of Interface (SPOI) and a Telephone Company's Signaling Transfer Point (STP). CCSNC is provided as set forth in Section 6.10.3, following.

Toll Free Database Access Service is provided to all customers in conjunction with FGC and FGD switched access service. A Basic or Vertical Feature Query charge, as set forth in Section 17.2.2 (B), following, is assessed for each completed query returned from the toll free database whether or not the actual call is delivered to the customer. The query is considered completed when the appropriate call routing information is returned to the Service Switching Point (SSP) that launched the query and the results are transmitted to the next company in the call path. If the originating company transmits the results of the query, it will assess the query charge per call. However, when the originating company is unable to do so, the next company in the call path that is able to launch and transmit the results of the query will assess the query charge. Only one query charge per call may be assessed.

(T)  
 (T)  
 (C)  
 (C)

Certain material formerly found on this page now appears on 1st Revised Page 6-12.1.

Transmittal No. 1635

Issued: June 16, 2021

Effective: July 1, 2021

Senior Director - Access Tariffs & Costs  
 60 Columbia Road, Bldg. A - 2nd Fl., Morristown, NJ 07960

## ACCESS SERVICE

6. Switched Access Service (Cont'd)6.1 General (Cont'd)6.1.3 Rate Categories (Cont'd)(A) Local Transport (Cont'd)(9) Chargeable Optional Features (Cont'd)

The Basic Query provides the identification of the customer to whom the call will be delivered and includes area of service routing which allows routing of 800 series calls by telephone companies to different interexchange carriers based on the Local Access Transport Area (LATA) in which the call originates. The Vertical Feature Query provides this same customer identification function in addition to vertical features which may include: (1) call validation (ensuring that calls originate from subscribed service areas); (2) POTS translation of 800 series numbers (which is generally necessary for the routing of 800 series calls); (3) alternate POTS translation (which allows subscribers to vary the routing of 800 series calls based on factors such as time of day, place of origination of the call, etc.); and (4) multiple carrier routing (which allows subscribers to route to different carriers based on factors similar to those in (3)).

(M)

(M)

When ordered for use with ESALT Direct Trunked Facility provided entirely within the Telephone Company's operating territory, the ESALT Real Time Class of Service/Quality of Service (RT CoS/QoS) option provides service performance commitments on transmissions using the Telephone Company's Ethernet local transport network. ESALT RT CoS/QoS is provided as set forth in Section 6.10.3(E), following.

When ordered for use with ESALT Entrance Facility, the ESALT Entrance Facility Protection (ESALT EFP) option provides backup protection using the Telephone Company's Ethernet local transport network. ESALT EFP is provided as set forth in Section 6.10.3(F), following.

Certain material currently found on this page previously appeared on 10th Revised Page 6-12.

Transmittal No. 1635

Issued: June 16, 2021

Effective: July 1, 2021

Senior Director - Access Tariffs & Costs  
60 Columbia Road, Bldg. A - 2nd Fl., Morristown, NJ 07960

ACCESS SERVICE

6. Switched Access Service (Cont'd)

6.1 General (Cont'd)

6.1.3 Rate Categories (Cont'd)

(A) Local Transport (Cont'd)

(B) End Office

The End Office rate category establishes the charges related to the local end office switching and end user termination functions necessary to complete the transmission of Switched Access communications to and from the end users served by the local end office. The End Office rate category includes the Local Switching and Information Surcharge rate elements. Directory Assistance Service is set forth in Section 9, following.

(1) Local Switching

The Local Switching rate element establishes the charges related to the use of end office switching equipment, the terminations in the end office of end user lines, the terminations of calls at Telephone Company Intercept Operators or recordings, the STP costs, and the SS7 signaling function between the end office and the Signaling Transfer Point.

Certain material previously found on this page now appears on Original Page 6-12.1.

Transmittal No. 1403

Issued: November 7, 2013

Effective: November 22, 2013

Director - Access Tariffs  
80 So. Jefferson Road, Whippany, NJ 07981

ACCESS SERVICE

6. Switched Access Service (Cont'd)

6.1 General (Cont'd)

6.1.3 Rate Categories (Cont'd)

(B) End Office (Cont'd)

(1) Local Switching (Cont'd)

Local Switching does not apply to Feature Groups B and D Switched Access Services associated with Wireless Switching Center (WSCs) directly interconnected to a Telephone Company access tandem office.

Where end offices are appropriately equipped, international dialing may be provided as a capability associated with Local Switching which provides local dial switching for Feature Groups C and D. International dialing provides the capability of switching international calls with service prefix and address codes having more digits than are capable of being switched through a standard FGC or FGD equipped end office.

Rates for Local Switching are set forth in Section 17.2.3(A), following. The application of these rates with respect to individual Feature Groups is as set forth in Section 6.4.1(C), following.

(C)  
(C)

The Telephone Company specific rate band assignment for the Local Switching rate element is specified in Section 17.5.1, following.

There are four types of functions included in the Local Switching rate element: Common Switching, Transport Termination, Line Termination and Intercept. These are described in (a) through (d) following.

Transmittal No. 1694

Issued: June 16, 2023

Effective: July 1, 2023



ACCESS SERVICE

6. Switched Access Service (Cont'd)

6.1 General (Cont'd)

6.1.3 Rate Categories (Cont'd)

(B) End Office (Cont'd)

(1) Local Switching (Cont'd)

(a) Common Switching

Common Switching provides the local end office switching functions associated with the various access (i.e., Feature Group) switching arrangements. The Common Switching arrangements provided for the various Feature Group arrangements are described in 6.5 through 6.9 following.

Included as part of Common Switching are various nonchargeable optional features which the customer can order to meet the customer's specific communications requirements. These optional features are described in 6.10.1 following.

(b) Transport Termination

Transport Termination functions provide for the line or trunk side arrangements which terminate the Local Transport facilities. Included as part of these functions are various nonchargeable optional termination arrangements. These optional terminating arrangements are described in 6.10.2 following.

The number of Transport Terminations provided will be determined by the Telephone Company as set forth in 6.2.5 following.

(x) Issued to reflect new corporate address.

Transmittal No. 855

Issued: February 23, 2000

Effective: March 9, 2000

## ACCESS SERVICE

6. Switched Access Service (Cont'd)6.1 General (Cont'd)6.1.3 Rate Categories (Cont'd)(B) End Office (Cont'd)(1) Local Switching (Cont'd)(c) Line Termination

Line Termination provides for the terminations of end user lines in the local end office. There are two types of Line Terminations, i.e., Common Line Terminations and Special Access Service Terminations utilized in the provision of WATS or WATS-type services at Telephone Company designated WATS Serving Offices.

The above Special Access Service Terminations are differentiated by line side vs. trunk side terminations. In addition, there are various types of originating and terminating line side terminations depending on the type of signaling associated with the Special Access Service. Line side terminations are available with either dial pulse or dual tone multifrequency address signaling.

(x) Issued to reflect new corporate address.

Transmittal No. 855

Issued: February 23, 2000

Effective: March 9, 2000

Director - Access Tariffs  
80 So. Jefferson Road, Whippany, NJ 07981

## ACCESS SERVICE

6. Switched Access Service (Cont'd)6.1 General (Cont'd)6.1.3 Rate Categories (Cont'd)(B) End Office (Cont'd)(1) Local Switching (Cont'd)(d) Intercept

The Intercept function provides for the termination of a call at a Telephone Company Intercept operator or recording. The operator or recording tells a caller why a call, as dialed, could not be completed, and if possible, provides the correct number.

(2) Information Surcharge

Information Surcharge rates are assessed to a customer based on the total number of access minutes. Information Surcharge rates are as set forth in 17.2.3(B) following. The application of these rates with respect to individual Feature Groups is as set forth in 6.4.1(C) following.

(C)  
(C)

The Information Surcharge does not apply to Feature Groups B and D Switched Access Services associated with Wireless Switching Centers (WSCs) directly interconnected to a Telephone Company access tandem office.

The number of end office switching transmission paths will be determined as set forth in 6.2.5 following.

Transmittal No. 1694

Issued: June 16, 2023

Effective: July 1, 2023

Senior Director - Access Tariff Cost Development  
60 Columbia Road, Bldg. A - 2nd Fl., Morristown, NJ 07960

## ACCESS SERVICE

6. Switched Access Service (Cont'd)6.1 General (Cont'd)6.1.3 Rate Categories (Cont'd)(C) Chargeable Optional Features

Where facilities permit, the Telephone Company will, at the option of the customer, provide the following chargeable optional features.

(1) Interim NXX Translation

The Interim NXX Translation rate element provides for customer identification of non-data base services when calls are directed by end users in the 1+SAC+NXX-XXXX (e.g., 1+900+NXX-XXXX) format. The NXX codes are assigned to specific customers in conformance with the North American Numbering Plan (NANP). NXX code assignment(s) will be made by the NANP Coordinator. The Telephone Company will use the NXX code to identify the customer to whose point of termination the traffic is to be delivered, (i.e., at appropriately equipped electronic end offices, access tandems or through contracted arrangements with other parties.) It is then the responsibility of the customer to do any further translation the customer deems necessary to route the call. Customer assigned NXX codes which have not been ordered will be blocked.

(x) Issued to reflect new corporate address.

Transmittal No. 855

Issued: February 23, 2000

Effective: March 9, 2000

Director - Access Tariffs  
80 So. Jefferson Road, Whippany, NJ 07981

## ACCESS SERVICE

APPROVED

6. Switched Access Service (Cont'd)6.1 General (Cont'd)6.1.3 Rate Categories (Cont'd)(C) Chargeable Optional Features (Cont'd)(1) Interim NXX Translation (Cont'd)

A nonrecurring charge, as set forth in 17.2.1 following, is associated with this optional feature. This nonrecurring charge is assessed by the Telephone Company on a per order, per LATA or Market Area basis and is applied in lieu of the Access Order Charge specified in 17.4.1(A) following. The nonrecurring charge is assessed only by the Telephone Company that provides the final translation function. A Telephone Company is said to have provided the final Interim NXX Translation when its translation identifies the customer's traffic and this traffic is then delivered to the customer's point of termination without any further translation. The description and application of this charge with respect to Feature Group C and Feature Group D is as set forth in 6.4.1(B) (2) and 6.4.1(C) (2) following.

(2) Operator Transfer Services

Operator Transfer Service may be provided with Feature Group C or Feature Group D Switched Access Service at Telephone Company designated Operator Services location. Operator Transfer Service is an originating service. The rate is assessed per 0- call transferred to a customer's operator. An 0- call is considered transferred when the Telephone Company Operator activates the switch transferring the call to the designated customer and the customer acknowledges receipt.

In addition to the Operator Transfer Service charge described above and in 6.10.3(B) following, Feature Group C or Feature Group D Switched Access rates and charges as set forth in 6.4.1(B) (1) and 6.4.1(C) following will apply per minute of use for Operator Transfer Service.

(C)  
(C)

Transmittal No. 988

Issued: June 16, 2003

Effective:

8 / 13 / 03

Director - Access Tariffs  
80 So. Jefferson Road, Whippany, NJ 07981

## ACCESS SERVICE

6. Switched Access Service (Cont'd)6.1 General (Cont'd)6.1.3 Rate Categories (Cont'd)(C) Chargeable Optional Features (Cont'd)(2) Operator Transfer Services (Cont'd)

Operator Transfer Service charges, provided for in this tariff, are applied only to those calls actually transferred by the Telephone Company to the customer's operator.

(3) Toll Free Database Access Service (T)

Toll Free Database Access Service is provided to all customers in conjunction with FGC and FGD switched access service. When a 1+800 series+NXX-XXXX call is originated by an end user, the Telephone Company will utilize the Signaling System 7 (SS7) network to query the toll free database to identify the customer to whom the call will be delivered and provide vertical features based on the dialed ten digits. The call will then be routed to the identified customer over FGC or FGD switched access. The 800 series includes the following service access codes: 800, 888, 877, 866, 855, 844, 833 and 822. (T)

---

 Transmittal No. 1635

Issued: June 16, 2021

Effective: July 1, 2021

Senior Director - Access Tariffs & Costs  
60 Columbia Road, Bldg. A - 2nd Fl., Morristown, NJ 07960

ACCESS SERVICE

6. Switched Access Service (Cont'd)

6.1 General (Cont'd)

6.1.3 Rate Categories (Cont'd)

(C) Chargeable Optional Features (Cont'd)

(3) Toll Free Database Access Service (Cont'd) (T)

A Basic or Vertical Feature Query charge, as set forth in 17.2.2(B) following, is assessed for each completed query returned from the database identifying the customer to whom the call will be delivered whether or not the actual call is delivered to the customer. The query is considered completed when the appropriate call routing information is returned to the Service Switching Point (SSP) that launched the query and the results are transmitted to the next company in the call path. If the originating company transmits the results of the query, it will assess the query charge per call. However, when the originating company is unable to do so, the next company in the call path that is able to launch and transmit the results of the query will assess the query charge. Only one query charge per call may be assessed. (T)

The Basic Query provides the identification of the customer to whom the call will be delivered and includes area of service routing which allows routing of 800 series calls by telephone companies to different interexchange carriers based on the Local Access Transport Area (LATA) in which the call originates. The Vertical Feature Query provides the same customer identification as the basic query and vertical features which may include: (1) call validation, (ensuring that calls originate from subscribed service areas); (2) POTS translation of 800 series numbers; (3) alternate POTS translation (which allows subscribers to vary the routing of 800 series calls based on factors such as time of day, place or origination of the call, etc.); and (4) multiple carrier routing (which allows subscribers to route to different carriers based on factors similar to those in (3)). (C)

The description and application of this charge with respect to Feature Group C or Feature Group D is as set forth in 6.4.1(C) (2) and 6.4.1(C) (8) following.

Transmittal No. 1635

Issued: June 16, 2021

Effective: July 1, 2021

ACCESS SERVICE

6. Switched Access Service (Cont'd)

(D)

(D)

6.1.4 Special Facilities Routing

Any customer may request that the facilities used to provide Switched Access Service be specially routed. The regulations for Special Facilities Routing (i.e., Avoidance, Diversity and Cable-Only) are set forth in Section 11, following.

(T)

6.1.5 Design Layout Report

At the request of the customer, the Telephone Company will provide to the customer the makeup of the facilities and services provided from the customer's premises to the first point of switching. This information will be provided in the form of a Design Layout Report. The Design Layout Report will be provided to the customer at no charge, and will be reissued or updated whenever these facilities are materially changed.

6.2 Undertaking of the Telephone Company

In addition to the obligations of the Telephone Company set forth in Section 2, preceding, the Telephone Company has certain other obligations concerning only the provision of Switched Access Service. These obligations are as follows:

(T)

6.2.1 Network Management

The Telephone Company will administer its network to insure the provision of acceptable service levels to all telecommunications users of the Telephone Company's network services. Generally, service levels are considered acceptable only when both end users and

---

Transmittal No. 1403

Issued: November 7, 2013

Effective: November 22, 2013

Director - Access Tariffs  
80 So. Jefferson Road, Whippany, NJ 07981



## ACCESS SERVICE

6. Switched Access Service (Cont'd)6.2 Undertaking of the Telephone Company (Cont'd)6.2.1 Network Management (Cont'd)

customers are able to establish connections with little or no delay encountered within the Telephone Company network. The Telephone Company maintains the right to apply protective controls, i.e., those actions, such as call gapping, which selectively cancel the completion of traffic, over any traffic carried over its network, including that associated with a customer's Switched Access Service. Generally, such protective measures would only be taken as a result of occurrences such as failure or overload of Telephone Company or customer facilities, natural disasters, mass calling or national security demands. In the event that the protective controls applied by the Telephone Company result in the complete loss of service by the customer, the customer will be granted a Credit Allowance for Service Interruption as set forth in 2.4.4(B) (3) preceding.

6.2.2 Transmission Specifications

Each Switched Access Service transmission path is provided with standard transmission specifications. There are three different standard specifications (Types A, B and C). The standard for a particular transmission path is dependent on the Feature Group, the Interface Group and whether the service is directly routed or via an access tandem. The available transmission specifications are set forth in 15.1.2 following. Data Transmission Parameters are also provided with each Switched Access Service transmission path. The Telephone Company will, upon notification by the customer that the data parameters set forth in 15.1.3 following are not being met, conduct tests independently or in cooperation with the customer, and take any necessary action to insure that the data parameters are met.

The Telephone Company will maintain existing transmission specifications on functioning service configurations installed prior to May 25, 1984, except that service configurations having performance specifications exceeding the standards set forth in 15.1.2 following will be maintained at the performance levels specified.

(x) Issued to reflect new corporate address.

Transmittal No. 855

Issued: February 23, 2000

Effective: March 9, 2000

Director - Access Tariffs  
80 So. Jefferson Road, Whippany, NJ 07981

## ACCESS SERVICE

6. Switched Access Service (Cont'd)6.2 Undertaking of the Telephone Company (Cont'd)6.2.2 Transmission Specifications (Cont'd)

The transmission specifications concerning Switched Access Service are limits which, when exceeded, may require the immediate corrective action of the Telephone Company. The transmission specifications are set forth in 15.1.2 following. Acceptance limits are set forth in Technical Reference GR-334-CORE. This Technical Reference also provides the basis for determining Switched Access Service maintenance limits.

Feature Group C and Feature Group D trunks equipped for Operator Transfer Service are subject to Feature Group C and Feature Group D transmission specifications, respectively, unless otherwise specified.

6.2.3 Provision of Service Performance Data

Subject to availability, end-to-end service performance data available to the Telephone Company through its own service evaluation routines, may also be made available to the customer based on previously arranged intervals and format. These data provide information on overall end-to-end call completion and non-completion performance, e.g., customer equipment blockage, failure results and transmission performance. These data do not include service performance data which are provided under other tariff sections, e.g., testing service results. If data are to be provided in other than paper format, the charges for such exchange will be determined on an individual case basis.

6.2.4 Testing(A) Acceptance Testing

At no additional charge the Telephone Company will, at the customer's request, cooperatively test at the time of installation, the following parameters: loss, C-notched noise, C-message noise, 3-tone slope, d.c. continuity and operational signaling. When the Local Transport is provided with Interface Groups 2 through 10, and the Transport Termination is two-wire (i.e., there is a four-wire to two-wire conversion in Local Transport), balance parameters (equal level echo path loss) may also be tested.

(x) Issued to reflect new corporate address.

Transmittal No. 855

Issued: February 23, 2000

Effective: March 9, 2000

Director - Access Tariffs  
80 So. Jefferson Road, Whippany, NJ 07981

## ACCESS SERVICE

6. Switched Access Service (Cont'd)6.2 Undertaking of the Telephone Company (Cont'd)6.2.4 Testing (Cont'd)(B) Routine Testing

At no additional charge, the Telephone Company will, at the customer's request, test after installation on an automatic or manual basis, 1004 Hz loss, C-message noise and Balance (Improved Return loss).

In the case of automatic testing, the customer shall provide remote office test lines and 105 test lines with associated responders or their functional equivalent.

The frequency of these tests will be that which is mutually agreed upon by the customer and the Telephone Company, but shall consist of not less than quarterly 1004 Hz Loss and C-message noise tests and an annual Balance test. Trunk test failures requiring customer participation for trouble resolution will be provided to the customer on an as-occurs basis.

Additional tests may be ordered as set forth in 13.3.1 following. Charges for these additional tests are set forth in 17.4.4 following.

(x) Issued to reflect new corporate address.

Transmittal No. 855

Issued: February 23, 2000

Effective: March 9, 2000

Director - Access Tariffs  
80 So. Jefferson Road, Whippany, NJ 07981

## ACCESS SERVICE

6. Switched Access Service (Cont'd)6.2 Undertaking of the Telephone Company (Cont'd)6.2.5 Determination of Number of Transmission Paths

For Feature Groups A and B, which are ordered on a per line or per trunk basis respectively, and Feature Groups C and D when ordered on a per trunk basis the customer specifies the type of transport facilities and the number of channels in the order for service.

For Tandem Switched Transport, the Telephone Company will determine the number of Switched Access Service transmission paths to be provided for the Switched Access Feature Group C and D busy hour minutes of capacity ordered. The number of transmission paths will be developed using the total busy hour minutes of capacity by type (as described in Section 6.1.1(B), preceding) for the end offices for each Feature Group ordered from a customer's designated premises or from an IPG SWC when the customer uses Feature Group D in conjunction with IPG as described in Section 16.4, following. The total busy hour minutes of capacity by type (e.g., originating, terminating, IDDD, Operator) for the end office will be converted to transmission paths using standard Telephone Company traffic engineering methods. The number of transmission paths provided shall be the number required based on (1) the use of access tandem switches and end office switches, (2) the use of the end office switches only, or (3) the use of the tandem switches only. (C)

---

Transmittal No. 1309

Issued: April 15, 2011

Effective:

JUN 06 2011

Director - Access Tariffs  
80 So. Jefferson Road, Whippany, NJ 07981

ACCESS SERVICE

6. Switched Access Service (Cont'd)

6.2 Undertaking of the Telephone Company (Cont'd)

6.2.6 Trunk Group Measurement Reports

Subject to availability, the Telephone Company will make available trunk group data in the form of usage in CCS, peg count and overflow, to the customer based on previously agreed to intervals.

(x) Issued to reflect new corporate address.

Transmittal No. 855

---

Issued: February 23, 2000

Effective: March 9, 2000

Director - Access Tariffs  
80 So. Jefferson Road, Whippany, NJ 07981

## ACCESS SERVICE

6. Switched Access Service (Cont'd)6.3 Obligations of the Customer

In addition to the obligations of the customer set forth in Section 2. preceding, the customer has certain specific obligations pertaining to the use of Switched Access Service. These obligations are as follows:

6.3.1 Report Requirements

Customers are responsible for providing the following reports to the Telephone Company, when applicable.

(A) Jurisdictional Reports

When a customer orders Switched Access Service for both interstate and intrastate use, the customer is responsible for providing reports as set forth in 2.3.11 preceding. Charges will be apportioned in accordance with those reports. The method to be used for determining the interstate charges is set forth in 2.3.12 preceding.

(B) Code Screening Reports

When a customer orders service class routing, trunk access limitation or call gapping arrangements, it must report the number of trunks and/or the appropriate codes to be instituted in each end office or access tandem switch, for each of the arrangements ordered.

(x) Issued to reflect new corporate address.

Transmittal No. 855

Issued: February 23, 2000

Effective: March 9, 2000

Director - Access Tariffs  
80 So. Jefferson Road, Whippany, NJ 07981

## ACCESS SERVICE

6. Switched Access Service (Cont'd)6.3 Obligations of the Customer (Cont'd)6.3.2 Trunk Group Measurement Reports

With the agreement of the customer, trunk group data in the form of usage in CCS, peg count and overflow for its end of all access trunk groups, where technologically feasible, will be made available to the Telephone Company. These data will be used to monitor trunk group utilization and service performance and will be based on previously arranged intervals and format.

6.3.3 Supervisory Signaling

The customer's facilities shall provide the necessary on-hook, off-hook, answer and disconnect supervision.

6.3.4 Short Duration Mass Calling Requirements

When a customer offers service for which a substantial call volume is expected during a short period of time (e.g., 900 service media stimulated events), the customer must notify the Telephone Company at least 48 hours in advance of each peak period. Notification should include the nature, time, duration, and frequency of the event, an estimated call volume, and the telephone number(s) to be used.

On the basis of the information provided, the telephone Company may invoke network management controls, (e.g., call gapping and code blocking) to reduce the probability of excessive network congestion. The Telephone Company will work cooperatively with the customer to determine the appropriate level of such control.

(x) Issued to reflect new corporate address.

Transmittal No. 855

Issued: February 23, 2000

Effective: March 9, 2000

Director - Access Tariffs  
80 So. Jefferson Road, Whippany, NJ 07981

ACCESS SERVICE

6. Switched Access Service (Cont'd)

6.3 Obligations of the Customer (Cont'd)

6.3.5 Call Signaling

Depending on the signaling system used by the customer in its network, the customer's facilities shall transmit the following call signaling information to the Telephone Company on traffic the customer's end users originate which is handed off for termination on the Telephone Company's network.

(A) Signaling System 7 (SS7) Signaling

When the customer uses SS7 signaling, it will transmit the Calling Party Number (CPN) or, if different from the CPN, the Charge Number (CN) information in the SS7 signaling stream.

(B) Multi-Frequency (MF) Signaling

When the customer uses MF signaling, it will transmit the number of the calling party or, if different from the number of the calling party, the Charge Number (CN) information in the MF Automatic Number Identification (ANI) field.

(C) Internet Protocol (IP) Signaling

When the customer uses IP signaling, it will transmit the telephone number of the calling party or, if different from the telephone number, the billing number of the calling party.

When the customer uses IP signaling in conjunction with ESALT, it will transmit call signaling data that must either: 1) conform to an active 10-digit North American Numbering Plan or directory number which is associated with the geographic location of the originating calling party (i.e., Calling Party Number and/or Automatic Number Identification) or 2) represent IP equivalent call signaling that is mutually agreed upon by the customer and Telephone Company at the time the customer places its order for ESALT.

(N)  
|  
(N)

Transmittal No. 1403

Issued: November 7, 2013

Effective: November 22, 2013

Director - Access Tariffs  
80 So. Jefferson Road, Whippany, NJ 07981



## ACCESS SERVICE

6. Switched Access Service (Cont'd)6.4 Rate Regulations

This section contains the specific regulations governing the rates and charges that apply for Switched Access Service.

6.4.1 Description and Application of Rates and Charges

There are two types of rates and charges that apply to Switched Access Service; recurring (usage and flat rates) and nonrecurring charges. These rates and charges are applied differently to the various rate elements as set forth in (C) following.

(A) Recurring Rates

- (1) Usage Rates for Switched Access Service are rates that apply on a per access minute or a per call basis. Access minute charges and per call charges are accumulated over a monthly period.
- (2) Flat Rates for Switched Access Service are rates that apply on a per month per rate element basis.

(B) Nonrecurring Charges

Nonrecurring charges are one-time charges that apply for a specific work activity (i.e., installation or change to an existing service). The types of nonrecurring charges that apply for Switched Access Service are: installation of service, Interim NXX Translation optional feature, and service rearrangements. These charges, with the exception of the Interim NXX Translation optional feature, are in addition to the Access Order Charge as specified in 17.4.1(A) following.

(1) Installation of Service

(x) Issued to reflect new corporate address.

Transmittal No. 855

Issued: February 23, 2000

Effective: March 9, 2000

Director - Access Tariffs  
80 So. Jefferson Road, Whippany, NJ 07981

ACCESS SERVICE

6. Switched Access Service (Cont'd)

6.4 Rate Regulations (Cont'd)

6.4.1 Description and Application of Rates and Charges  
(Cont'd)

(B) Nonrecurring Charges (Cont'd)

(1) Installation of Service (Cont'd)

For Entrance Facilities, a Local Transport nonrecurring installation charge, as set forth in Section 17.2.1(A), following, will be applied at the serving wire center for each Entrance Facility installed. (T)

Except as specified below for ESALT, when Direct Trunked Transport is ordered to the end office, a Local Transport nonrecurring trunk activation charge, as set forth in Section 17.2.1 (E), following, will be applied at the end office on a per order basis for each group of 24 Direct Trunked Transport trunks or fraction thereof that is activated at the end office. (C)  
(C)  
(T)

Except as specified below for ESALT, when Direct Trunked Transport is ordered to the access tandem, a Local Transport nonrecurring trunk activation charge, as set forth in Section 17.2.1(E), following, will be applied at the access tandem on a per order basis for each group of 24 Direct Trunked Transport trunks or fraction thereof that is activated at the access tandem. (C)  
(C)  
(T)

Transmittal No. 1403

Issued: November 7, 2013

Effective: November 22, 2013

Director - Access Tariffs  
80 So. Jefferson Road, Whippany, NJ 07981

ACCESS SERVICE

6. Switched Access Service (Cont'd)

6.4 Rate Regulations (Cont'd)

6.4.1 Description and Application of Rates and Charges  
(Cont'd)

(B) Nonrecurring Charges (Cont'd)

(1) Installation of Service (Cont'd)

A maximum of 24 trunks can be activated on a DS1 facility and a maximum of 672 trunks can be activated on a DS3 facility.

For example, if a customer orders a DS1 Entrance Facility and requests activation of 18 of the available circuits, the customer will be charged one Local Transport High Capacity DS1 Installation nonrecurring charge at the serving wire center and one Direct Trunked Transport Activation nonrecurring charge at the end office. If at a later date the customer requests the activation of three more circuits, the customer will then be charged an additional Direct Trunked Transport Activation nonrecurring charge. These charges are in addition to the Access Order Charge as specified in Section 17.4.1(A), following.

(T)

An ESALT Direct Trunked Termination nonrecurring charge, as specified in Section 17.2.1(F), following, will be applied per ESALT Direct Trunked Termination installed.

(N)

(N)

Certain material previously found on this page now appears on Original Page 6-28.2.

Transmittal No. 1403

Issued: November 7, 2013

Effective: November 22, 2013

Director - Access Tariffs  
80 So. Jefferson Road, Whippany, NJ 07981

ACCESS SERVICE

(N)

6. Switched Access Service (Cont'd)

6.4 Rate Regulations (Cont'd)

6.4.1 Description and Application of Rates and Charges  
(Cont'd)

(B) Nonrecurring Charges (Cont'd)

(N)

(2) Interim NXX Translation Optional Feature

(M)

This nonrecurring charge applies to the initial order for the installation of the Interim NXX Translation optional feature with Feature Group C or Feature Group D Switched Access Service and for each subsequent order received to add or change NXX translation codes. This charge, if applicable, applies whether this optional feature is installed coincident with or at any time subsequent to the installation of Switched Access Services. This charge is applied by the Telephone Company per order, per LATA or Market Area. When it is necessary for multiple telephone companies to provide the translation function, the nonrecurring charge is assessed only by the Telephone Company that provides the final translation function which identifies the customer's traffic and this traffic is then delivered to the customer's point of termination without any further translation.

(M)

Certain material currently found on this page previously appeared on 1st Revised Page 6-28.1.

Transmittal No. 1403

Issued: November 7, 2013

Effective: November 22, 2013

Director - Access Tariffs  
80 So. Jefferson Road, Whippany, NJ 07981

## ACCESS SERVICE

6. Switched Access Service (Cont'd)6.4 Rate Regulations (Cont'd)6.4.1 Description and Application of Rates and Charges (Cont'd)(B) Nonrecurring Charges (Cont'd)(3) Service Rearrangements

All changes to existing services other than changes involving administrative activities and the off-hook supervisory signaling of FGA Access Services, will be treated as a discontinuance of the existing service and an installation of a new service. The nonrecurring charge described in (1) preceding will apply for this work activity. Moves that change the physical location of the point of termination are described and charged for as set forth in 6.4.4 following.

- If, due to technical limitations of the Telephone Company, a customer could not combine its Interim NXX traffic with its other trunk side Switched Access Services, no charge shall apply to combine these trunk groups when it becomes technically possible.

(x) Issued to reflect new corporate address.

Transmittal No. 855

Issued: February 23, 2000

Effective: March 9, 2000

Director - Access Tariffs  
80 So. Jefferson Road, Whippany, NJ 07981

## ACCESS SERVICE

6. Switched Access Service (Cont'd)6.4 Rate Regulations (Cont'd)6.4.1 Description and Application of Rates and Charges (Cont'd)(B) Nonrecurring Charges (Cont'd)(3) Service Rearrangements (Cont'd)

Administrative changes will be made without charge(s) to the customer. Administrative changes are as follows:

- Change of customer name,
- Change of customer or customer's end user premises address when the change of address is not a result of a physical relocation of equipment,
- Change in billing data (name, address, or contact name or telephone number),
- Change of agency authorization,
- Change of customer circuit identification,
- Change of billing account number,
- Change of customer test line number,
- Change of customer or customer's end user contact name or telephone number, and
- Change of jurisdiction.

Other changes made without charge to the customer are as follows:

- Changes and additions to existing Switched Access Services which are necessary due to Telephone Company initiated network reconfigurations, and required to provide the same grade of service to the customer that existed prior to the reconfiguration. Charges will apply to those changes and additions which are in excess of those required to provide the same grade of service and/or capacity. Grade of service will be as determined by industry standard engineering tables.

(x) Issued to reflect new corporate address.

Transmittal No. 855

Issued: February 23, 2000

Effective: March 9, 2000

Director - Access Tariffs  
80 So. Jefferson Road, Whippany, NJ 07981

ACCESS SERVICE

6. Switched Access Service (Cont'd)

6.4 Rate Regulations (Cont'd)

6.4.1 Description and Application of Rates and  
(Cont'd)

(B) Nonrecurring Charges (Cont'd)

(3) Service Rearrangements (Cont'd)

This page intentionally left blank.

(x) Issued to reflect new corporate address.

Transmittal No. 855

Issued: February 23, 2000

Effective: March 9, 2000

Director - Access Tariffs  
80 So. Jefferson Road, Whippany, NJ 07981

ACCESS SERVICE

6. Switched Access Service (Cont'd)

6.4 Rate Regulations (Cont'd)

6.4.1 Description and Application of Rates and Charges  
(Cont'd)

(B) Nonrecurring Charges (Cont'd)

(3) Service Rearrangements (Cont'd)

This page intentionally left blank.

(x) Issued to reflect new corporate address.

Transmittal No. 855

Issued: February 23, 2000

Effective: March 9, 2000

Director - Access Tariffs  
80 So. Jefferson Road, Whippany, NJ 07981



## ACCESS SERVICE

6. Switched Access Service (Cont'd)6.4 Rate Regulations (Cont'd)6.4.1 Description and Application of Rates and Charges  
(Cont'd)(B) Nonrecurring Charges (Cont'd)(3) Service Rearrangements (Cont'd)

Changes to the point in time when the off-hook supervisory signal is provided in the originating call sequence i.e., when the off-hook supervisory signal is changed from being provided by the customer's equipment before the called party answers to being forwarded by the customer's equipment when the called party answers or vice versa, are subject to the Access Order Charge as set forth in 17.4.1(A) following.

For additions, changes or modifications to an optional feature which has a separate nonrecurring charge, that nonrecurring charge will apply.

For additions, changes, or modifications to optional features that do not have their own separate nonrecurring charges, an Access Order Charge as set forth in 17.4.1(A) following will apply (with the exception of the addition of 64 Clear Channel Capability to an existing service). When an optional feature is not required on each transmission path, but rather for an entire transmission path group, an end office or an access tandem switch, only one such charge will apply (i.e., it will not apply per transmission path).

When the 64 Clear Channel Capability optional feature is installed on an existing facility, the addition will be treated as a discontinuance and start of service and all associated non-recurring charges will apply.

For conversion of FGC and FGD trunks from multifrequency address signaling to SS7 signaling or from SS7 signaling to multifrequency address signaling, nonrecurring charges will apply as set forth in 17.2.1(D).

(x) Issued to reflect new corporate address.

Transmittal No. 855

Issued: February 23, 2000

Effective: March 9, 2000

Director - Access Tariffs  
80 So. Jefferson Road, Whippany, NJ 07981

## ACCESS SERVICE

6. Switched Access Service (Cont'd)6.4 Rate Regulations (Cont'd)6.4.1 Description and Application of Rates and Charges  
(Cont'd)(B) Nonrecurring Charges (Cont'd)(C) Application of Rates

Rates are applied either as premium or non-premium rates.

The application of these rates is dependent upon the Feature Group, type of Entrance Facility, type of transport (e.g., Direct Trunked Transport, Tandem Switched Transport, type of Multiplexing) and the availability of equal access capabilities in the end office to which the service is provided.

The following rules provide the basis for applying the rates and charges:

(1) Premium Rates

Premium rates apply to all FGC access minutes when the service is provided to customers which furnish interstate MTS/WATS, to all access minutes that originate or terminate at end offices equipped with equal access (i.e., FGD) capabilities, and to Directory Transport Service. Premium rates also apply to FGB and FGD access minutes that originate or terminate at a Wireless Switching Center (WSC) that is directly connected to a Telephone Company access tandem office. In addition, premium rates apply to FGA and FGB access minutes when utilized in the provision of MTS/WATS service.

(x) Issued to reflect new corporate address.

Transmittal No. 855

Issued: February 23, 2000

Effective: March 9, 2000

Director - Access Tariffs  
80 So. Jefferson Road, Whippany, NJ 07981

## ACCESS SERVICE

6. Switched Access Service (Cont'd)6.4 Rate Regulations (Cont'd)6.4.1 Description and Application of Rates and Charges  
(Cont'd)(C) Application of Rates (Cont'd)(1) Premium Rates (Cont'd)

In addition, premium rates always apply to the following Local Transport rate elements:

- Entrance Facility
- Direct Trunked Facility
- Direct Trunked Termination
- Multiplexing
- Tandem Switched Facility
- Tandem Switched Termination
- Tandem Switching
- Joint Tandem Switched Transport (N)  
(originating toll free minutes only) (N)

(2) Non-premium Rates

Non-premium rates do not apply to the following Local Transport rate elements:

- Entrance Facility
- Direct Trunked Facility
- Direct Trunked Termination
- Multiplexing
- Tandem Switched Facility
- Tandem Switched Termination
- Tandem Switching
- Joint Tandem Switched Transport (N)  
(originating toll free minutes only) (N)

Non-premium rates (i.e., discounted access minute rates) apply to all FGA and FGB access minutes (measured or assumed) originating or terminating in an end office which is not equipped with equal access capabilities. Non-premium rates do not apply to FGA and FGB access minutes when utilized in the provision of MTS/WATS service.

In addition, non-premium rates apply to FGC access minutes originating in an end office which is not equipped with equal access capabilities when the FGC service is used in conjunction with the Interim NXX Translation optional feature or Toll Free Database Access Service by customers who do not furnish interstate MTS/WATS. (T)  
(T)

Non-premium rates do not apply to FGB ADA access minutes.

Transmittal No. 1635

Issued: June 16, 2021

Effective: July 1, 2021

ACCESS SERVICE

APPROVED

6. Switched Access Service (Cont'd)

6.4 Rate Regulations (Cont'd)

6.4.1 Description and Application of Rates and Charges  
(Cont'd)

(C) Application of Rates (Cont'd)

(3) Abbreviated Dialing Arrangement (ADA)

At end offices that are equipped with equal access capabilities, premium rates apply to all FGB with ADA access minutes.

At end offices that are not equipped with equal access capabilities:

- Premium rates multiplied by the ADA rate factor set forth in 17.2.4 following apply to the following FGB rate elements:

- Local Switching
- Information Surcharge

(D)

- Premium rates apply to the following FGB rate elements with ADA access minutes:

- Entrance Facility
- Direct Trunked Termination
- Directed Trunked Facility
- Tandem Switched Termination
- Tandem Switched Facility
- Tandem Switching
- Multiplexing

Transmittal No. 919

2006 2

Issued: December 17, 2001

Effective: ~~January 1, 2002~~

Director - Access Tariffs  
80 So. Jefferson Road, Whippany, NJ 07981

## ACCESS SERVICE

6. Switched Access Service (Cont'd)6.4 Rate Regulations (Cont'd)6.4.1 Description and Application of Rates and Charges (Cont'd)(C) Application of Rates (Cont'd)(4) Transition Billing Arrangement

When FGA, or FGB Switched Access Service, except as set forth in (1) preceding, provided to an entry switch (i.e., dial tone office for FGA and access tandem for FGB) has usage originating from and/or terminating at both end offices that have been converted to equal access and end offices that have not been converted, the premium and non-premium rates will apply in the following manner:

- (a) All access minutes that originate from or terminate at the equal access end office(s) will be billed at premium rates. Access minutes that originate from or terminate at end offices not equipped with equal access capabilities, hereinafter referred to as non-premium access minutes, will continue to be billed at non-premium rates. Non-premium rates will apply as follows depending on the type of service.
  - (i) For FGA and FGB services, the number of non-premium access minutes to be billed at non-premium rates is derived by subtracting the number of premium rated access minutes from the total number of access minutes.
  - (ii) Premium access minutes will be determined as set forth in (b) following.

(x) Issued to reflect new corporate address.

Transmittal No. 855

Issued: February 23, 2000

Effective: March 9, 2000

Director - Access Tariffs  
80 So. Jefferson Road, Whippany, NJ 07981

## ACCESS SERVICE

6. Switched Access Service (Cont'd)6.4 Rate Regulations (Cont'd)6.4.1 Description and Application of Rates and Charges (Cont'd)(C) Application of Rates (Cont'd)(4) Transition Billing Arrangement (Cont'd)

(b) The number of access minutes to be rated as premium access minutes is determined as follows:

- (i) Where end office specific usage data is available, premium rates apply to the measured access minutes originating from or terminating at the equal access end office(s).
- (ii) Where end office specific usage data is not available for originating and/or terminating FGA or FGB, the total originating and/or terminating usage will be measured or assumed usage at the entry switch as set forth respectively in 6.5.4 and 6.6.4 following. Originating and/or terminating usage will then be apportioned between premium and non-premium access minutes.

(x) Issued to reflect new corporate address.

Transmittal No. 855

Issued: February 23, 2000

Effective: March 9, 2000

Director - Access Tariffs  
80 So. Jefferson Road, Whippany, NJ 07981

## ACCESS SERVICE

6. Switched Access Service (Cont'd)6.4 Rate Regulations (Cont'd)6.4.1 Description and Application of Rates and Charges (Cont'd)(C) Application of Rates (Cont'd)(4) Transition Billing Arrangement (Cont'd)

## (b) (Cont'd)

## (ii) (Cont'd)

Such apportionment will be based on the ratio of the number of subscriber lines in the access area (i.e., local calling areas for FGA originating minutes, LATA for FGA terminating minutes and end offices subtending the access tandem for FGB minutes) of the first point of switching that are served by equal access end offices to the total number of subscriber lines in that access area. The ratio thus developed is applied to the total measured or assumed originating FGA usage, terminating FGA usage, originating FGB usage or terminating FGB usage, as applicable, to determine the usage to be billed at premium rates, unless adjusted as set forth in (iii) following.

(x) Issued to reflect new corporate address.

Transmittal No. 855

Issued: February 23, 2000

Effective: March 9, 2000

Director - Access Tariffs  
80 So. Jefferson Road, Whippany, NJ 07981

## ACCESS SERVICE

6. Switched Access Service (Cont'd)6.4 Rate Regulations (Cont'd)6.4.1 Description and Application of Rates and Charges (Cont'd)(C) Application of Rates (Cont'd)(4) Transition Billing Arrangement (Cont'd)

(b) (Cont'd)

(ii) (Cont'd)

The ratios used to calculate the premium usage will be determined on a quarterly basis. The ratios to be used for the succeeding quarter will be provided to the customer with the last bill rendered in the quarter or mailed separately within five working days after the first day of the new quarter (i.e., January, April, July and October).

For purposes of administering this provision: (1) subscriber lines are defined as exchange service lines, Centrex lines and Centrex-type lines provided by the Telephone Company under its local and/or general exchange service tariff; (2) the access area is defined as the local calling area of the dial tone office for originating FGA, the entire LATA for terminating FGA, and all end offices subtending the access tandem for originating and terminating FGB; and (3) the local calling area of the dial tone office is as defined in the Telephone Company's local and/or general exchange service tariff.

(x) Issued to reflect new corporate address.

Transmittal No. 855

Issued: February 23, 2000

Effective: March 9, 2000

Director - Access Tariffs  
80 So. Jefferson Road, Whippany, NJ 07981



## ACCESS SERVICE

6. Switched Access Service (Cont'd)6.4 Rate Regulations (Cont'd)6.4.1 Description and Application of Rates and Charges  
(Cont'd)(C) Application of Rates (Cont'd)(4) Transition Billing Arrangement (Cont'd)

## (b) (Cont'd)

(iii) Where FGD Switched Access Service is provided to a customer in an end office(s) where that customer's FGA or FGB premium access minutes have been determined in accordance with (ii) preceding, such premium access minutes will be adjusted in the following manner. For each FGD access minute originating from or terminating at that end office, excluding those FGD minutes of use associated with Operator Transfer Service, the originating or terminating FGA or FGB premium access minutes determined as set forth in (ii) preceding will be reduced on a one for one basis, but in no event shall the reduction exceed the total number of FGA or FGB premium access minutes originating from or terminating at that end office. For each FGA or FGB premium minute of use reduction in either the originating or terminating direction, a corresponding originating or terminating non-premium minute of use will be apportioned to those end offices in the access area that are non-equal. Such apportionment will be based upon a ratio of the number of subscriber lines in each non-equal end office to the total subscriber lines that are served by all non-equal end offices in the access area. The customer will be billed for the revised number of premium or non-premium access minutes.

(x) Issued to reflect new corporate address.

Transmittal No. 855

Issued: February 23, 2000

Effective: March 9, 2000

Director - Access Tariffs  
80 So. Jefferson Road, Whippany, NJ 07981

## ACCESS SERVICE

6. Switched Access Service (Cont'd)6.4 Rate Regulations (Cont'd)6.4.1 Description and Application of Rates and Charges (Cont'd)(C) Application of Rates (Cont'd)(5) Unmeasured FGA and FGB Access Services

Where originating and/or terminating measurement capability does not exist for Feature Group A or Feature Group B Switched Access Services provided to the first point of switching, the number of access minutes that will be assumed are as set forth following in 6.5.4 and 6.6.4 respectively.

(6) Notice of Equal Access Conversion

The Telephone Company will provide written notification to all access customers of record within a particular LATA that an end office in that LATA is scheduled to be converted to an equal access end office. This notification will be sent, via certified U.S. Mail, to each customer of record in the LATA where the conversion is scheduled to occur, at least six months in advance of the conversion date.

The customer will have the choice of converting all or part of the existing services to equal access (i.e., Feature Group D) or retaining the existing services. The conversion of existing services will be at no charge provided the order to convert such services to Feature Group D is received as set forth in 6.4.3 following. Premium rates will apply to the total access minutes beginning on the actual conversion date, whether the customer chooses to convert to FGD or retain existing services.

(x) Issued to reflect new corporate address.

Transmittal No. 855

Issued: February 23, 2000

Effective: March 9, 2000

Director - Access Tariffs  
80 So. Jefferson Road, Whippany, NJ 07981

ACCESS SERVICE

6. Switched Access Service (Cont'd)

6.4 Rate Regulations (Cont'd)

6.4.1 Description and Application of Rates and Charges  
 (Cont'd)

(C) Application of Rates (Cont'd)

(7) Common Channel Signaling/Signaling System 7  
 (CCS/SS7) Network Connection Service

The CCS/SS7 Network Connection is comprised of a Signaling Mileage Facility charge, a Signaling Mileage Termination charge, a Signaling Entrance Facility charge, and a Signaling Transfer Point (STP) Port charge.

The Signaling Mileage Facility charge is assessed on a per facility per mile basis. The Signaling Mileage Termination charge is assessed on a per termination basis (i.e., at each end of the Signaling Mileage Facility). When the Signaling Mileage Facility mileage measurement is zero, Signaling Mileage Termination charges do not apply.

The Signaling Entrance Facility charge is assessed on a per facility basis for the connection between the customer's designated premises (Signaling Point of Interface) and the serving wire center of that premises.

The STP Port charge is assessed on a per port basis for each termination of a Signaling Mileage Facility at an STP.

(8) Toll Free Database Access Service (T)

A Basic Query or Vertical Feature Query charge applies for each completed query that is returned from the toll free database identifying the customer to whom the call will be delivered whether or not the actual call is delivered to the customer. The query is considered completed when the appropriate call routing information is returned to the Service Switching Point (SSP) that launched the query (T)  
 (T)

Certain material formerly found on this page now appears on 7th Revised Page 6-40.

Transmittal No. 1635

Issued: June 16, 2021

Effective: July 1, 2021

Senior Director - Access Tariffs & Costs  
 60 Columbia Road, Bldg. A - 2nd Fl., Morristown, NJ 07960

ACCESS SERVICE

6. Switched Access Service (Cont'd)

6.4 Rate Regulations (Cont'd)

6.4.1 Description and Application of Rates and Charges  
 (Cont'd)

(C) Application of Rates (Cont'd)

(8) Toll Free Database Access Service (Cont'd) (T)

and the results are transmitted to the next company in the call path. If the originating company transmits the results of the query, it will assess the query charge per call. However, when the originating company is unable to do so, the next company in the call path that is able to launch and transmit the results of the query will assess the query charge. Only one query charge per call may be assessed. Query charges, as set forth in 17.2.2(B), following, will only be applied by those companies whose wire centers are identified as assessing query charges in the NATIONAL EXCHANGE CARRIER ASSOCIATION, INC. TARIFF F.C.C. NO. 4 and when the query is completed. (C)

When Feature Group C or Feature Group D switched access service is used for the provision of Toll Free Database Access Service and the total minutes of use can be determined for each customer at a tandem or SSP but can not be determined by individual end office, an allocation method will be utilized to determine minutes of use by end office and customer. For each end office a ratio will be developed and applied against the total minutes of use for a given customer as determined by the tandem or SSP. These ratios will be developed by dividing the unidentified originating 800 series minutes of use at an end office by the total unidentified originating minutes of (T)

Certain material currently found on this page previously appeared on 8th Revised Page 6-39.

Certain material formerly found of this page now appears on 4th Revised Page 6-41.

Transmittal No. 1635

Issued: June 16, 2021

Effective: July 1, 2021

Senior Director - Access Tariffs & Costs  
 60 Columbia Road, Bldg. A - 2nd Fl., Morristown, NJ 07960

ACCESS SERVICE

6. Switched Access Service (Cont'd)

6.4 Rate Regulations (Cont'd)

6.4.1 Description and Application of Rates and Charges  
 (Cont'd)

(C) Application of Rates (Cont'd)

(8) Toll Free Database Access Service (Cont'd)

use in all end offices subtending the tandem or SSP. For example, assume:

- Three end offices (EO-1, EO-2, and EO-3) subtend a tandem

EO-1 measures 2,000 minutes of 800 series use	
EO-2 measures 3,000 minutes of 800 series use	
EO-3 measures <u>5,000</u> minutes of 800 series use	
10,000	TOTAL

- The tandem delivers 800 series usage to two customers:

IC-A has 4,000 minutes of use  
 IC-B has 6,000 minutes of use

- The allocation ratio for EO-1 is 20%

2,000/10,000

- The minutes of use to be billed by EO-1 are

800 to IC-A (20% X 4,000)	
<u>1,200</u> to IC-B (20% X 6,000)	
2,000	TOTAL

(M)

(T)

(M)

Certain material currently found on this page previously appeared on 6th Revised Page 6-40.

Transmittal No. 1635

Issued: June 16, 2021

Effective: July 1, 2021

Senior Director - Access Tariffs & Costs  
 60 Columbia Road, Bldg. A - 2nd Fl., Morristown, NJ 07960

ACCESS SERVICE

6. Switched Access Service (Cont'd)

6.4 Rate Regulations (Cont'd)

6.4.1 Description and Application of Rates and Charges (Cont'd)

(C) Application of Rates (Cont'd)

This page intentionally left blank.

(x) Issued to reflect new corporate address.

Transmittal No. 855

Issued: February 23, 2000

Effective: March 9, 2000

Director - Access Tariffs  
80 So. Jefferson Road, Whippany, NJ 07981

ACCESS SERVICE

6. Switched Access Service (Cont'd)

6.4 Rate Regulations (Cont'd)

6.4.1 Description and Application of Rates and Charges (Cont'd)

(C) Application of Rates (Cont'd)

This page intentionally left blank.

(x) Issued to reflect new corporate address.

Transmittal No. 855

Issued: February 23, 2000

Effective: March 9, 2000

Director - Access Tariffs  
80 So. Jefferson Road, Whippany, NJ 07981

ACCESS SERVICE

6. Switched Access Service (Cont'd)

6.4 Rate Regulations (Cont'd)

6.4.1 Description and Application of Rates and Charges (Cont'd)

(C) Application of Rates (Cont'd)

This page intentionally left blank.

(x) Issued to reflect new corporate address.

Transmittal No. 855

Issued: February 23, 2000

Effective: March 9, 2000

Director - Access Tariffs  
80 So. Jefferson Road, Whippany, NJ 07981



ACCESS SERVICE

6. Switched Access Service (Cont'd)

6.4 Rate Regulations (Cont'd)

6.4.2 Minimum Monthly Charge

Switched Access Service is subject to a minimum monthly charge. The minimum charge applies for the total capacity provided. The minimum monthly charge is calculated as follows.

For usage rated Local Transport, Local Switching and Information Surcharge rate elements, the minimum monthly charge is the sum of the recurring charges set forth in Sections 17.2.2 and 17.2.3, following, for either the actual measured usage or the assumed usage prorated to the number of days or major fraction of days based on a 30 day month. (T)

For flat rated Local Transport rate elements, the minimum monthly charge is the sum of the recurring charges set forth in Section 17.2.2, following, prorated to the number of days or major fraction of days on a 30 day month. (T)

Transmittal No. 1192

Issued: December 17, 2007

Effective:

Director - Access Tariffs  
80 So. Jefferson Road, Whippany, NJ 07981

3 3 0

## ACCESS SERVICE

6. Switched Access Service (Cont'd)6.4 Rate Regulations (Cont'd)6.4.3 Change of Switched Access Service Arrangements

Changes from one type of Feature Group to another will be treated as a discontinuance of one type of service and a start of another. Nonrecurring charges will apply, with one exception. When a customer upgrades a Feature Group A or B service to a Feature Group D service and when Feature Group C is upgraded to Feature Group D coincident with the availability of Feature Group D in an end office, the nonrecurring charges associated with the equal access conversion will not apply. Nonrecurring charges for other associated service requests, (e.g., a simultaneous change from multifrequency address signaling to SS7 signalling) will apply. Minimum period obligations will not change, i.e., the time elapsed in the existing minimum period obligation will be credited to the minimum period obligations for FGD service, subject to the following limitations.

In order to avoid the imposition of nonrecurring charges a customer which is a participant in the presubscription allocation process (i.e., is on the presubscription ballot) must:

- submit its order to disconnect Feature Group A and/or B within 30 days after the date the results of the final allocation of customers in an end office are actually received by the customer, and
- make the effective date for disconnection of the Feature Group A and/or B Access Services no later than 60 days after the final allocation results are received by the customer.

A customer which is not a participant in the allocation process (i.e., is not on the presubscription ballot) is subject to the same rules preceding. The time frames for the non-participating customer(s) are the same as those which apply to the last customer to receive the results of the final allocation of customers in an end office who is a participant in the allocation process. For all other changes from one type of Feature Group to another, new minimum period obligations will be established.

(x) Issued to reflect new corporate address.

Transmittal No. 855

Issued: February 23, 2000

Effective: March 9, 2000

Director - Access Tariffs  
80 So. Jefferson Road, Whippany, NJ 07981

## ACCESS SERVICE

6. Switched Access Service (Cont'd)6.4 Rate Regulations (Cont'd)6.4.4 Moves

A move involves a change in the physical location of one of the following:

- The point of termination at the customer designated premises
- The customer designated premises

The charges for the move are dependent on whether the move is to a new location within the same building or to a different building.

(A) Moves Within the Same Building

When the move is to a new location within the same building, the charge for the move will be an amount equal to one half of the installation nonrecurring charge for the capacity affected. This charge is in addition to the Access Order Charge as specified in 17.4.1(A) following. There will be no change in the minimum period requirements.

(B) Moves to a Different Building

Moves to a different building will be treated as a discontinuance and start of service and all associated nonrecurring charges will apply. New minimum period requirements will be established for the new service. The customer will also remain responsible for satisfying all outstanding minimum period charges for the discontinued service.

6.4.5 Local Information Delivery Services

Calls over Switched Access Service in the terminating direction to certain community information services will be rated under the applicable rates for Switched Access Service as set forth in 17.2 following. In addition, the charges per call as specified under the Telephone Company's local and/or general exchange service tariffs, e.g., 976 (DIAL-IT) Network Services, will also apply.

(x) Issued to reflect new corporate address.

Transmittal No. 855

Issued: February 23, 2000

Effective: March 9, 2000

Director - Access Tariffs  
80 So. Jefferson Road, Whippany, NJ 07981

## ACCESS SERVICE

6. Switched Access Service (Cont'd)6.4 Rate Regulations (Cont'd)6.4.6 Mileage Measurement

The mileage to be used to determine the monthly rate for Local Transport is calculated on airline distances between the end office switch, which may be a Remote Switching Module, (where the call carried by Local Transport originates or terminates) and the customer's serving wire center or between an end office switch, which may be a Remote Switching Module (where the call carried by Local Transport terminates) and an IPG SWC when the customer uses Feature Group D in conjunction with IPG as described in Section 16.4, following. When Direct Trunked Transport is ordered between the serving wire center and the end office, mileage is normally measured in one segment from the serving wire center to the end office. When Direct Trunked Transport is ordered between a serving wire center and a tandem and Tandem Switched Transport is ordered between the tandem and the end office, mileage is calculated separately for each segment. Exceptions to these methods are as set forth in (B) through (J) following. For SS7 signaling, the mileage to be used to determine the monthly rate for the Signaling Mileage Facility is calculated on the airline distance between the serving wire center associated with the customer's designated premises (Signaling Point of Interface) and the Telephone Company wire center providing the STP Port.

(C)

Where applicable, the V&H coordinates method is used to determine mileage. This method is set forth in the NATIONAL EXCHANGE CARRIER ASSOCIATION, INC. TARIFF F.C.C. NO. 4 for Wire Center Information (V&H coordinates).

Transmittal No. 1309

Issued: April 15, 2011

Effective: " - - - - -

JUN 06 2011

Director - Access Tariffs  
80 So. Jefferson Road, Whippany, NJ 07981

ACCESS SERVICE

6. Switched Access Service (Cont'd)

6.4 Rate Regulations (Cont'd)

6.4.6 Mileage Measurement (Cont'd)

Mileage rates are as set forth in Section 17.2.2, following. To determine the rate to be billed, first compute the airline mileage using the V&H coordinates method. If the calculation results in a fraction of a mile, always round up to the next whole mile before determining the mileage and applying the rates. Then multiply the mileage by the appropriate rate.

(T) (M)

Exceptions to the mileage measurement rules are as follows:

(A) Reserved for Future Use

(M)

(B) Feature Group A - Originating Usage

Direct Trunked Transport Mileage for premium and non-premium rated access minutes in the originating direction over Feature Group A Switched Access Service will be calculated on an airline basis, using the V&H coordinates method. The mileage measurement will be between the first point of switching (end office switch where the Feature Group A switching dial tone is provided) and the customer's serving wire center for the Switched Access Service provided.

Certain material currently found on this page previously appeared on 7th Revised Page 6-48.

Certain material previously found on this page now appears on 4th Revised Page 6-50.

Transmittal No. 1257

Issued: November 13, 2009

Effective: *April 14, 2010*

Director - Access Tariffs  
80 So. Jefferson Road, Whippany, NJ 07981

ACCESS SERVICE

6. Switched Access Service (Cont'd)

6.4 Rate Regulations (Cont'd)

6.4.6 Mileage Measurement (Cont'd)

(T)

(C) Feature Group A - Terminating Usage

(M)

The Local Transport mileage for terminating Feature Group A Switched Access Service when the Telephone Company provides Direct Trunked Transport will be measured in two segments. Direct Trunked Transport mileage will be measured between the customer's serving wire center and the first point of switching (i.e., the end office switch where the Feature Group A switching dial tone is provided). Tandem Switched Transport mileage will be measured between the first point of switching and the terminating end office.

(M)

Certain material currently found on this page previously appeared on 9th Revised Page 6-49.

Transmittal No. 1257

Issued: November 13, 2009

Effective: *April 14, 2010*

Director - Access Tariffs  
80 So. Jefferson Road, Whippany, NJ 07981

## ACCESS SERVICE

6. Switched Access Service (Cont'd)6.4 Rate Regulations (Cont'd)6.4.6 Mileage Measurement (Cont'd)

(D) Feature Groups B, C and D - Alternate Traffic Routing  
When the Alternate Traffic Routing optional feature is provided with Feature Groups B, C or D, the Local Transport access minutes will be apportioned between the two trunk groups used to provide this feature. Such apportionment will be made using: (1) actual minutes of use if available, (2) standard Telephone Company traffic engineering methodology and will be based on the last trunk CCS desired for the high usage group, as described in 6.10.1(L) following (Alternate Traffic Routing), and the total busy hour minutes of capacity ordered to the end office, when the feature is provided at an end office switch, or to the subtending end offices when the feature is provided at an access tandem switch, or (3) an apportionment mutually agreed to by the Telephone Company and the customer. This apportionment will serve as the basis for Local Transport calculation.

(E) Feature Group C - Multiple CDPs  
When terminating Feature Group C Switched Access Service is provided from multiple customer designated premises to an end office not equipped with measurement capabilities, the total Local Transport access minutes for that end office will be apportioned among the trunk groups accessing the end office on the basis of the individual busy hour minutes of capacity ordered for each of those trunk groups. This apportionment will serve as the basis for Local Transport mileage calculation.

(x) Issued to reflect new corporate address.

Transmittal No. 855

Issued: February 23, 2000

Effective: March 9, 2000

Director - Access Tariffs  
80 So. Jefferson Road, Whippany, NJ 07981

## ACCESS SERVICE

6. Switched Access Service (Cont'd)6.4 Rate Regulations (Cont'd)6.4.6 Mileage Measurement (Cont'd)(F) Feature Groups A, B, C and D - WATS

The Local Transport Facility for Feature Groups A, B, C and D Switched Access Service connected with Special Access Service at a WATS Serving Office will be measured between the WATS Serving Office (when measured access minutes of use are used) or between the Feature Group A entry switch (when assumed minutes of use are used) and the serving wire center for the customer designated premises.

(G) Feature Groups B and D - WSCs Directly Interconnected to Access Tandems

The Local Transport mileage for Feature Groups B and D switched access service provided to Wireless Switching Centers (WSCs) directly interconnected to a Telephone Company access tandem office will be determined on an airline basis, using the V&H coordinate method. The mileage will be measured between the customer's serving wire center and the Telephone Company access tandem office to which the WSC is interconnected.

(H) Feature Groups B, C, and D - Remote Offices

Local Transport mileage for Feature Groups B, C, and D Switched Access Service provided to a Remote Office will be measured in multiple segments.

When the facility is directly trunked to the Host Office, Direct Trunked Facility mileage will be measured between the customer's serving wire center and the Host Office, and Tandem Switched Facility mileage will be measured between the Host Office and the Remote Office. The Tandem Switching charge will not apply.

When the facility is routed through a tandem to the Host Office, Direct Trunked Facility will be measured from the Serving Wire Center to the tandem, Tandem Switched Facility will be measured from the tandem to the host, and another segment of Tandem Switched Facility will be measured from the host to the remote. A Tandem Switching charge will be applicable at the tandem.

(x) Issued to reflect new corporate address.

Transmittal No. 855

Issued: February 23, 2000

Effective: March 9, 2000

Director - Access Tariffs  
80 So. Jefferson Road, Whippany, NJ 07981



ACCESS SERVICE

6. Switched Access Service (Cont'd)

6.4 Rate Regulations (Cont'd)

6.4.6 Mileage Measurement (Cont'd)

(I) Use of Telephone Company Hub

When multiplexing is performed at Telephone Company Hubs, mileage is computed and rates applied separately for each segment of the Local Transport Direct Trunked Facility (i.e., customer serving wire center to Hub, Hub to Hub, and/or Hub to end office).

(J) Feature Group D - Connected with Internet Protocol Gateway Access Service

When required, the Tandem Switched Facility mileage for Feature Group D Switched Access Service connected with IPG will be measured as described below.

When the IPG SWC is located at the Telephone Company's tandem office and traffic is to be originated from or terminated to the end office, the Tandem Switched Facility mileage will be measured between the IPG SWC and the end office.

- When the IPG SWC is located at the Telephone Company's tandem office and traffic is to be originated from or terminated to a host/remote complex, the Tandem Switched Facility mileage will be measured in multiple segments. The first segment will be measured between the IPG SWC and the host office and the second segment will be measured between the host office and subtending remote office.

- When the IPG SWC is located at the Telephone Company's host office and traffic is to be originated from or terminated to the remote office, the Tandem Switched Facility mileage will be measured between the IPG SWC and the subtending remote office.

Transmittal No. 1309

Issued: April 15, 2011

Effective:

Director - Access Tariffs  
 80 So. Jefferson Road, Whippany, NJ 07981

JUN 06 2011

ACCESS SERVICE

6. Switched Access Service (Cont'd)

6.4 Rate Regulations (Cont'd)

6.4.7 Mixed Use

Mixed use occurs when Switched Access Service and Special Access Service are provided over the same High Capacity or Synchronous Optical Channel facilities through a common interface. The regulations governing the provision of Mixed Use Facilities are set forth in Section 5.2.4, preceding, and Section 7.2.7, following.

(T)

Mixed use also occurs when Ethernet Switched Access Local Transport and Ethernet Transport Service (ETS) are provided over the same ETS facilities through a common interface. The regulations governing the provision of Mixed Use Facilities for these services are set forth in Section 5.2.4, preceding, and Section 16.3.4(D), following.

(N)

(N)

The Telephone Company will designate the first point(s) of switching and routing to be used where equal access traffic is provided through a centralized equal access arrangement. Those Telephone Company offices providing equal access through centralized arrangements are identified in NATIONAL EXCHANGE CARRIER ASSOCIATION, INC. TARIFF F.C.C. NO. 4.

Certain material previously found on this page now appears on Original Page 6-52.1.

Transmittal No. 1403

Issued: November 7, 2013

Effective: November 22, 2013

Director - Access Tariffs  
80 So. Jefferson Road, Whippany, NJ 07981

ACCESS SERVICE

6. Switched Access Service (Cont'd)

6.4 Rate Regulations (Cont'd)

6.4.8 Message Unit Credit for Feature Group A

Calls from end users to the seven digit local telephone numbers associated with Feature Group A Switched Access Service are subject to Telephone Company local and/or general exchange service tariff charges (including message unit and toll charges as applicable). The monthly bills rendered to customers for their Feature Group A Switched Access Service will include a credit to reflect any message unit charges collected from their end users under the Telephone Company's local and/or general exchange service tariffs. When the customer is provided FGA service where measurement capability does not exist, the credit will apply to access minutes not to exceed the assumed originating access minutes. No credit will apply for any terminating FGA access minutes. The message unit credit for originating access minutes will be based on the generally applicable message unit charges of the Telephone Company.

(N)

(N)

(M)

(M)

Certain material currently found on this page previously appeared on 4th Revised Page 6-52.

Transmittal No. 1403

Issued: November 7, 2013

Effective: November 22, 2013

Director - Access Tariffs  
80 So. Jefferson Road, Whippany, NJ 07981

ACCESS SERVICE

6. Switched Access Service (Cont'd)

6.4 Rate Regulations (Cont'd)

6.4.9 Application of Rates for Feature Group A Extension Service

Feature Group A Switched Access Service is available with extensions, i.e., additional terminations of the service at different customer designated premises in the same LATA as the FGA dial tone office or a LATA other than the LATA where the FGA dial tone office is located. Feature Group A extensions within the same LATA and same state as the dial tone office are provided and charged under the Telephone Company's local and/or general exchange service tariffs. Feature Group A extensions located in a LATA other than the LATA where the dial tone office is located or in a different state in the same LATA as the dial tone office are provided and charged as Special Access Service. The rate elements which apply are: A Voice Grade Channel Termination, Channel Mileage, if applicable, and Signaling Capability (optional features and functions), if applicable. All appropriate monthly rates and nonrecurring charges set forth in 17.3.4 following will apply.

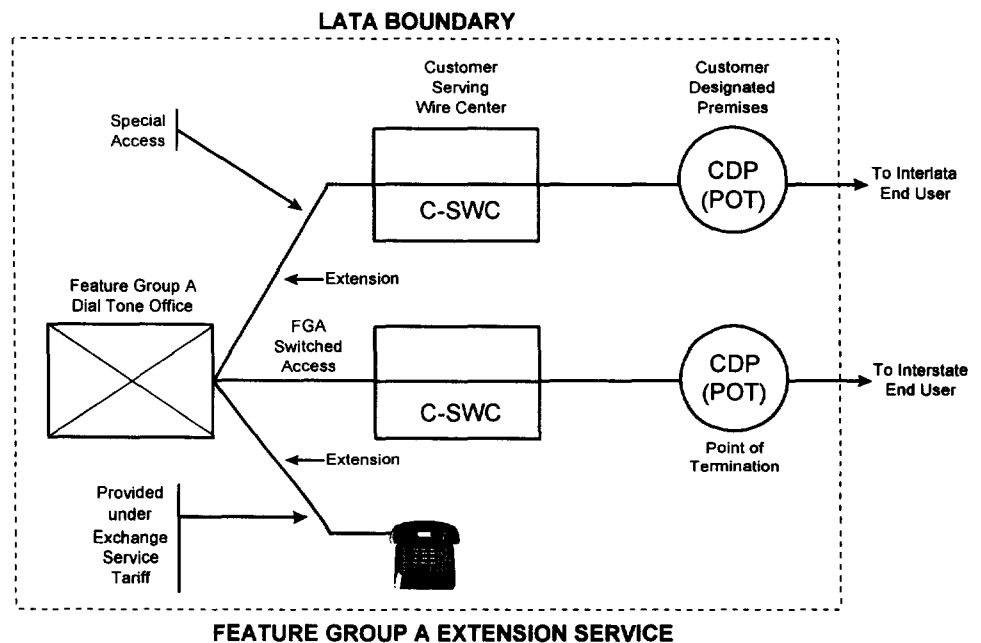

In the above example, two CDPs are utilized to better illustrate the concept. From a practical standpoint, both the Switched Access and Special Access Services could be routed via the same CDP.

(x) Issued to reflect new corporate address.

Transmittal No. 855

Issued: February 23, 2000

Effective: March 9, 2000

Director - Access Tariffs  
 80 So. Jefferson Road, Whippany, NJ 07981