

ACCESS SERVICE

16. Public Packet Data Network

Public Packet Data Networks utilize separate data networks, comprised of switching, routing and transmission facilities. The networks provide for the transfer of data provided by a customer in a frame or cell format. The data is separated into discrete segments for transmission through the public packet data network.

16.1 Frame Relay Access Service

16.1.1 General

(A) General

Frame Relay Access Service (FRAS) is a medium-speed, connection-oriented packet-switched data service that allows for the interconnection of Local Area Networks (LANs) or other compatible customer premises equipment for the purpose of connecting to an interstate frame relay network. FRAS also allows for the interconnection of a customer designated premises to a DSL Access Service Connection Point as described in Section 8, preceding. The terminal equipment accumulates the customer data and puts it into a frame relay format suitable for transmission over the FRAS network. This terminal equipment must conform to the requirements specified in the following Technical References:

- ITU-CCITT I.233.1,
- ITU-CCITT I.233.2,
- ITU-CCITT I.370, and
- ITU-T Q.933

(T)
|
(T)

FRAS permits customers to share network bandwidth for data transmissions.

Transmittal No. 1231

Issued: January 16, 2009

Effective: *MARCH 26, 2009*

ACCESS SERVICE

16. Public Packet Data Network

16.1 Frame Relay Access Service

16.1.1 General (Con'd)

(A) General (Cont'd)

Rates and charges for FRAS are set forth in Section 17.4.8.1, following. The Telephone Company specific rate band assignment for the FRAS rate elements is specified in the Special Access (SPA) column in Section 17.5.1, following. The application of rates for FRAS is described in Section 16.1.2, following.

(T)
(T)

In addition to the regulations and charges specified in this section, the general regulations and charges specified in other sections of this tariff apply as appropriate.

(B) Service Description

FRAS is a transport service that facilitates the exchange of variable length information units (frames) between customer connections. Frames travel a fixed path through the network with an address that specifies the permanent virtual connection. Addresses are read by the network processor and the frames are relayed to the preassigned destination.

Transmittal No. 1337

Issued: March 16, 2012

Effective: March 31, 2012

Director - Access Tariffs
80 So. Jefferson Road, Whippany, NJ 07981

ACCESS SERVICE

16. Public Packet Data Network (Cont'd)16.1 Frame Relay Access Service (Cont'd)16.1.1 General (Cont'd)(B) Service Description (Cont'd)

FRAS service includes: the Frame Relay Access Connection, the Frame Relay Inter-network Connection, and Permanent Virtual Connections (PVC) which have associated Committed Information Rates (CIRs).

The Frame Relay Access Connection and the Frame Relay Inter-network Connection elements provide access to a Telephone Company wire center equipped with a frame relay switch. A generic view of FRAS access is shown in 16.1.2(A) following. Frame Relay Access Service connections are available from the wire centers as identified in NATIONAL EXCHANGE CARRIER ASSOCIATION, INC. TARIFF F.C.C. No. 4.

The Frame Relay Access Connection combines a frame relay compatible 56.0 kbps, 64.0 kbps, 1.544 Mbps or 44.736 Mbps digital transport facility with a port on a frame relay switch. The Frame Relay Access Connection includes the Telephone Company facility between the customer designated premises and the customer's serving wire center, the interoffice transport (if applicable) between the customer's serving wire center and a wire center equipped with a frame relay switch, and the end user port. The end user port is a user-to-network interface which provides the lineside physical entry point into the Telephone Company frame relay network and permits FRAS compatible end user customer premises equipment (CPE) to originate or terminate an interstate access service. Connections between end user customer premises equipment and the Telephone Company frame relay switch are available at speeds of 56.0 kbps, 64.0 kbps, 1.544 Mbps or 44.736 Mbps. Each end user port requires the identification of a corresponding terminating port. All end user ports must be in conformance with the Technical References specified in (A), above.

(T)
(T)

Transmittal No. 1231

Issued: January 16, 2009

Effective:

March 26, 2009

Director - Access Tariffs
80 So. Jefferson Road, Whippany, NJ 07981

ACCESS SERVICE

16. Public Packet Data Network (Cont'd)

16.1 Frame Relay Access Service (Cont'd)

16.1.1 General (Cont'd)

(B) Service Description (Cont'd)

The Frame Relay Inter-network Connection combines a frame relay compatible 1.544 Mbps or 44.736 Mbps digital transport facility with a port on a frame relay switch. The Frame Relay Inter-network Connection includes the Telephone Company facility between the customer designated premises and the customer's serving wire center, the interoffice transport (if applicable) between the customer's serving wire center and a wire center equipped with a frame relay switch, and the inter-network customer port. The inter-network customer port is a network-to-network interface which provides the trunkside physical entry point into the Telephone Company frame relay network. The inter-network customer port connects the Telephone Company frame relay switch and the access customer's network. The inter-network customer port is offered at speeds of 1.544 Mbps or 44.736 Mbps. All inter-network customer ports must be in conformance with Telcordia Technologies, Inc. Technical Reference TR-TSV-001370, Issued: May 1993.

The Telephone Company will provide the logical circuits required within its frame relay network to connect the ports or to connect a port with a DSL Access Service Connection Point. These logical circuits, or Permanent Virtual Connections (PVC), are software defined, end-to end, bi-directional communications paths that are established and dis-established via the access service order process. While no physical circuits are dedicated, the two network addresses (one from each port) are connected electronically to form a PVC.

There are two types of PVCs available. The standard PVC establishes a communications path within the Telephone Company's frame relay network between two ports or between a port and a DSL Access Service Connection Point. The extended PVC establishes a communications path on two interconnected telephone companies' frame relay networks located in adjacent serving territories between two ports or between a port and a DSL Access Service Connection Point.

(C)
|
(C)
(D)
(D)

7 · 24 · 02

Transmittal No. 933

8 · - 7 · 02

Issued: ~~April 16, 2002~~

Effective: ~~May 1, 2002~~

Director - Access Tariffs
80 So. Jefferson Road, Whippany, NJ 07981

ACCESS SERVICE

16. Public Packet Data Network (Cont'd)

16.1 Frame Relay Access Service (Cont'd)

16.1.1 General (Cont'd)

(B) Service Description (Cont'd)

At the time service is ordered the number of PVCs will be identified along with their Committed Information Rates. CIR is the bit rate at which the FRAS network commits to transfer data. Committed Information Rates provide for frame relay switch throughput at designated speeds (See Section 16.1.2(A)(3), following). This information is required for network routing purposes.

(T)

(C) Service Provided by More than One Telephone Company

There are two types of arrangements available for Frame Relay Access Service (FRAS) when the service is provided by more than one Telephone Company, i.e., Jointly-Provided FRAS and Interconnected FRAS as described below.

(N)

(1) Jointly-Provided FRAS

(N)

When the transport facility between the customer designated premises and a wire center equipped with a frame relay switch is provided by more than one Telephone Company, the Telephone Companies involved will provide a Special Access Service facility as set forth in Section 7 preceding, and in accordance with Sections 2.4.7 and 5.3, preceding.

Jointly-Provided FRAS service includes: the End User Port, the Inter-network Customer Port, and Permanent Virtual Connections (PVC) which have associated Committed Information Rates (CIRs). A Special Access Service facility is used to connect to the frame relay switch.

Connections are provided via Channel Termination(s) and Channel Mileage (See Section 7 Special Access Digital Data and High Capacity Services preceding). All regulations, rates and charges as specified in Section 7 will apply in addition to the rates and charges associated with FRAS. A generic view of jointly-provided FRAS is shown in Section 16.1.2(A), following.

(T)

7 · 24 · 02

Transmittal No. 933

8 · - 7 · 02

Issued: ~~April 16, 2002~~

Effective: ~~May 1, 2002~~

ACCESS SERVICE

16. Public Packet Data Network (Cont'd)

16.1 Frame Relay Access Service (Cont'd)

16.1.1 General (Cont'd)

(C) Service Provided by More than One Telephone Company (Cont'd)

(1) Jointly-Provided FRAS (Cont'd)

(N)

The Telephone Company that provides the frame relay switch will bill an End User Port charge for the end user port connection and/or an Inter-network Customer Port charge for the inter-network customer port connection.

The Special Access Service, End User Port and/or Inter-network Customer Port charge(s) will apply in lieu of the Frame Relay Access Connection or Frame Relay Inter-network Connection.

(2) Interconnected FRAS

(N)

Interconnected FRAS allows the Telephone Company to interconnect its frame relay network with another telephone company's frame relay network. Interconnected FRAS provides connections between telephone companies in adjacent serving territories and in non-adjacent serving territories.

(a) Adjacent Serving Territories

In order to connect the Telephone Company's frame relay switch to a frame relay switch of another telephone company that is located in an adjacent serving territory, the customer must order Extended Permanent Virtual Connections (EPVCs), which have associated CIRs. The EPVCs are in addition to the Frame Relay Access Connection (FRAC) and/or Frame Relay Inter-network Connection (FRIC) that are required to complete the connection from the Customer's Designated Premises (CDP) to the Telephone Company's frame relay switch. A generic view of Interconnected FRAS between adjacent serving territories is shown in Section 16.1.2 (A), following.

(N)

7 · 24 · 02

Transmittal No. 933

8 · - 7 · 02

Issued: ~~April 16, 2002~~

Effective: ~~May 1, 2002~~

ACCESS SERVICE

16. Public Packet Data Network (Cont'd)

16.1 Frame Relay Access Service (Cont'd)

16.1.1 General (Cont'd)

(C) Service Provided by More than One Telephone Company (Cont'd)

(2) Interconnected FRAS (Cont'd)

(b) Non-Adjacent Serving Territories

In order to connect the Telephone Company's frame relay switch to a frame relay switch of another telephone company that is located in a non-adjacent serving territory, the customer must order Inter-network Customer Ports (ICPs) and a High Capacity Special Access Channel Mileage Facility to connect the two networks. These elements are in addition to the FRAC and/or the FRIC and the Standard Permanent Virtual Connections (SPVCs), which have associated CIRS, that are required to complete the connection from the CDP to the Telephone Company's ICP. (T)

Connections between the two Telephone Companies' ICPs are provided using 1.544 Mbps and/or 44.736 Mbps High Capacity Channel Mileage Facility (See Section 7.10 High Capacity Special Access Services preceding). Channel Mileage Termination(s) do not apply. A generic view of Interconnected FRAS between non-adjacent serving territories is shown in Section 16.1.2(A), following.

Transmittal No. 1060

Issued: February 14, 2005

Effective:

4 / 13 / 05

Director - Access Tariffs
80 So. Jefferson Road, Whippany, NJ 07981

ACCESS SERVICE

16. Public Packet Data Network (Cont'd)16.1 Frame Relay Access Service (Cont'd)16.1.1 General (Cont'd)(D) Ordering Options and Conditions

Frame Relay Access Service is ordered under the Access Order provisions set forth in Section 5 preceding. Also included in that section are other charges which may be associated with ordering FRAS (e.g., Service Date Change Charges, Cancellation Charges, etc.)

A minimum of two FRAS connections are required for data to be transported between customer designated premises.

(E) Acceptance Testing

At no additional charge, the Telephone Company will, at the customer's request, cooperatively test at the time of installation.

(x) Issued to reflect new corporate address.

Transmittal No. 855

Issued: February 23, 2000

Effective: March 9, 2000

Director - Access Tariffs
80 So. Jefferson Road, Whippany, NJ 07981

ACCESS SERVICE

16. Public Packet Data Network (Cont'd)

16.1 Frame Relay Access Service (Cont'd)

16.1.2 Rate Regulations

This section contains the specific regulations governing the rates and charges that apply for Frame Relay Access Service.

Frame Relay Access Service is available at the wire centers as identified in NATIONAL EXCHANGE CARRIER ASSOCIATION, INC. TARIFF F.C.C. No. 4. In the case of Interconnected Frame Relay Access Service, NATIONAL EXCHANGE CARRIER ASSOCIATION, INC. TARIFF F.C.C. NO. 4 also identifies the intermediate and super intermediate wire centers.

(A) Rate Categories

The following diagrams depict a generic view of the components of Frame Relay Access Service and the manner in which the components are combined to provide FRAS, Interconnected FRAS, and Jointly-Provided FRAS.

Frame Relay Access Service

Customer's Serving Wire Center is equipped with a frame relay switch

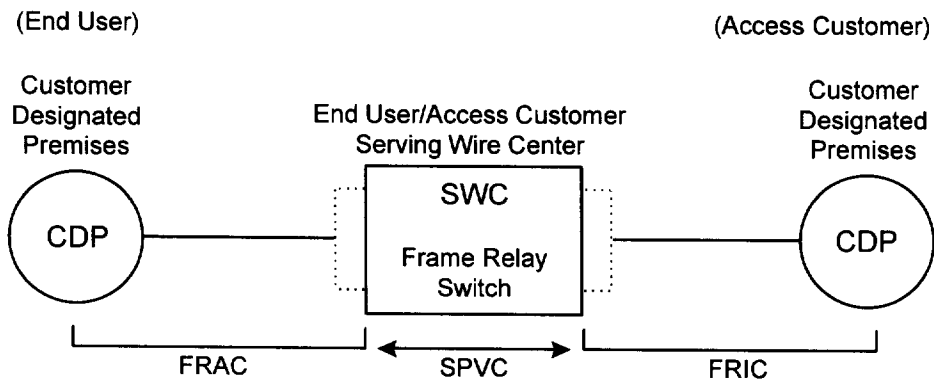

RATE ELEMENTS

- \$ FRAC = Frame Relay Access Connection
- \$ SPVC = Standard Permanent Virtual Connection
- \$ FRIC = Frame Relay Inter-network Connection

(x) Issued to reflect new corporate address.

Transmittal No. 855

Issued: February 23, 2000

Effective: March 9, 2000

Director - Access Tariffs
 80 So. Jefferson Road, Whippany, NJ 07981

ACCESS SERVICE

16. Public Packet Data Network (Cont'd)

16.1 Frame Relay Access Service (Cont'd)

16.1.2 Rate Regulations (Cont'd)

(A) Rate Categories (Cont'd)

Frame Relay Access Service

Customer's Serving Wire Center is not equipped with a frame relay switch

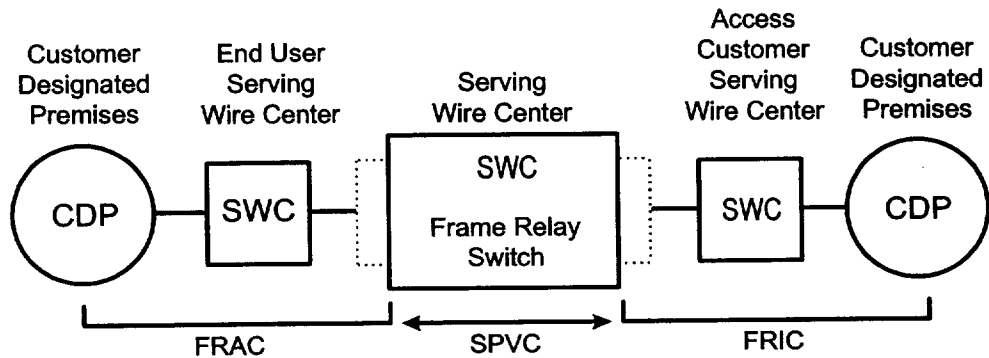

Interconnected FRAS Between Adjacent Serving Territories

(C)

EC A *

EC B *

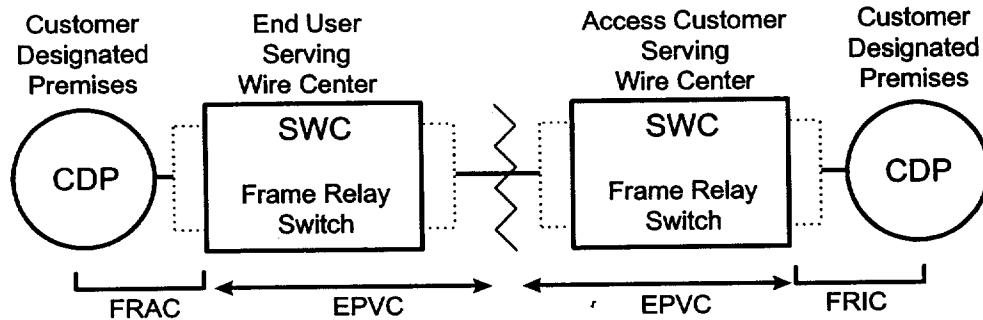

RATE ELEMENTS

- FRAC = Frame Relay Access Connection
- EPVC = Extended Permanent Virtual Connection
- FRIC = Frame Relay Inter-network Connection

* If EC A or EC B is a non-NECA company, the application of their charges will depend upon EC A or EC B's access tariff.

7 · 24 · 02

Transmittal No. 933

8 · - 7 ·

Issued: ~~April 16, 2002~~

Effective: ~~May 1, 2002~~

ACCESS SERVICE

16. Public Packet Data Network (Cont'd)

16.1 Frame Relay Access Service (Cont'd)

16.1.2 Rate Regulations (Cont'd)

(A) Rate Categories (Cont'd)

Jointly-Provided Frame Relay Access Service

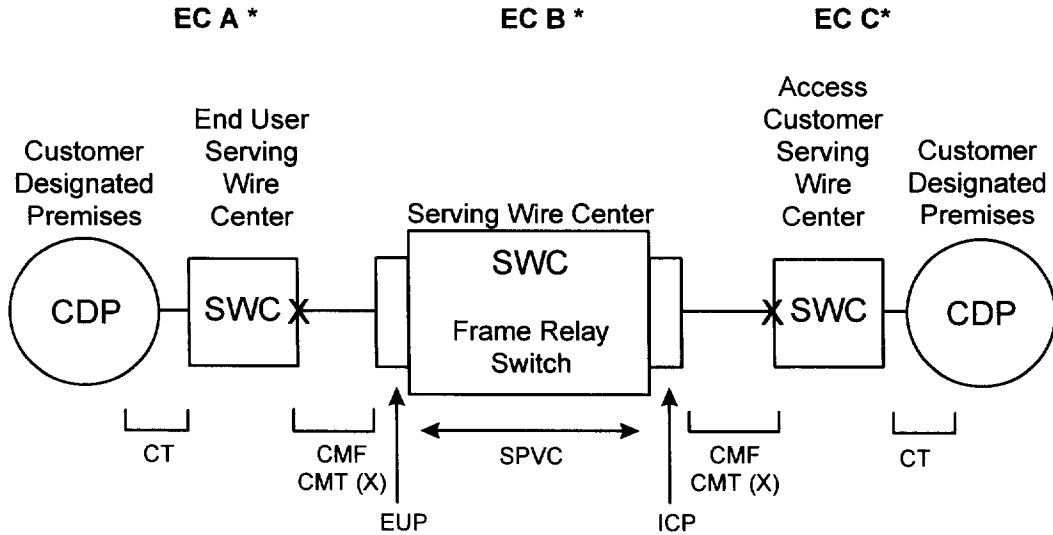

RATE ELEMENTS

	(Special Access Service)	(Frame Relay Access Service)
EC "A"	\$ CT = Channel Termination \$ CMT = Channel Mileage Termination \$ CMF = Channel Mileage Facility	
EC "B"	\$ CMF = Channel Mileage Facility \$ CMF = Channel Mileage Facility	\$ EUP = End User Port \$ SPVC = Standard Permanent Virtual Connection \$ ICP = Inter-network Customer Port
EC "C"	\$ CT = Channel Termination \$ CMT = Channel Mileage Termination \$ CMF = Channel Mileage Facility	

* If EC A, EC B or EC C is a non-NECA company, the application of their charges will depend upon EC A, EC B or EC C's access tariff.

(x) Issued to reflect new corporate address.

Transmittal No. 855

Issued: February 23, 2000

Effective: March 9, 2000

Director - Access Tariffs
 80 So. Jefferson Road, Whippany, NJ 07981

ACCESS SERVICE

(N)

16. Public Packet Data Network (Cont'd)

16.1 Frame Relay Access Service (Cont'd)

16.1.2 Rate Regulations (Cont'd)

(A) Rate Categories (Cont'd)

Interconnected FRAS Between Non-Adjacent Serving Territories

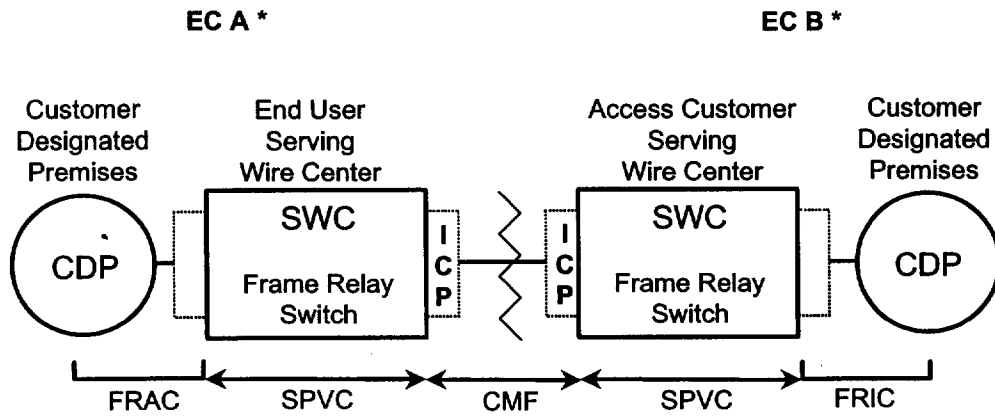

RATE ELEMENTS

	(Special Access Service)	(Frame Relay Access Service)
EC "A"-	CMF = Channel Mileage Facility	FRAC = Frame Relay Access Connection SPVC = Standard Permanent Virtual Connection ICP = Inter-network Customer Port
EC "B"-	CMF = Channel Mileage Facility	FRIC = Frame Relay Inter-network Connection SPVC = Standard Permanent Virtual Connection ICP = Inter-network Customer Port

* If EC A or EC B is a non-NECA company, the application of their charges will depend upon EC A or EC B's access tariff.

(N)

7 · 24 · 02

Transmittal No. 933

8 · - 7 · 02

Issued: ~~April 16, 2002~~

Effective: ~~May 1, 2002~~

Director - Access Tariffs
80 So. Jefferson Road, Whippany, NJ 07981

ACCESS SERVICE

16. Public Packet Data Network (Cont'd)16.1 Frame Relay Access Service (Cont'd)16.1.2 Rate Regulations (Cont'd)(A) Rate Categories (Cont'd)(1) Frame Relay Access Connection

The Frame Relay Access Connection (FRAC) rate element recovers the costs associated with the communication path between the end user's premises and the Telephone Company wire center equipped with a frame relay switch. The FRAC includes the physical transmission facility between the customer designated premises and the customer's serving wire center, the interoffice transport (if applicable) between the customer's serving wire center and a wire center equipped with a frame relay switch, and the end user port on the Telephone Company's frame relay switch.

One FRAC charge applies per customer designated premises at which the FRAS connection is terminated. This applies even if the customer designated premises and the frame relay switch are collocated in a Telephone Company building.

(2) Frame Relay Inter-network Connection

The Frame Relay Inter-network Connection (FRIC) rate element recovers the costs associated with the communication path between the access customer's premises and the Telephone Company wire center equipped with a frame relay switch. The FRIC includes the physical transmission facility between the customer designated premises and the customer's serving wire center, the interoffice transport (if applicable) between the customer's serving wire center and a wire center equipped with a frame relay switch, and the inter-network customer port on the Telephone Company's frame relay switch.

One FRIC charge applies per customer designated premises at which the FRAS connection is terminated. This applies even if the customer designated premises and the frame relay switch are collocated in a Telephone Company building.

(x) Issued to reflect new corporate address.

Transmittal No. 855

Issued: February 23, 2000

Effective: March 9, 2000

Director - Access Tariffs
80 So. Jefferson Road, Whippany, NJ 07981

ACCESS SERVICE

16. Public Packet Data Network (Cont'd)16.1 Frame Relay Access Service (Cont'd)16.1.2 Rate Regulations (Cont'd)(A) Rate Categories (Cont'd)(3) End User Port

An End User Port charge is applied as a discrete rate element in conjunction with jointly-provided Special Access Service. Refer to 7.9 and 7.10 preceding for additional applicable rates and charges.

The End User Port is the physical location in the Telephone Company switching office where the transport facility of the customer connects to the FRAS Network. It specifies how a frame relay switch sends and receives data from a frame relay end user customer's LAN or other compatible CPE devices.

The End User Port consists of either a 56.0 kbps, 64.0 kbps, 1.544 Mbps or 44.736 Mbps interface. The port connecting the transport facility to the Telephone Company frame relay switch must be ordered and provided at the same speed as the associated transport facility.

(x) Issued to reflect new corporate address.

Transmittal No. 855

Issued: February 23, 2000

Effective: March 9, 2000

Director - Access Tariffs
80 So. Jefferson Road, Whippany, NJ 07981

ACCESS SERVICE

16. Public Packet Data Network (Cont'd)

16.1 Frame Relay Access Service (Cont'd)

16.1.2 Rate Regulations (Cont'd)

(A) Rate Categories (Cont'd)

(4) Inter-network Customer Port

An Inter-network Customer Port Charge is applied in conjunction with Jointly-Provided FRAS and Interconnected FRAS between non-adjacent serving territories. Refer to Section 7.10, preceding for additional applicable rates and charges for the High Capacity Special Access Service used in conjunction with these services.

(C)
|
(C)

The Inter-network Customer Port is the physical location in the Telephone Company switching office where the access customer's transport facility connects to the Telephone Company's FRAS network. It specifies how a frame relay switch sends and receives data from a frame relay access customer's network.

The Inter-network Customer Port is offered at speeds of 1.544 Mbps or 44.736 Mbps. The port connecting the transport facility to the Telephone Company frame relay switch must be ordered and provided at the same speed as the associated transport facility.

7 · 24 · 02

Transmittal No. 933

8 · - 7

Issued: ~~April 16, 2002~~

Effective: ~~May 1, 2002~~

Director - Access Tariffs
80 So. Jefferson Road, Whippany, NJ 07981

ACCESS SERVICE

16. Public Packet Data Network (Cont'd)

16.1 Frame Relay Access Service (Cont'd)

16.1.2 Rate Regulations (Cont'd)

(A) Rate Categories (Cont'd)

(5) Permanent Virtual Connection (PVC)

A PVC is a software defined communications path between two port connections or between a port connection and a DSL Access Service Connection Point.

Each PVC is provisioned with a customer selected Committed Information Rate. The CIR is a transmission speed specified by the customer. CIRs range from 8 kbps to 768 kbps. The Telephone Company will provide switch capacity to permit the customer to transmit information with guaranteed delivery at the specified CIR. The Telephone Company will permit customers to attempt to transmit beyond the specified CIR up to the actual throughput speed of the port with no guarantee of completion. Attempted transmissions above the actual throughput speed of the port will not be permitted.

(C)
|
(C)

Customers will be permitted to order multiple PVCs on a given port subject to switch limitations. Customers anticipating non-simultaneous transmission may order CIRs assigned to these multiple PVCs, the sum of which may theoretically exceed the actual throughput of the port. However, when simultaneous transmission of multiple PVCs occurs, the total of the transmission rate (CIRs) may not exceed the actual throughput of the port.

There are two types of PVCs available. The standard PVC establishes a communications path within the Telephone Company's frame relay network between two ports or between a port and a DSL Access Service Connection Point. The extended PVC establishes a communications path on two interconnected telephone companies' frame relay networks located in adjacent serving territories between two ports or between a port and a DSL Access Service Connection Point.

Transmittal No. 1060

Issued: February 14, 2005

Effective:

- 4 / 13 / 05

Director - Access Tariffs
80 So. Jefferson Road, Whippany, NJ 07981

ACCESS SERVICE

16. Public Packet Data Network (Cont'd)16.1 Frame Relay Access Service (Cont'd)16.1.2 Rate Regulations (Cont'd)(B) Types of Rates and Charges

There are two types of rates and charges. They are monthly rates and nonrecurring charges. The rates and charges are described as follows:

(1) Monthly Rates

Monthly rates are recurring rates that apply each month or fraction thereof that a FRAS is provided. For billing purposes, each month is considered to have 30 days.

(2) Nonrecurring Charges

Nonrecurring charges are one-time charges that apply for specific work activity (i.e., installation or change to an existing service). The types of nonrecurring charges that apply for FRAS are: installation of service and service rearrangements. These charges are in addition to the Access Order Charge as specified in 17.4.1 following:

(a) Installation of Service

Nonrecurring charges apply for the installation of Frame Relay Access Connections (FRAC), Frame Relay Inter-network Connections (FRIC), and Permanent Virtual Connections (PVC).

A nonrecurring charge applies per FRAC or FRIC installed and is based on the speed of the connection.

A nonrecurring charge applies per PVC installed.

(x) Issued to reflect new corporate address.

Transmittal No. 855

Issued: February 23, 2000

Effective: March 9, 2000

Director - Access Tariffs
80 So. Jefferson Road, Whippany, NJ 07981

ACCESS SERVICE

16. Public Packet Data Network (Cont'd)16.1 Frame Relay Access Service (Cont'd)16.1.2 Rate Regulations (Cont'd)(B) Types of Rates and Charges (Cont'd)(2) Nonrecurring Charges (Cont'd)(b) Service Rearrangements

Service Rearrangements are changes to existing (installed) services.

A PVC Rearrangement Charge will be applied whenever a change is made to the CIR of an existing PVC after initial port installation and/or a change is made to the terminating port destination of the PVC.

Administrative changes will be made without charge(s) to the customer. Administrative changes are as follows:

- Change of customer name,
- Change of customer or customer's end user premises address when the change of address is not a result of physical relocation of equipment,
- Change in billing data (name, address, or contact name or telephone number),
- Change of agency authorization,
- Change of customer circuit identification,
- Change of billing account number,
- Change of customer or customer's end user contact name or telephone number, and
- Change of jurisdiction.

(c) Moves

A move involves a change in the physical location of one of the following:

- The Point of Termination at the customer's premises
- The customer's premises

(x) Issued to reflect new corporate address.

Transmittal No. 855

Issued: February 23, 2000

Effective: March 9, 2000

Director - Access Tariffs
80 So. Jefferson Road, Whippany, NJ 07981

ACCESS SERVICE

16. Public Packet Data Network (Cont'd)16.1 Frame Relay Access Service (Cont'd)16.1.2 Rate Regulations (Cont'd)(c) Moves (Cont'd)

The charges for the move are dependent on whether the move is to a new location within the same building or to a different building.

(i) Moves Within the Same Building

When the move is to a new location within the same building, the charge for the move will be an amount equal to one half of the nonrecurring (i.e., installation) charge for the service termination affected. There will be no change in the minimum period requirements. This charge is in addition to the Access Order Charge as specified in 17.4.1 following.

(ii) Moves To a Different Building

Moves to a different building will be treated as a discontinuance and start of service and all associated nonrecurring charges will apply. New minimum period requirements will be established for the new services. The customer will also remain responsible for satisfying all outstanding minimum period charges for the discontinued service.

(C) Minimum Period

The minimum period for FRAS is one month and the full monthly rate will apply to the first month. Adjustments for quantities of services established or discontinued in any billing period beyond the minimum period are as set forth in 2.4.1(F) preceding.

The minimum period for discounted FRAS is twelve months as set forth in 2.4.2 and 5.5.1 preceding.

(x) Issued to reflect new corporate address.

Transmittal No. 855

Issued: February 23, 2000

Effective: March 9, 2000

Director - Access Tariffs
80 So. Jefferson Road, Whippany, NJ 07981

ACCESS SERVICE

16. Public Packet Data Network (Cont'd)16.1 Frame Relay Access Service (Cont'd)16.1.3 Optional Rate Plans

A Term Discount plan is available for Frame Relay Access Service (FRAS). The Term Discount applies to the Frame Relay Access Connection and Frame Relay Inter-network Connection charges. The End User Port and Inter-network Customer Port charges are eligible for term discounts where the associated Special Access Service facility is eligible for a Special Access Service Term Discount. The conditions under which End User Port and Inter-network Customer Port Term Discounts apply are specified in 7.2.8(A)(1) preceding while the Term Discount percentage is as set forth in 17.4.8(A)(5) following. The Permanent Virtual Connections (PVC) are not eligible for a Term Discount. Under the Term Discount plan, the current monthly rates for eligible services are reduced by a fixed percentage. The amount of the discount percentage differs based on the length of the service commitment period selected by the customer. The Term Discount percentages for FRAS are as set forth in 17.4.8(A)(5) following.

Discounts for the Term Discount plan are only applied to FRAS provided to a customer within the same state and LATA by the same Telephone Company.

The Term Discount Optional Rate Plan is only available from those Telephone Companies listed in 17.3.10(A)(1) following.

The minimum service period on a month-to-month basis is one month. Under an Optional Rate Plan, the minimum service period is twelve months.

Certain material formerly found on this page now appears on Original Page 16-12.1.

Transmittal No. 1220

Issued: September 16, 2008

Effective: *December 18, 2008*

Director - Access Tariffs
80 So. Jefferson Road, Whippany, NJ 07981

ACCESS SERVICE

16. Public Packet Data Network (Cont'd)

16.1 Frame Relay Access Service (Cont'd)

16.1.3 Optional Rate Plans (Cont'd)

(A) Term Discounts

FRAS may be ordered at the customer's option on a month-to-month basis or for Term Discount periods of 36 months (3 years) or 60 months (5 years).

The minimum service period for all Term Discount plans is twelve months. The customer must specify the length of the service commitment period at the time the service is ordered.

For customers that subscribe to the Term Discount plan for 36 or 60 months, the Term Discount percentage as set forth in 17.4.8(A)(5) following will be frozen from Company initiated decreases for the entire discount period at the percent in effect at the beginning of the Term Discount period.

(N)

(N)

(M)

(M)

Certain material currently found on this page previously appeared on 1st Revised Page 16-12.

Transmittal No. 1220

Issued: September 16, 2008

Effective: *December 18, 2008*

Director - Access Tariffs
80 So. Jefferson Road, Whippany, NJ 07981

ACCESS SERVICE

16. Public Packet Data Network (Cont'd)16.1 Frame Relay Access Service (Cont'd)16.1.3 Optional Rate Plans (Cont'd)(A) Term Discounts (Cont'd)

If a Term Discount Percentage increase occurs during the term of an existing Term Discount plan, the increased percentage will be applied automatically to the remainder of the current Term Discount period.

At the end of the Term Discount period, the customer may convert to month-to-month service or subscribe to a new Term Discount plan. If the customer does not make a choice by the end of the discount period, the rates will automatically convert to month-to-month service rates.

To be included in a Term Discount plan, all eligible FRAS rate elements must be ordered for the same commitment term (i.e., all 36 months or all 60 months) and with the same service date. When additional capacity is subsequently added, it will be available only on a month-to-month basis unless the discount period of the entire service is upgraded.

Eligible FRAS rate elements are those provided to a customer within the same state and LATA by the same Telephone Company. As long as the number of FRAS connections included in a Term Discount plan remains constant, customer requests to install and disconnect FRAS connections, including changes affecting different wire centers and/or customer designated premises, will not change the current Term Discount period or the minimum service period, and Discontinuance of Service charges as set forth in (3) following will not apply.

Certain material formerly found on this page now appears on Original Page 16-13.1.

Transmittal No. 1220

Issued: September 16, 2008

Effective:

December 18, 2008

Director - Access Tariffs
80 So. Jefferson Road, Whippany, NJ 07981

ACCESS SERVICE

16. Public Packet Data Network (Cont'd)

16.1 Frame Relay Access Service (Cont'd)

16.1.3 Optional Rate Plans (Cont'd)

(A) Term Discounts (Cont'd)

(1) Upgrades in Term Discounts

Services provided under month-to-month rates or Term Discount rates may be upgraded to a Term Discount plan at any time without incurring FRAS nonrecurring charges or discontinuance charges for existing services. The new Term Discount plan must meet or exceed the service term of the plan being upgraded. For example, a service with a 36 month commitment period may be upgraded to a new 36 month or 60 month service period. The monthly rates will be those that are in effect at the time the service is upgraded. A new minimum service period applies to all FRAS that is upgraded.

(N)

(N)

(M)

(M)

Certain material currently found on this page previously appeared on 1st Revised Page 16-13.

Transmittal No. 1220

Issued: September 16, 2008

Effective: *December 18, 2008*

Director - Access Tariffs
80 So. Jefferson Road, Whippany, NJ 07981

ACCESS SERVICE

16. Public Packet Data Network (Cont'd)16.1 Frame Relay Access Service (Cont'd)16.1.3 Optional Rate Plans (Cont'd)(A) Term Discounts (Cont'd)(2) Upgrades in Capacity

If the customer chooses to upgrade a service under the Term Discount plan to a higher capacity (e.g., from 56.0 kbps to 64.0 kbps or from 56.0 kbps or 64.0 kbps to 1.544 Mbps), discontinuance charges will not apply, provided all the following conditions are met:

- the customer's order for the disconnect of the existing service and the installation of the new service are received at the same time and specifically reference the application of upgrade in capacity,
- the customer's disconnect order for the existing service must reference the service installation order,
- the new service has a total capacity greater than the total capacity of the service being discontinued and,
- the new Term Discount period meets or exceeds the Term Discount period being discontinued.

A new minimum service period applies to all upgrades. A Frame Relay Access Connection nonrecurring charge for an equivalent capacity of the existing services being upgraded to the higher speed service will not be assessed. FRAC nonrecurring charges will not apply to the upgraded lower speed services placed on the higher speed service if requested at the same time as the upgrade request. Nonrecurring charges will apply for capacity that exceeds the existing equivalent capacity.

(x) Issued to reflect new corporate address.

Transmittal No. 855

Issued: February 23, 2000

Effective: March 9, 2000

Director - Access Tariffs
80 So. Jefferson Road, Whippany, NJ 07981

ACCESS SERVICE

16. Public Packet Data Network (Cont'd)

16.1 Frame Relay Access Service (Cont'd)

16.1.3 Optional Rate Plans (Cont'd)

(A) Term Discounts (Cont'd)

(2) Upgrades in Capacity (Cont'd)

Discontinuance charges will not apply should the customer choose to upgrade either a portion of or the entire FRAS under the Term Discount plan and move the service to a new customer location(s) within the same state and LATA where service is provided by the same Telephone Company.

(3) Discontinuance of Service

If the customer chooses to disconnect all or a portion of the service prior to the expiration of the Term Discount period, discontinuance charges will apply to the portion of the service being discontinued.

Should the customer choose to discontinue a Term Discount plan prior to the completion of the Optional Rate Plan (ORP) minimum service period, discontinuance charges will apply. (C)
 Discontinuance charges equal to one-hundred percent of the total undiscounted monthly rates, less any amounts previously paid, will apply for the ORP minimum service period. Additionally, (C)
 discontinuance charges of fifteen percent of the total undiscounted monthly charges will apply to the remaining portion of the unsatisfied term (C)
 commitment period. (C)

For a 36 month (3 year) term commitment, the unsatisfied term commitment period is 24 months (36 months minus the 12 month ORP minimum service period). For a 60 month (5 year) term commitment, the unsatisfied term commitment period is 48 months (60 months minus the 12 month ORP minimum service period). For example, a customer chooses to discontinue a 1.544 Mbps (N)

Certain material previously found on this page now appears on Original Page 16-15.1.

Transmittal No. 1539

Issued: February 14, 2018

Effective: March 1, 2018

Director - Access Tariffs
 80 So. Jefferson Road, Whippany, NJ 07981

ACCESS SERVICE

16. Public Packet Data Network (Cont'd)

16.1 Frame Relay Access Service (Cont'd)

16.1.3 Optional Rate Plans (Cont'd)

(A) Term Discounts (Cont'd)

(3) Discontinuance of Service (Cont'd)

Frame Relay Access Connection in month 10 of a 36 month term commitment period. The discontinuance charges for disconnecting prior to the completion of the ORP minimum service period and before the end of the term commitment period would be:

(the undiscounted 1.544 Mbps monthly rates)
x (12)-(10 months payment received)

plus

(.15) x (24 months) x (the undiscounted
1.544 Mbps monthly rates)

Should the customer choose to discontinue service ordered under a Term Discount plan after the ORP minimum service period but before the completion of the discount period, discontinuance charges will apply. Discontinuance charges of fifteen percent of the total undiscounted monthly charges will apply to the remaining portion of the discount period. For example, a customer has a 1.544 Mbps Frame Relay Access Connection which it chooses to discontinue after 33 months into a 60-month service term. The discontinuance charge would be 0.15 times 27 months times the undiscounted monthly rates for that service.

(N)

(N)

(M)

(C)

(M)

Certain material currently found on this page previously appeared on 1st Revised Page 16-15.

Transmittal No. 1539

Issued: February 14, 2018

Effective: March 1, 2018

Director - Access Tariffs
80 So. Jefferson Road, Whippany, NJ 07981

ACCESS SERVICE

APPROVED

(N)

16. Public Packet Data Network (Cont'd)16.2 Asynchronous Transfer Mode Cell Relay Access Service16.2.1 General

Asynchronous Transfer Mode Cell Relay Access Service (ATM-CRS) is a connection-oriented transport service that is based on Asynchronous Transfer Mode (ATM) technology using fixed length, 53-byte cells. ATM cells generated by ATM-compatible customer premises equipment (CPE) are transmitted through the Telephone Company's ATM-CRS network to a pre-specified destination.

ATM-CRS provides customers requiring high-speed data transport for bandwidth intensive data, voice or video applications with the ability to interconnect multiple locations using the Telephone Company's ATM-CRS network. The customer may use ATM-CRS to interconnect its customer designated premises (CDPs) served by the Telephone Company's ATM-CRS network, to interconnect its local area network (LAN) to the Telephone Company's ATM-CRS network and/or to interconnect its CDPs to an ATM network located outside of the Telephone Company's serving territory.

16.2.2 Service Description

ATM-CRS is provided using a combination of Ports, Virtual Paths and Virtual Circuit Channels. An ATM-CRS Port is required to provide the interface into the Telephone Company's ATM-CRS network. A Virtual Path (VP) is required to establish a transmission path between any two ATM-CRS Ports. Virtual Circuit Channels (VCCs) may be ordered from the Telephone Company to establish a communications path between any two CDPs or established by the customer using its own equipment.

Service is provided, where available, between CDPs and designated Telephone Company Serving Wire Centers (SWCs). ATM-CRS will be furnished where suitable facilities exist as determined by the Telephone Company. The Telephone Company will identify its ATM-CRS equipped Serving Wire Centers in the NATIONAL EXCHANGE CARRIER ASSOCIATION, INC. Tariff F.C.C. No. 4.

(N)

Transmittal No. 930

Issued: ~~March 18, 2002~~Effective: ~~April 2, 2002~~

Director - Access Tariffs
80 So. Jefferson Road, Whippany, NJ 07981

5 - 15 - 02

ACCESS SERVICE

16. Public Packet Data Network (Cont'd)16.2 Asynchronous Transfer Mode Cell Relay Access Service (Cont'd)16.2.2 Service Description (Cont'd)

Rates and charges for ATM-CRS are specified in Section 17.4.8(B), following. The Telephone Company specific rate band assignment for the ATM-CRS rate elements is specified in the Special Access (SPA) column in Section 17.5.1, following. The application of rates and charges for ATM-CRS is described later in this section. (T)

16.2.3 Obligations of the Customer

In addition to the regulations described in other sections of this tariff, the following provisions apply to ATM-CRS:

- (A) The customer is responsible for providing the Telephone Company with the necessary information to provision ATM-CRS as specified in Section 5.2 Ordering Requirements, preceding.
- (B) The customer is responsible for providing and maintaining all required customer premises equipment (CPE), which is compatible with ATM-CRS and complies with the standards specified in the following publications: The ATM Forum Technical Committee ATM User-Network Interface (UNI) Signalling Specification (Version 4.0), Private Network-Network Interface Specification (Version 1.0) and BISDN Inter Carrier Interface (B-ICI) Specification (Version 2.0). A customer ordering Ethernet-based ATM-CRS Ports is also responsible for ensuring that its CPE complies with the standards specified in Technical Reference IEEE Std. 802.3-2008, Part 3, Section 1, Clause 15 for 10BASE-F, Section 2, Clause 26 for 100BASE-F, and Section 3, Clauses 34 through 38 for 1000BASE-X connections. A customer ordering the ATM-CRS Port Internet Protocol (IP) Function is also responsible for ensuring that its CPE hands off IP packets to the Telephone Company's ATM-CRS network in a format that complies with the standards specified in the Internet Engineering Task Force Request For Comments (RFC) 791 entitled "INTERNET PROTOCOL, DARPA Internet Program Protocol Specification" (September 1981) and RFC 1483 entitled "Multiprotocol Encapsulation over ATM Adaptation Layer 5" (July 1993).

Transmittal No. 1337

Issued: March 16, 2012

Effective: March 31, 2012

Director - Access Tariffs
80 So. Jefferson Road, Whippany, NJ 07981

ACCESS SERVICE

16. Public Packet Data Network (Cont'd)

16.2 Asynchronous Transfer Mode Cell Relay Access Service (Cont'd)

16.2.4 Rate Regulations

(T)

This section contains the regulations governing the rates and charges that apply for ATM-CRS. Regulations governing the rates and charges for Special, ADSL and/or SDSL Access Services provided under this tariff used in conjunction with ATM-CRS are as specified in Sections 7 and 8, preceding.

(M)

(M)

The following diagrams depict generic views of the components of ATM-CRS. In the first figure, all of the customer's CDPs are served by ATM-CRS equipped SWCs. The ATM-CRS customer orders the applicable ATM-CRS components pursuant to the provisions specified in this section and the applicable Special Access Service components pursuant to the provisions specified in Section 7, preceding.

Figure 1

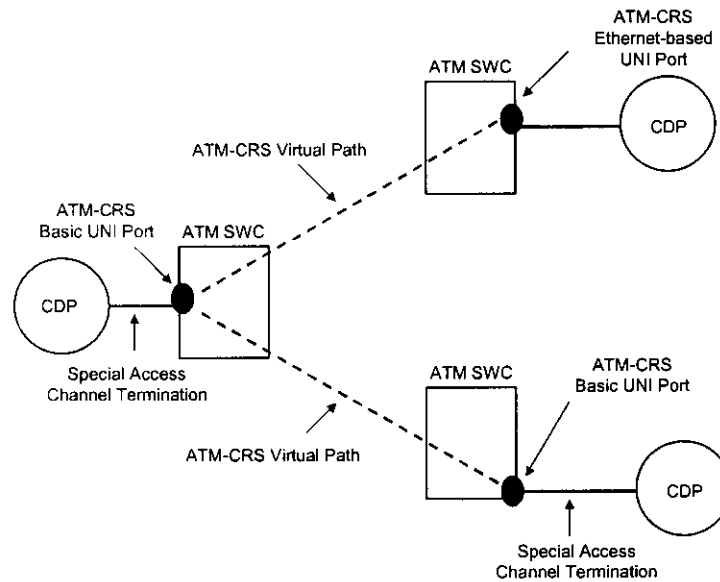

Certain material currently found on this page previously appeared on 1st Revised Page 16-17.

Transmittal No. 1192

Issued: December 17, 2007

Effective:

3 / 13

Director - Access Tariffs
 80 So. Jefferson Road, Whippany, NJ 07981

ACCESS SERVICE

16. Public Packet Data Network (Cont'd)

16.2 Asynchronous Transfer Mode Cell Relay Access Service (Cont'd)

16.2.4 Rate Regulations (Cont'd)

In the third figure, one of the customer's CDPs is served by another telephone company's ATM network. The ATM-CRS customer orders the applicable ATM-CRS components from the Telephone Company pursuant to the provisions specified in this section and the applicable Special Access Service components pursuant to the provisions specified in Section 7, preceding. In addition, the customer will order the applicable ATM and special access services components from the distant telephone company.

Figure 3

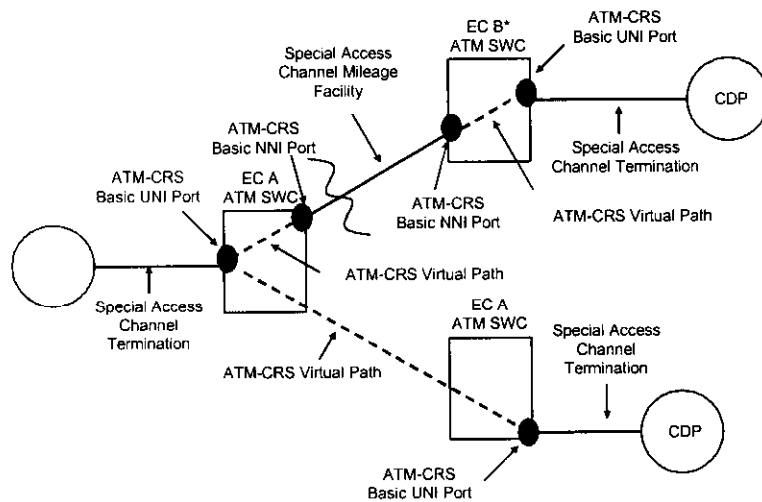

(T)

* IF ECB is a non-NECA company, the application of charges will depend on its access tariff.

Transmittal No. 1192

Issued: December 17, 2007

Effective:

Director - Access Tariffs
 80 So. Jefferson Road, Whippany, NJ 07981

3.3

ACCESS SERVICE

APPROVED (N)

16. Public Packet Data Network (Cont'd)

16.2 Asynchronous Transfer Mode Cell Relay Access Service (Cont'd)

16.2.4 Rate Regulations (Cont'd)

(A) Rate Categories

The various ATM-CRS service components are described below.

(1) ATM-CRS Ports

An ATM-CRS Port receives ATM cells from the customer's ATM-compatible CPE, validates the addressing parameters contained in the cell headers, and transmits the cells into the ATM-CRS network. The ATM-CRS Port also receives ATM cells from the Telephone Company's ATM-CRS network or from an ATM network located outside of the Telephone Company's serving territory, validates the addressing parameters contained in the cell headers, and transmits the cells to the pre-designated CDP.

ATM-CRS Ports are available with a User Network Interface (UNI) or a Network to Network Interface (NNI) as described below. Each ATM-CRS Port must be associated with a minimum of one ATM-CRS Virtual Path or DSL Access Service Connection optional function.

Interconnection of the Telephone Company's ATM-CRS network to another ATM network located outside of the Telephone Company's serving territory is provided using ATM-CRS Basic NNI ports and Telephone Company provided Special Access Services.

(a) Basic User Network Interface (UNI) Port

Basic UNI Ports provide a port only interface to the Telephone Company's ATM-CRS network and do not include the required transport facility between the CDP and the Telephone Company's SWC at which the basic UNI

(N)

Transmittal No. 930

Issued: ~~March 18, 2002~~

Effective: ~~April 2, 2002~~

Director - Access Tariffs
80 So. Jefferson Road, Whippany, NJ 07981

5 - 15 - 02

ACCESS SERVICE

APPROVED

(N)

16. Public Packet Data Network (Cont'd)

16.2 Asynchronous Transfer Mode Cell Relay Access Service (Cont'd)

16.2.4 (A) Rate Categories (Cont'd)

(1) ATM-CRS Ports (Cont'd)

(a) Basic User Network Interface (UNI) Port (Cont'd)

Port is located. Transport to connect the CDP with the basic UNI Port is provided using Telephone Company provided DS1 or DS3 High Capacity and/or OC3 or OC12 Synchronous Optical Channel Special Access Services as described in Sections 7.10 and 7.11, preceding. Basic UNI Ports are available at bandwidth speeds of 1.544 Mbps, 44.736 Mbps, 155.52 Mbps and 622.08 Mbps.

(b) Ethernet-based User Network Interface (UNI) Port

Ethernet-based UNI Ports are used to interconnect the customer's Ethernet-compatible CPE with the Telephone Company's ATM-CRS network and include the transport facility between the CDP and the Telephone Company's SWC, provided that the CDP is served by the SWC in which the Ethernet-based UNI Port is located. Ethernet-based UNI Ports are available at bandwidth speeds of up to 10 Mbps (i.e., 10BASE-F), up to 100 Mbps (i.e., 100BASE-F) and up to 1 Gbps (i.e., 1000BASE-X).

(c) Basic Network to Network Interface (NNI) Port

Basic NNI Ports provide a port only interface to the Telephone Company's ATM-CRS network and do not include the required transport facility between the CDP and the Telephone Company's SWC at which the basic NNI Port is located. Transport to connect the CDP with the basic NNI Port is provided using Telephone

(N)

Transmittal No. 930

Issued: ~~March 18, 2002~~

Effective: ~~April 2, 2002~~

ACCESS SERVICE

APPROVED

(N)

16. Public Packet Data Network (Cont'd)

16.2 Asynchronous Transfer Mode Cell Relay Access Service (Cont'd)

16.2.4 (A) Rate Categories (Cont'd)

(1) ATM-CRS Ports (Cont'd)

(c) Basic Network to Network Interface (NNI) Port (Cont'd)

Company provided DS1 or DS3 High Capacity and/or OC3 or OC12 Synchronous Optical Channel Special Access Services as described in Sections 7.10 and 7.11, preceding. Basic NNI Ports are available at bandwidth speeds of 1.544 Mbps, 44.736 Mbps, 155.52 Mbps and 622.08 Mbps.

(d) Ethernet-based Network to Network Interface (NNI) Port

Ethernet-based NNI Ports are used to interconnect the customer's Ethernet-compatible CPE with the Telephone Company's ATM-CRS network and include a fiber only connection between the CDP and the Telephone Company's SWC, provided that the CDP is served by the SWC in which the Ethernet-based NNI Port is located. Ethernet-based NNI Ports are available at bandwidth speeds of up to 10 Mbps (i.e., 10BASE-F), up to 100 Mbps (i.e., 100BASE-F) and up to 1 Gbps (i.e., 1000BASE-X)

Monthly and nonrecurring charges apply for each ATM-CRS Port ordered.

(N)

Transmittal No. 930

Issued: ~~March 18, 2002~~

Effective: ~~April 2, 2002~~

Director - Access Tariffs
80 So. Jefferson Road, Whippany, NJ 07981

5 - 15 - 02

APPROVED

(N)

ACCESS SERVICE

16. Public Packet Data Network (Cont'd)

16.2 Asynchronous Transfer Mode Cell Relay Access Service (Cont'd)

16.2.4 (A) Rate Categories (Cont'd)

(2) ATM-CRS Virtual Paths

An ATM-CRS Virtual Path (VP) is a pre-defined, logical circuit established by the Telephone Company that is required to route ATM cells between any two ATM-CRS Ports located within the Telephone Company's ATM-CRS network. VPs may be established between two ATM-CRS UNI Ports, between an ATM-CRS UNI Port and an ATM-CRS NNI Port, or between two ATM-CRS NNI Ports. VPs are available in increments of 1 Mbps. The bandwidth capacity on a VP may not exceed the maximum bandwidth of the associated ATM-CRS Ports. In addition to specifying the bandwidth capacity required on its order, the customer must specify one of the following traffic routing prioritization parameters for each VP ordered.

(a) Constant Bit Rate (CBR)

CBR supports applications that require special network timing and minimal delay to ensure steady data flow of user information through the ATM-CRS network. Examples of applications requiring CBR include voice, some types of video and circuit emulation for higher speed special access services. CBR is the highest priority traffic on the network.

(b) Variable Bit Rate - real time (VBR-rt)

VBR-rt supports applications for which the data flow is bursty and requires low delay variance in ATM cell transmissions. Examples of applications requiring VBR-rt include voice and video.

(N)

Transmittal No. 930

Issued: ~~March 18, 2002~~

Effective: ~~April 2, 2002~~

Director - Access Tariffs
80 So. Jefferson Road, Whippany, NJ 07981

5 - 15 - 02

ACCESS SERVICE

16. Public Packet Data Network (Cont'd)16.2 Asynchronous Transfer Mode Cell Relay Access Service (Cont'd)16.2.4 (A) Rate Categories (Cont'd)(2) ATM-CRS Virtual Paths (Cont'd)(c) Variable Bit Rate - non real time
(VBR-nrt)

VBR-nrt supports applications for which the data flow is bursty and variable delays in ATM cell transmissions can be tolerated. Examples of applications requiring VBR-nrt include file transfer, multimedia and computer aided design/computer aided manufacturing (CAD/CAM).

(d) Unspecified Bit Rate (UBR)

UBR supports applications for which the data flow is bursty and delay tolerant using "best effort" engineering. The Telephone Company will attempt to deliver all ATM cells received on a UBR VP, however, network congestion may result in a loss of ATM cells. Examples of applications requiring UBR include interactive data sessions, file transfers, monitoring and signaling.

Monthly and nonrecurring charges apply for each VP ordered. The monthly recurring charge is comprised of a fixed path charge and a variable bandwidth capacity charge, which is calculated based on the total bandwidth of the VP. For example assuming a Special Access (SPA) rate band assignment of 3, the monthly charge for a single 145 Mbps VBR-rt path would equal \$1,715.83 (\$3.38 fixed plus \$11.81 per Megabit).

(T)

Transmittal No. 1337

Issued: March 16, 2012

Effective: March 31, 2012

Director - Access Tariffs
80 So. Jefferson Road, Whippany, NJ 07981

ACCESS SERVICE

16. Public Packet Data Network (Cont'd)

16.2 Asynchronous Transfer Mode Cell Relay Access Service (Cont'd)

16.2.4 (A) Rate Categories (Cont'd)

(3) ATM-CRS Virtual Circuit Channels (VCCs)

An ATM-CRS Virtual Circuit Channel (VCC) is a pre-defined logical circuit used to route ATM cells between any two CDPs served by the Telephone Company's ATM-CRS network. VCCs may be established by the customer using its CPE or by the Telephone Company in its ATM-CRS network via the service order process.

Monthly and nonrecurring charges apply for each VCC ordered by the customer. Rates and charges specified in Section 17.4.8(B)(3), following, do not apply to VCCs established by the customer.

(4) Optional Features and Functions

(a) DSL Access Service Connection

Where available, ATM-CRS UNI and/or NNI Ports may be equipped with the DSL Access Service Connection function. This function provides for the interconnection of ATM-CRS with ADSL Access Service as described in Section 8.1, preceding, and with SDSL Access Service as described in Section 8.2, preceding, provided by the Telephone Company under this tariff. The function also provides for the interconnection of ATM-CRS with a wireline broadband Internet transmission service provided on a non-tariffed, common carrier basis. This optional function allows the ATM-CRS customer to receive ADSL, SDSL, and/or wireline broadband Internet transmission service data traffic from and transmit ADSL, SDSL, and/or wireline broadband Internet transmission service data traffic to

(C)
(C)

Transmittal No. 1222

Issued: September 30, 2008

Effective: *December 18, 2008*

ACCESS SERVICE

16. Public Packet Data Network (Cont'd)

16.2 Asynchronous Transfer Mode Cell Relay Access Service (Cont'd)

16.2.4 (A) Rate Categories (Cont'd)

(4) Optional Features and Functions (Cont'd)

(a) DSL Access Service Connection (Cont'd)

its end user customers using a UBR traffic routing prioritization parameter.

It is available only at Telephone Company designated DSL Access Service Connection Point SWCs located within the Telephone Company's serving territory or in the serving territory of another telephone company. The speed of the DSL Access Service Connection function ordered by the customer may not exceed the speed of the associated ATM-CRS Port.

Transmittal No. 1434

Issued: October 23, 2014

Effective: November 7, 2014

Director - Access Tariffs
80 So. Jefferson Road, Whippany, NJ 07981

ACCESS SERVICE

APPROVED

16. Public Packet Data Network (Cont'd)

16.2 Asynchronous Transfer Mode Cell Relay Access Service (Cont'd)

16.2.4 (A) Rate Categories (Cont'd)

(4) Optional Features and Functions (Cont'd)

(a) DSL Access Service Connection (Cont'd)

A nonrecurring charge applies per port to equip the ATM-CRS UNI or NNI Port with the DSL Access Service Connection function.

- (i) A customer that requires a VBR-nrt traffic routing prioritization parameter may also order a DSL VCC between its CDP and the premises of its end user customer, provided such end user customer's premises is equipped with ADSL and/or SDSL Access Service provided by the Telephone Company under this tariff as described in Sections 8.1 and 8.2, preceding. Each DSL VCC is available with a maximum bandwidth capacity of 1 Mbps, however, the maximum speed to or from the ADSL and/or SDSL Access Service customer will not exceed the maximum peak speeds for the services as specified in Sections 8.1 and 8.2, preceding. The customer is responsible for specifying in its order the premises locations and number of DSL VCCs it wants established to each of its end user customers. Monthly and nonrecurring charges apply to each DSL VCC established by the Telephone Company. The DSL VCC charges apply in addition to the nonrecurring charge for equipping the ATM-CRS UNI or NNI Port with the DSL Access Service Connection function.

(C)
|
(C)

Transmittal No. 1110

Issued: January 27, 2006

Effective:

Director - Access Tariffs

3 / 29 / 06

80 So. Jefferson Road, Whippany, NJ 07981

ACCESS SERVICE

16. Public Packet Data Network (Cont'd)16.2 Asynchronous Transfer Mode Cell Relay Access Service (Cont'd)16.2.4 (A) Rate Categories (Cont'd)(4) Optional Features and Functions (Cont'd)(a) DSL Access Service Connection (Cont'd)

- (ii) Where suitable facilities exist, a customer that requires the ability to send high speed multimedia transmissions may also order a MultiMedia VCC (MM-VCC) between its CDP and the premises of its end user customer, provided such end user customer's premises is equipped with ADSL Access Service provided by the Telephone Company under this tariff as described in Section 8.1, preceding. The MM-VCC is available in increments of 1 Mbps, or 4 Mbps. The customer is responsible for specifying in its order the premises locations and the capacity of each MM-VCC. Transmission speed across the MM-VCC is not guaranteed and may be affected by factors that affect the actual speeds delivered, including the ADSL Access Service customer's distance from the Telephone Company Serving Wire Center, condition of the facilities, and any capacity limitations in the ATM-CRS customer's network design. Monthly and nonrecurring charges apply to each MM-VCC established by the Telephone Company. The MM-VCC charges apply in addition to the nonrecurring charge for equipping the ATM-CRS UNI or NNI Port with the DSL Access Service Connection function.

(C)

Transmittal No. 1117

Issued: March 17, 2006

Effective:

Director - Access Tariffs
80 So. Jefferson Road, Whippany, NJ 07981

16-27-06

ACCESS SERVICE

16. Public Packet Data Network (Cont'd)

16.2 Asynchronous Transfer Mode Cell Relay Access Service (Cont'd)

16.2.4 (A) Rate Categories (Cont'd)

(4) Optional Features and Functions (Cont'd)

(a) DSL Access Service Connection
(Cont'd)

(ii) (Cont'd)

When a customer elects to change the bandwidth capacity of an existing MM-VCC or to remove an existing MM-VCC from an associated ADSL Access Service line, the MM-VCC nonrecurring charge specified in Section 17.4.8(B) (4) (a) (iv), will not apply. In lieu of such charge, the MM-VCC Design Change Charge will apply, as specified in Section 16.2.4 (B) (2) (d), following.

When a customer disconnects a MM-VCC and the associated ADSL Access Service line at the same time, neither the MM-VCC nonrecurring charge or MM-VCC Design Change Charge will apply.

APPROVED

(N)

(N)

Certain material formerly found on this page now appears on Original Page 16-27.1.2.

Transmittal No. 1117

Issued: March 17, 2006

Effective:

Director - Access Tariffs
80 So. Jefferson Road, Whippany, NJ 07981

5

ACCESS SERVICE

16. Public Packet Data Network (Cont'd)

16.2 Asynchronous Transfer Mode Cell Relay Access Service (Cont'd)

16.2.4 (A) Rate Categories (Cont'd)

(4) Optional Features and Functions (Cont'd)

(b) ATM-CRS Port Internet Protocol (IP) Function

Where available, ATM-CRS UNI and/or NNI Ports may be equipped with the ATM-CRS Port Internet Protocol (IP) Function. This non-chargeable optional function allows the customer to transmit IP packets, which were formatted by the customer's CPE in conformance with the standards specified in the Internet Engineering Task Force Request For Comments (RFC) 791 entitled "INTERNET PROTOCOL, DARPA Internet Program Protocol Specification" (September 1981) and RFC 1483 entitled "Multiprotocol Encapsulation over ATM Adaptation Layer 5" (July 1993), through the Telephone Company's ATM-CRS network. Monthly and nonrecurring charges do not apply to the ATM-CRS Port IP Function. When this function is installed subsequent to the installation of the ATM-CRS Port or removed from an existing ATM-CRS Port, an Access Order Charge as specified in Section 17.4.1, following, will apply per order.

(N)

(N)

(M)

(M)

Certain material currently found on this page formerly appeared on Original Page 16-27.1.1.

Transmittal No. 1117

Issued: March 17, 2006

Effective: A

Director - Access Tariffs
80 So. Jefferson Road, Whippany, NJ 07981

ACCESS SERVICE

16. Public Packet Data Network (Cont'd)

16.2 Asynchronous Transfer Mode Cell Relay Access Service (Cont'd)

16.2.4 Rate Regulations (Cont'd)

(B) Types of Rates and Charges

There are two types of rates and charges. They are monthly rates and nonrecurring charges. The rates and charges are described below:

(1) Monthly Rates

Monthly rates are recurring rates that apply each month or fraction thereof that an ATM-CRS service component is provided. For billing purposes, each month is considered to have 30 days.

(N)

(N)

(M)

(M)

Certain material currently found on this page formerly appeared on Original Page 16-27.

Transmittal No. 977

Issued: March 17, 2003

Effective: April 1, 2003

Director - Access Tariffs
80 So. Jefferson Road, Whippany, NJ 07981

ACCESS SERVICE

16. Public Packet Data Network (Cont'd)

16.2 Asynchronous Transfer Mode Cell Relay Access Service (Cont'd)

16.2.4 (B) Types of Rates and Charges (Cont'd)

(2) Nonrecurring Charges

APPROVED

Nonrecurring charges are one-time charges that apply for specific work activity (i.e., installation or change to an existing service). The types of nonrecurring charges that apply for ATM-CRS are installation of service, service rearrangements, moves and MM-VCC Design Changes. Except as specified below, these charges are in addition to the Access Order Charge as specified in Section 17.4.1, following.

(C)
|
(C)

(a) Installation of Service

Nonrecurring charges apply for installation of Ports, VPs, VCCs, and Optional Features and Functions ordered by the customer.

(b) Service Rearrangements

Service rearrangements are changes to existing (i.e., installed) services, which may be administrative only in nature as set forth below or, that involve an actual physical change to the service.

The VP nonrecurring charge will apply per VP to change the bandwidth capacity and/or to change the traffic routing prioritization parameter on an existing VP.

Transmittal No. 1117

Issued: March 17, 2006

Effective:

Director - Access Tariffs
80 So. Jefferson Road, Whippany, NJ 07981

1/9/06 43

ACCESS SERVICE

APPROVED

(N)

16. Public Packet Data Network (Cont'd)

16.2 Asynchronous Transfer Mode Cell Relay Access Service (Cont'd)

16.2.4 (B) Types of Rates and Charges (Cont'd)

(2) Nonrecurring Charges (Cont'd)

(b) Service Rearrangements (Cont'd)

Administrative changes will be made without charge(s) to the customer. Administrative changes are as follows:

- Change of customer name,
- Change of customer or customer's end user premises address when the change of address is not a result of physical relocation of equipment,
- Change in billing data (name, address, or contact name or telephone number),
- Change of agency authorization,
- Change of customer circuit identification,
- Change of billing account number,
- Change of customer or customer's end user contact name or telephone number, and
- Change of jurisdiction

(c) Moves

A move involves a change in the physical location of one of the following:

- The Point of Termination at the customer's premises
- The customer's premises

(N)

Transmittal No. 930

Issued: ~~March 18, 2002~~

Effective: ~~April 2, 2002~~

Director - Access Tariffs
80 So. Jefferson Road, Whippany, NJ 07981

5 - 15 - 2

ACCESS SERVICE

APPROVED

(N)

16. Public Packet Data Network (Cont'd)

16.2 Asynchronous Transfer Mode Cell Relay Access Service (Cont'd)

16.2.4 (B) Types of Rates and Charges (Cont'd)

(2) Nonrecurring Charges (Cont'd)

(c) Moves (Cont'd)

The charges for moving ATM-CRS service components are dependent on whether the move is to a different location within the same building, to a different building within the same SWC, or to a different building in a different SWC. The charges specified below apply in addition to any applicable charges for moving the associated Special Access Services as specified in Section 7.2.3, preceding.

(i) Moves Within the Same Building

Port only interfaces (i.e., Basic UNI/NNI Ports), VPs and VCCs are not impacted when a customer moves its Point of Termination to a different location within the same building. The charge for moving an Ethernet-based UNI or Ethernet-based NNI Port within the same building will be an amount equal to one half of the nonrecurring (i.e., installation) charge for the port. There will be no change in the minimum period requirements.

(ii) Moves To a Different Building Within the Same SWC

Port only interfaces (i.e., Basic UNI/NNI Ports), VPs and VCCs are not impacted when a customer moves its Point of Termination to a different building within the same SWC. The move of an Ethernet-based UNI or Ethernet-based NNI Port will be treated as a

(N)

Transmittal No. 930

Issued: ~~March 18, 2002~~

Effective: ~~April 2, 2002~~

ACCESS SERVICE

16. Public Packet Data Network (Cont'd)

16.2 Asynchronous Transfer Mode Cell Relay Access Service (Cont'd)

16.2.4 (B) Types of Rates and Charges (Cont'd)

(2) Nonrecurring Charges (Cont'd)

(d) MM-VCC Design Changes

The MM-VCC Design Change Charge specified in Section 17.4.8(B) (4) (a) (v), following, will apply per MM-VCC, when the customer elects to change the bandwidth capacity of an existing MM-VCC or to remove an existing MM-VCC from an associated ADSL Access Service line. Access Order Charges will not apply when MM-VCC Design Change Charges are applicable.

(C) Minimum Periods

The minimum period for ATM-CRS service components provided to a customer and for which charges are applicable are:

- Twelve months for ATM-CRS Ports
- One month for ATM-CRS Virtual Paths and Virtual Circuit Channels

When a customer replaces its existing ATM-CRS service with a new Ethernet Transport Service provided pursuant to Section 16.3, following, the Telephone Company will waive any unsatisfied minimum period charges that may otherwise be applicable.

(N)
|
(N)

Transmittal No. 1157

Issued: February 2, 2007

Effective:

5 0 7 7

Director - Access Tariffs
80 So. Jefferson Road, Whippany, NJ 07981

ACCESS SERVICE

APPROVED

(N)

16. Public Packet Data Network (Cont'd)

16.2 Asynchronous Transfer Mode Cell Relay Access Service (Cont'd)

16.2.4 (B) Types of Rates and Charges (Cont'd)

(2) Nonrecurring Charges (Cont'd)

(c) Moves (Cont'd)

(ii) Moves To a Different Building Within the Same SWC (Cont'd)

discontinuance and start of service. Associated nonrecurring (i.e., installation) charges will apply. New minimum period requirements will be established for the new services. The customer will also remain responsible for satisfying all outstanding minimum period charges for the discontinued service.

(iii) Moves to a Different Building in a Different SWC

A move to a different building in a different SWC will be treated as a discontinuance and start of service of all associated ATM-CRS service components. Associated nonrecurring (i.e., installation) charges will apply. New minimum period requirements will be established for the new services. The customer will also remain responsible for satisfying all outstanding minimum period charges for the discontinued service.

(N)

Transmittal No. 930

Issued: ~~March 18, 2002~~

Effective: ~~April 2, 2002~~

Director - Access Tariffs
80 So. Jefferson Road, Whippany, NJ 07981

5 · 1 5 · 0 2

ACCESS SERVICE

(N)

16. Public Packet Data Network (Cont'd)16.2 Asynchronous Transfer Mode Cell Relay Access Service (Cont'd)16.2.5 ATM-CRS Term Discount Plan

An optional term discount plan is available for Asynchronous Transfer Mode Cell Relay Access Service (ATM-CRS). Under the ATM-CRS Term Discount Plan, the monthly rates for eligible ATM-CRS service elements are reduced by a fixed percentage. The amount of the discount percentage differs based on the length of the term commitment period selected by the ATM-CRS customer.

ATM-CRS may be ordered at the customer's option on a month-to-month basis or, under a single term commitment period of either 36 months or 60 months. The customer must notify the Telephone Company in writing of the length of its selected term commitment period. For purposes of this plan, all ATM-CRS Basic User Network Interface (UNI), ATM-CRS Basic Network to Network Interface (NNI), ATM-CRS Ethernet-based UNI and ATM-CRS Ethernet-based NNI Ports included in a customer's ATM-CRS Term Discount Plan are referred to as committed ATM-CRS Ports. To be included in an ATM-CRS Term Discount Plan, all committed ATM-CRS Ports must be ordered for the same term commitment period (i.e., all 36 months or all 60 months) and remain in-service at the same bandwidth capacity throughout the entire term commitment period. ATM-CRS Ports installed after the establishment of the customer's ATM-CRS Term Discount Plan may be ordered on a month-to-month basis or added as additional committed ATM-CRS Ports to a customer's existing term commitment period as described in (A), below.

Access Order Charges as described in Section 5.4.1, preceding, do not apply to establish a new or make any changes to an existing ATM-CRS Term Discount Plan.

(N)

Transmittal No. 1202

Issued: March 17, 2008

Effective: *July 10, 2008*Director - Access Tariffs
80 So. Jefferson Road, Whippany, NJ 07981

ACCESS SERVICE

(N)

16. Public Packet Data Network (Cont'd)16.2 Asynchronous Transfer Mode Cell Relay Access Service (Cont'd)16.2.5 ATM-CRS Term Discount Plan (Cont'd)

The monthly rates for ATM-CRS service elements are set forth in Section 17.4.8(B), following. The term discount percentages for the ATM-CRS Term Discount Plan are set forth in Section 17.4.8(B)(5), following. The ATM-CRS Term Discount Plan is only available from those Telephone Companies listed in Section 17.3.10(A)(1), following.

The term discount percentage for the customer's selected term commitment period applies to all committed ATM-CRS Ports provided within the Telephone Company's operating territory. The term discount percentage also applies to the following eligible ATM-CRS elements when these elements are provided within the Telephone Company's operating territory and associated with a committed ATM-CRS Port: 1) ATM-CRS Virtual Paths (VPs); 2) ATM-CRS Virtual Circuit Channels (VCCs); 3) ATM-CRS Digital Subscriber Line VCCs (DSL VCCs); and 4) ATM-CRS MultiMedia VCCs (MM-VCCs). Since there are no bandwidth or in-service requirements for ATM-CRS VPs, ATM-CRS VCCs, ATM-CRS DSL VCCs and ATM-CRS MM-VCCs associated with committed ATM-CRS Ports under the ATM-CRS Term Discount Plan, customer ordered disconnects of or changes to the number or bandwidth capacities for these elements do not affect the customer's ATM-CRS Term Discount Plan.

The term discount percentage does not apply to: 1) ATM-CRS Ports ordered on a month-to-month basis; 2) ATM-CRS VPs, ATM-CRS VCCs, ATM-CRS DSL VCCs and ATM-CRS MM-VCCs that are not associated with a committed ATM-CRS Port; 3) ATM-CRS nonrecurring charges; and 4) special access services connected to an ATM-CRS Port.

(N)

Transmittal No. 1202

Issued: March 17, 2008

Effective: *July 10, 2008*Director - Access Tariffs
80 So. Jefferson Road, Whippany, NJ 07981

ACCESS SERVICE

16. Public Packet Data Network (Cont'd)16.2 Asynchronous Transfer Mode Cell Relay Access Service (Cont'd)16.2.5 ATM-CRS Term Discount Plan (Cont'd)

Except as specified in (A)-(C), below, discontinuance charges will apply when the customer fails to satisfy the term commitment period or the in-service requirements for its committed ATM-CRS Ports.

The term discount percentage set forth in Section 17.4.8(B)(5), following, will not be subject to Telephone Company initiated decreases during the customer's selected term commitment period.

If a term discount percentage increase occurs during the term of an existing ATM-CRS Term Discount Plan, the increased percentage will be applied automatically for the remainder of the customer's existing term commitment period.

At the end of the term commitment period, the customer may subscribe to a new ATM-CRS Term Discount Plan commitment period or revert to month-to-month rates. If the customer does not notify the Telephone Company in writing of its choice by the end of its existing term commitment period, the Telephone Company will automatically convert the customer's ATM-CRS billing to month-to-month rates. An Access Order Charge will not apply when a customer at the end of its existing term commitment period subscribes to a replacement ATM-CRS Term Discount Plan or reverts to month-to-month rates.

(T)

Transmittal No. 1302

Issued: March 8, 2011

Effective:

~~JUN 06 2011~~

Director - Access Tariffs
80 So. Jefferson Road, Whippany, NJ 07981

ACCESS SERVICE

(N)

16. Public Packet Data Network (Cont'd)16.2 Asynchronous Transfer Mode Cell Relay Access Service (Cont'd)16.2.5 ATM-CRS Term Discount Plan (Cont'd)(A) ATM-CRS Port Additions

An ATM-CRS Term Discount Plan customer will choose one of the following options when ordering a new ATM-CRS Port during its existing term commitment period:

- (1) Add the new ATM-CRS Port to its existing ATM-CRS Term Discount Plan provided: 1) the customer commits to retain the newly installed ATM-CRS Port in-service at the same bandwidth capacity for the remainder of the existing term commitment period and 2) the ATM-CRS Port is being added before the last year of an existing term commitment period. The term commitment period of the customer's existing ATM-CRS Term Discount Plan will continue uninterrupted. During the last year of the commitment period, ATM-CRS Ports may not be added to an existing term commitment period.
- (2) Order the new ATM-CRS Port on a month-to-month basis. No term discount percentage would apply to the newly installed ATM-CRS Port. The term commitment period of the customer's existing ATM-CRS Term Discount Plan will continue uninterrupted.
- (3) Replace the existing ATM-CRS Term Discount Plan in its entirety with a new ATM-CRS Term Discount Plan as described in (C), below.

(N)

Transmittal No. 1202

Issued: March 17, 2008

Effective: *July 10, 2008*

Director - Access Tariffs
80 So. Jefferson Road, Whippany, NJ 07981

ACCESS SERVICE

(N)

16. Public Packet Data Network (Cont'd)

16.2 Asynchronous Transfer Mode Cell Relay Access Service (Cont'd)

16.2.5 ATM-CRS Term Discount Plan (Cont'd)

(B) Committed ATM-CRS Port Replacements

- (1) An ATM-CRS Term Discount Plan customer may disconnect a committed ATM-CRS Port before the end of its existing term commitment period and replace it with one or more newly installed committed ATM-CRS Port(s) without the application of a discontinuance charge as described in (D), below, provided: 1) the bandwidth capacity of the replacement committed ATM-CRS Port(s) is equal to or greater than the bandwidth capacity of the disconnected committed ATM-CRS Port; 2) the customer commits to retain the replacement committed ATM-CRS Port(s) in-service at the same bandwidth capacity for the remainder of the existing term commitment period; 3) the replacement committed ATM-CRS Port(s) is added to the existing term commitment before the last year of an existing term commitment period; and 4) the customer's orders for the disconnection of the originally committed ATM-CRS Port and installation of the replacement committed ATM-CRS Port(s) are submitted to the Telephone Company at the same time and include cross references as described in Section 5.2.7, preceding.

(N)

Transmittal No. 1202

Issued: March 17, 2008

Effective: *July 10, 2008*

ACCESS SERVICE

(N)

16. Public Packet Data Network (Cont'd)16.2 Asynchronous Transfer Mode Cell Relay Access Service (Cont'd)16.2.5 ATM-CRS Term Discount Plan (Cont'd)(B) Committed ATM-CRS Port Replacements (Cont'd)

(2) If the bandwidth capacity of the newly installed committed ATM-CRS Port(s) is less than the bandwidth capacity of the disconnected committed ATM-CRS Port, the disconnected committed ATM-CRS Port will be subject to a discontinuance charge as described in (D), below. The newly installed port(s) can be added as a committed ATM-CRS Port to the existing term commitment period or ordered on a month-to-month basis as described in (A), above.

(3) Since newly installed ATM-CRS Ports cannot be added to an existing term commitment period during the last year of the commitment period, an existing committed ATM-CRS Port disconnected during the last year of the commitment period cannot be replaced as described in (B)(1), above. The disconnected committed ATM-CRS Port will be subject to a discontinuance charge as described in (D), below. During the last year of the term commitment period, newly installed ATM-CRS Ports can be ordered as described in (A), above.

(N)

Transmittal No. 1202

Issued: March 17, 2008

Effective: *July 10, 2008*Director - Access Tariffs
80 So. Jefferson Road, Whippany, NJ 07981

ACCESS SERVICE

(N)

16. Public Packet Data Network (Cont'd)16.2 Asynchronous Transfer Mode Cell Relay Access Service (Cont'd)16.2.5 ATM-CRS Term Discount Plan (Cont'd)(B) Committed ATM-CRS Port Replacements (Cont'd)

- (4) An ATM-CRS Term Discount Plan customer may disconnect a committed ATM-CRS Port before the end of its existing term commitment period and replace it with one or more newly installed committed ETS Port(s) added to the customer's existing ETS Term Discount Plan without the application of a discontinuance charge as described in (D), below, provided: 1) the bandwidth capacity of the replacement committed ETS Port(s) is equal to or greater than the bandwidth capacity of the disconnected committed ATM-CRS Port; 2) the term commitment period remaining in the customer's existing ETS Term Discount Plan meets or exceeds the number of months remaining in the customer's existing ATM-CRS Term Discount Plan; 3) the customer commits to retain the replacement committed ETS Port(s) in-service at the same bandwidth capacity for the remainder of the customer's existing ETS Term Discount Plan term commitment period; 4) the replacement committed ETS Port(s) is added to the customer's existing ETS Term Discount Plan term commitment before the last year of an existing term commitment period; and 5) the customer's orders for the disconnection of the originally committed ATM-CRS Port and installation of the replacement committed ETS Port(s) are submitted to the Telephone Company at the same time and include cross references as described in Section 5.2.7, preceding.

Terms and conditions for the ETS Term Discount Plan are specified in Section 16.3.5, following.

(N)

Transmittal No. 1202

Issued: March 17, 2008

Effective: July 10, 2008

Director - Access Tariffs
80 So. Jefferson Road, Whippany, NJ 07981

ACCESS SERVICE

(N)

16. Public Packet Data Network (Cont'd)

16.2 Asynchronous Transfer Mode Cell Relay Access Service (Cont'd)

16.2.5 ATM-CRS Term Discount Plan (Cont'd)

(C) ATM-CRS Term Discount Plan Replacements

- (1) The customer may replace an existing ATM-CRS Term Discount Plan in its entirety with a new ATM-CRS Term Discount Plan without the application of a discontinuance charge as described in (D), below, provided: 1) the term commitment period of the new ATM-CRS Term Discount Plan meets or exceeds the number of months remaining in the customer's existing ATM-CRS term commitment period and 2) the bandwidth capacity of the committed ATM-CRS Ports under the new ATM-CRS Term Discount Plan meets or exceeds the bandwidth capacity of the committed ATM-CRS Ports in the customer's existing ATM-CRS term commitment period. The term discount percentage applicable for the new ATM-CRS Term Discount Plan will apply on a going forward basis based on the customer's written request to establish a new ATM-CRS Term Discount Plan commitment period under this provision.

(N)

Transmittal No. 1202

Issued: March 17, 2008

Effective: *July 10, 2008*

Director - Access Tariffs
80 So. Jefferson Road, Whippany, NJ 07981

ACCESS SERVICE

(N)

16. Public Packet Data Network (Cont'd)

16.2 Asynchronous Transfer Mode Cell Relay Access Service (Cont'd)

16.2.5 ATM-CRS Term Discount Plan (Cont'd)

(C) ATM-CRS Term Discount Plan Replacements (Cont'd)

(1) (Cont'd)

For example, a customer with an existing 36 month term commitment period and 30 Mbps of bandwidth capacity for its committed ATM-CRS Ports can replace that term commitment in its entirety with a new 36 month or 60 month term commitment period at any time during the existing term commitment period without the application of a discontinuance charge provided the bandwidth capacity of the customer's committed ATM-CRS Ports under the new term commitment period is at least 30 Mbps.

- (2) When the term commitment period of a replacement ATM-CRS Term Discount Plan does not meet or exceed the number of months remaining in the customer's existing ATM-CRS Term Discount Plan commitment period, a discontinuance charge as described in (D), below, will apply.

(N)

Transmittal No. 1202

Issued: March 17, 2008

Effective: *July 10, 2008*

Director - Access Tariffs
80 So. Jefferson Road, Whippany, NJ 07981

ACCESS SERVICE

(N)

16. Public Packet Data Network (Cont'd)

16.2 Asynchronous Transfer Mode Cell Relay Access Service (Cont'd)

16.2.5 ATM-CRS Term Discount Plan (Cont'd)

(C) ATM-CRS Term Discount Plan Replacements (Cont'd)

(3) When the term commitment period of the new ATM-CRS Term Discount Plan meets or exceeds the number of months remaining in the customer's existing ATM-CRS term commitment period, but the bandwidth capacity of the customer's committed ATM-CRS Ports under the new term commitment period is less than the bandwidth capacity of the committed ATM-CRS Ports under the customer's existing term commitment period, the following provisions will apply.

(a) When the total monthly undiscounted charges for the number and type of committed ATM-CRS Ports to be included in the customer's replacement ATM-CRS Term Discount Plan is equal to or greater than the total monthly undiscounted charges for the number and type of committed ATM-CRS Ports included in the customer's existing ATM-CRS Term Discount Plan, the customer will be permitted to replace its existing ATM-CRS Term Discount Plan without the application of either a discontinuance charge as described in (D), below, or a commitment shortfall charge as described in (b), below.

(N)

Transmittal No. 1202

Issued: March 17, 2008

Effective: *July 10, 2008*

Director - Access Tariffs
80 So. Jefferson Road, Whippany, NJ 07981

ACCESS SERVICE

(N)

16. Public Packet Data Network (Cont'd)

16.2 Asynchronous Transfer Mode Cell Relay Access Service (Cont'd)

16.2.5 ATM-CRS Term Discount Plan (Cont'd)

(C) ATM-CRS Term Discount Plan Replacements (Cont'd)

(3) (Cont'd)

(b) When the total monthly undiscounted charges for the number and type of committed ATM-CRS Ports to be included in the customer's replacement ATM-CRS Term Discount Plan is less than the total monthly undiscounted charges for the number and type of committed ATM-CRS Ports included in the customer's existing ATM-CRS Term Discount Plan, the customer will be permitted to replace its existing ATM-CRS Term Discount Plan under this provision, however, a commitment shortfall charge will apply. The commitment shortfall charge will apply in lieu of a discontinuance charge as described in (D), below, and will be calculated as follows:

Step 1: Determine the difference between the total monthly undiscounted charges for the number and type of committed ATM-CRS Ports included in the customer's existing ATM-CRS Term Discount Plan and the total monthly undiscounted charges for the number and type of committed ATM-CRS Ports to be included in the customer's replacement ATM-CRS Term Discount Plan.

(N)

Transmittal No. 1202

Issued: March 17, 2008

Effective: *July 10, 2008*

ACCESS SERVICE

(N)

16. Public Packet Data Network (Cont'd)

16.2 Asynchronous Transfer Mode Cell Relay Access Service (Cont'd)

16.2.5 ATM-CRS Term Discount Plan (Cont'd)

(C) ATM-CRS Term Discount Plan Replacements (Cont'd)

(3)(b) (Cont'd)

Step 2: Multiply the result from Step 1 by 35%.

Step 3: Multiply the result from Step 2 times the number of months remaining in the existing term commitment period.

For example, a customer elects to replace its existing 36 month ATM-CRS Term Discount Plan in its entirety in the 30th month of the existing term commitment period with a new 36 month ATM-CRS Term Discount Plan. The existing term plan commitment includes a total bandwidth capacity requirement of 134.208 Mbps for the customer's three 44.736 Mbps committed ATM-CRS Basic UNI Ports. In the replacement ATM-CRS Term Discount Plan, the customer will only be including one 100 Mbps committed ATM-CRS Ethernet-based UNI Port. Although the customer satisfies the term commitment length replacement requirement with the new ATM-CRS Term Discount Plan, it does not satisfy the bandwidth capacity replacement requirement and the total monthly undiscounted charges under the new term commitment period are less than the total monthly undiscounted charges under the existing term commitment period.

(N)

Transmittal No. 1202

Issued: March 17, 2008

Effective: *July 10, 2008*

Director - Access Tariffs
80 So. Jefferson Road, Whippany, NJ 07981

ACCESS SERVICE

(N)

16. Public Packet Data Network (Cont'd)16.2 Asynchronous Transfer Mode Cell Relay Access Service (Cont'd)16.2.5 ATM-CRS Term Discount Plan (Cont'd)(C) ATM-CRS Term Discount Plan Replacements (Cont'd)

(3) (b) (Cont'd)

Using illustrative undiscounted monthly rates of \$2,485.16 for a 44.736 Mbps ATM-CRS Basic UNI Port and \$982.38 for a 100 Mbps ATM-CRS Ethernet-based UNI Port, the Telephone Company would bill the customer a commitment shortfall charge totaling \$13,593.54 based on:

Step 1: \$7,455.48 (i.e., \$2,485.16 x 3 ports) - \$982.38 = \$6,473.10
Step 2: \$6,473.10 x 35% = \$2,265.59
Step 3: \$2,265.59 x 6 months = \$13,593.54

- (4) The customer may replace an existing ATM-CRS Term Discount Plan in its entirety with a new ETS Term Discount Plan without the application of a discontinuance charge as described in (D), below, provided:
- 1) the term commitment period of the new ETS Term Discount Plan meets or exceeds the number of months remaining in the customer's existing ATM-CRS term commitment period and 2) the bandwidth capacity of the committed ETS Ports under the new ETS Term Discount Plan meets or exceeds the bandwidth capacity of the committed ATM-CRS Ports in the customer's existing ATM-CRS term commitment period. The term discount percentage applicable for the new ETS Term Discount Plan will apply on a going forward basis based on the customer's written request to establish a new ETS Term Discount Plan commitment period under this provision.

(N)

Transmittal No. 1202

Issued: March 17, 2008

Effective: *July 10, 2008*

Director - Access Tariffs
 80 So. Jefferson Road, Whippany, NJ 07981

ACCESS SERVICE

(N)

16. Public Packet Data Network (Cont'd)

16.2 Asynchronous Transfer Mode Cell Relay Access Service (Cont'd)

16.2.5 ATM-CRS Term Discount Plan (Cont'd)

(C) ATM-CRS Term Discount Plan Replacements (Cont'd)

(4) (Cont'd)

When the term commitment period of a replacement ETS Term Discount Plan does not meet or exceed the number of months remaining in the customer's existing ATM-CRS Term Discount Plan commitment period, a discontinuance charge as described in (D), below, will apply.

Terms and conditions for the ETS Term Discount Plan are specified in Section 16.3.5, following.

(D) Discontinuance Charges

Except as provided for in (B) and (C), above, discontinuance charges will apply when: 1) the customer disconnects a committed ATM-CRS Port prior to the end of the term commitment period; 2) the customer disconnects a committed ATM-CRS Port prior to the end of the term commitment period and the replacement committed ATM-CRS or ETS Port(s) does not satisfy the requirements specified in (B), above; 3) the customer discontinues an existing ATM-CRS Term Discount Plan in its entirety prior to the end of the term commitment period; or 4) the customer replaces an existing ATM-CRS Term Discount Plan with a new ATM-CRS Term Discount Plan or new ETS Term Discount Plan that does not satisfy the requirements specified in (C), above.

(N)

Transmittal No. 1202

Issued: March 17, 2008

Effective: July 10, 2008

ACCESS SERVICE

(N)

16. Public Packet Data Network (Cont'd)16.2 Asynchronous Transfer Mode Cell Relay Access Service (Cont'd)16.2.5 ATM-CRS Term Discount Plan (Cont'd)(D) Discontinuance Charges (Cont'd)

The discontinuance charge will be equal to 35% of the total undiscounted monthly rate for each committed ATM-CRS Port included in the customer's ATM-CRS Term Discount Plan for each month remaining in the unsatisfied term commitment period. Minimum service period charges as specified in Section 16.2.4(C), preceding, would also apply, if applicable.

The following examples illustrate how the Telephone Company will calculate the applicable discontinuance charge.

Example 1

A customer discontinues its existing ATM-CRS Term Discount Plan in its entirety in the 20th month of a 36 month term commitment period. The customer included three 100 Mbps committed ATM-CRS Ethernet-based UNI Ports when it established its initial term plan commitment.

Using an illustrative undiscounted monthly rate of \$982.38 for a 100 Mbps ATM-CRS Ethernet-based UNI Port, the Telephone Company would bill the customer a term plan discontinuance charge totaling \$16,503.84 (i.e., \$982.38 x 35% x 3 ports x 16 months).

(N)

Transmittal No. 1202

Issued: March 17, 2008

Effective: *July 10, 2008*

Director - Access Tariffs
80 So. Jefferson Road, Whippany, NJ 07981

ACCESS SERVICE

(N)

16. Public Packet Data Network (Cont'd)

16.2 Asynchronous Transfer Mode Cell Relay Access Service (Cont'd)

16.2.5 ATM-CRS Term Discount Plan (Cont'd)

(D) Discontinuance Charges (Cont'd)

Example 2

A customer disconnects one of the four 10 Mbps committed ATM-CRS Ethernet-based UNI Ports included in its ATM-CRS Term Discount Plan in the 39th month of a 60 month term commitment period. The customer included all four of these ports when it established its initial term plan commitment.

Using an illustrative undiscounted monthly rate of \$689.01 for a 10 Mbps ATM-CRS Ethernet-based UNI Port, the Telephone Company would bill the customer a port discontinuance charge totaling \$5,064.15 (i.e., \$689.01 x 35% x 21 months).

(N)

Transmittal No. 1202

Issued: March 17, 2008

Effective: *July 10, 2008*

Director - Access Tariffs
80 So. Jefferson Road, Whippany, NJ 07981

ACCESS SERVICE

16. Public Packet Data Network (Cont'd)16.3 Ethernet Transport Service16.3.1 General

Ethernet Transport Service (ETS) is a high speed data transport service that provides end-to-end transmission using Ethernet packet technology at transport speeds ranging from 2 Mbps to 400 Gbps, where available. ETS is ideal for transport of broadband multimedia traffic (i.e., voice, data and video) using variable length Ethernet packets with the ability to interconnect multiple locations using the Telephone Company's ETS network. Ethernet packets generated by Ethernet-compatible customer premises equipment (CPE) are transmitted using available capacity on shared transmission paths through the Telephone Company's ETS network to a pre-specified destination. The ETS customer may use ETS to: (1) interconnect customer designated premises (CDPs) served by the Telephone Company's ETS network, (2) interconnect with its local area network (LAN) to the Telephone Company's ETS network and/or (3) interconnect its CDPs to an Ethernet network located outside of the Telephone Company's serving territory. (C)

16.3.2 Service Description

ETS is provided using a combination of ETS Channel Terminations (ETS CTs), ETS Ports, ETS Ethernet Virtual Connections (ETS EVCs), ETS Extended Ethernet Virtual Connections (ETS E-EVCs) and ETS Interconnected Ethernet Virtual Connections (ETS I-EVCs). As described below, ETS may be used in conjunction with Special Access High Capacity DS3 and Synchronous Optical Channel Service OC3 and OC12 Services as specified in Section 7, preceding, and with DSL Access Services as specified in Section 8, preceding.

Transmittal No. 1676

Issued: October 17, 2022

Effective: November 1, 2022

Senior Director - Access Tariff Cost Development
60 Columbia Road, Bldg. A - 2nd Fl., Morristown, NJ 07960

ACCESS SERVICE

(N)

16. Public Packet Data Network (Cont'd)

16.3 Ethernet Transport Service (Cont'd)

16.3.2 Service Description (Cont'd)

(N)

An ETS Port is required to provide the interface into the Telephone Company's ETS network. ETS EVCs establish a shared transmission path between any two ETS Ports on the Telephone Company's ETS network. ETS E-EVCs may be ordered to connect the Telephone Company's ETS network to an adjacent telephone company's Ethernet network. ETS I-EVCs may be ordered to connect the Telephone Company's ETS network to a non-adjacent telephone company's Ethernet network as described in Section 16.3.4(A)(5), below.

(M)

(M)

(N)

(N)

Certain material currently found on this page previously appeared on Original Page 16-33.

Transmittal No. 1273

Issued: April 30, 2010

Effective:

August 18, 2010

Director - Access Tariffs
80 So. Jefferson Road, Whippany, NJ 07981

ACCESS SERVICE

16. Public Packet Data Network (Cont'd)16.3 Ethernet Transport Service16.3.2 Service Description (Cont'd)

The transmission quality of ETS is not guaranteed and is offered to ETS customers at a best effort level. The Telephone Company will attempt to deliver all Ethernet packets received; however, network congestion may result in a loss of Ethernet packets. Transmission speeds using copper facilities may be affected by distance from the Telephone Company central office and other technical limitations in the Telephone Company's copper network and are also not guaranteed.

Service is provided, where available, between CDPs and designated Telephone Company Serving Wire Centers (SWCs). ETS will be furnished where suitable facilities exist as determined by the Telephone Company. The Telephone Company will identify its ETS-equipped Serving Wire Centers (SWCs) in the NATIONAL EXCHANGE CARRIER ASSOCIATION, INC. Tariff F.C.C. No. 4.

Rates and charges for ETS are specified in Section 17.4.8(C), following. The Telephone Company specific rate band assignment for the ETS rate elements is specified in the Ethernet Transport Service (ETS) column in Section 17.5.1, following, or when applicable, as specified in Section 17.4.8(C)(9), following. The application of rates and charges for ETS is described later in this section. (C)

Transmittal No. 1418

Issued: April 16, 2014

Effective: May 1, 2014

Director - Access Tariffs
80 So. Jefferson Road, Whippany, NJ 07981

ACCESS SERVICE

16. Public Packet Data Network (Cont'd)

16.3 Ethernet Transport Service

16.3.3 Obligations of the Customer

In addition to the regulations described in other sections of this tariff, the following provisions apply to ETS:

- (A) The ETS customer is responsible for providing the Telephone Company with the necessary information to provision ETS as specified in Section 5.2 Ordering Requirements, preceding.
- (B) The ETS customer is responsible for providing and maintaining all required CPE, which is compatible with ETS and complies with the standards specified in Technical Reference IEEE Standard 802.3-2022, Part 3, Sections 1 through 5.

(T)

Transmittal No. 1675

Issued: October 17, 2022

Effective: November 1, 2022

Senior Director - Access Tariff Cost Development
60 Columbia Road, Bldg. A - 2nd Fl., Morristown, NJ 07960

ACCESS SERVICE

(N)

16. Public Packet Data Network (Cont'd)

16.3 Ethernet Transport Service (Cont'd)

16.3.4 Rate Regulations

This section contains the regulations governing the rates and charges that apply for ETS. Regulations governing the rates and charges for Special Access and DSL Access Services provided under this tariff used in conjunction with ETS are as specified in Sections 7 and 8, preceding.

The following diagrams depict generic views of the elements of ETS. In the first figure, the ETS customer's CDPs are served by a single ETS SWC. ETS EVCs ordered between two ETS Ports in the same SWC are classified as ETS Intraswitch EVCs. The ETS customer orders the applicable ETS elements from the Telephone Company pursuant to the provisions specified in this section.

Figure 1

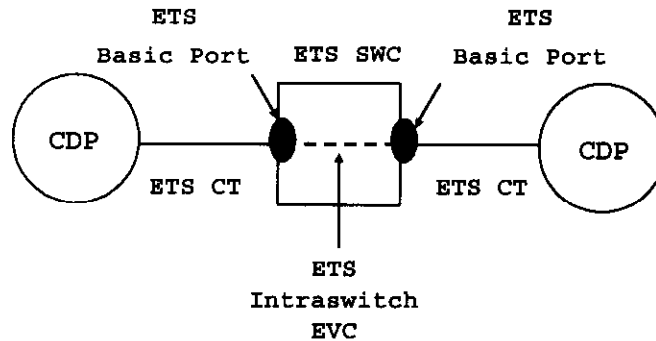

(N)

Transmittal No. 1157

Issued: February 2, 2007

Effective:

3/07/07

Director - Access Tariffs
80 So. Jefferson Road, Whippany, NJ 07981

ACCESS SERVICE

(N)

16. Public Packet Data Network (Cont'd)

16.3 Ethernet Transport Service (Cont'd)

16.3.4 Rate Regulations (Cont'd)

In the second figure, the ETS customer's CDPs are served by different ETS SWCs. ETS EVCs ordered between two ETS Ports in different SWCs are classified as ETS Interswitch EVCs. The ETS customer orders the applicable ETS elements from the Telephone Company pursuant to the provisions specified in this section.

Figure 2

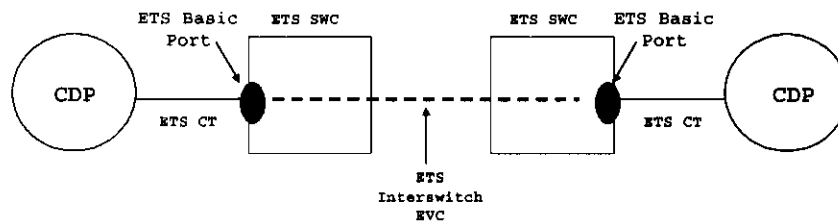

In the third figure, one of the ETS customer's CDPs is served by a non-ETS SWC. The ETS customer orders the applicable ETS elements from the Telephone Company pursuant to the provisions specified in this section and the applicable Special Access facilities pursuant to the provisions specified in Section 7, preceding.

Figure 3

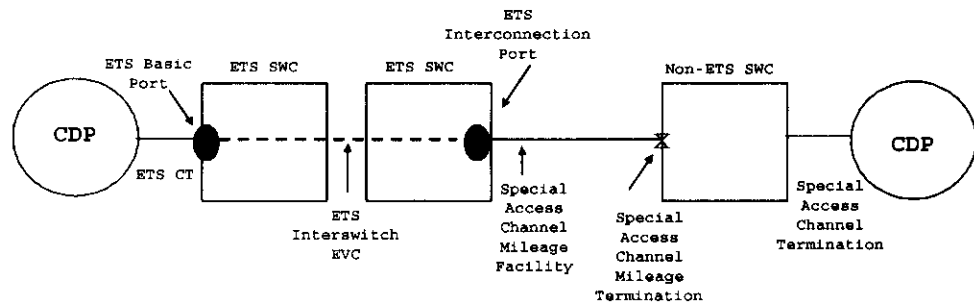

(N)

Transmittal No. 1157

Issued: February 2, 2007

Effective: 1

Director - Access Tariffs
80 So. Jefferson Road, Whippany, NJ 07981

ACCESS SERVICE

(N)

16. Public Packet Data Network (Cont'd)

16.3 Ethernet Transport Service (Cont'd)

16.3.4 Rate Regulations (Cont'd)

In the fourth figure, a multipoint configuration is depicted where the customer chose to order Special Access Service to an ETS SWC. The ETS customer orders the applicable ETS elements from the Telephone Company pursuant to the provisions specified in this section and the applicable Special Access facilities pursuant to the provisions specified in Section 7, preceding.

Figure 4

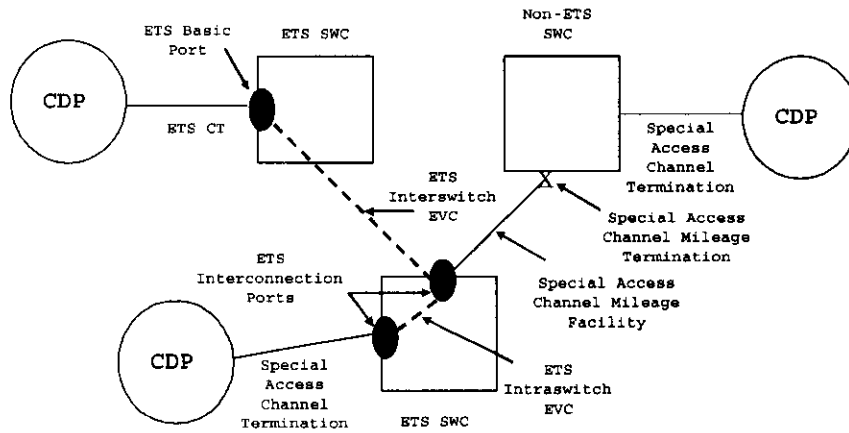

(N)

Transmittal No. 1157

Issued: February 2, 2007

Effective:

Director - Access Tariffs
80 So. Jefferson Road, Whippany, NJ 07981

ACCESS SERVICE

(N)

16. Public Packet Data Network (Cont'd)

16.3 Ethernet Transport Service (Cont'd)

16.3.4 Rate Regulations (Cont'd)

In the fifth figure, one of the ETS customer's CDPs is served by an adjacent telephone company's Ethernet network. The ETS customer orders the applicable ETS elements from the Telephone Company pursuant to the provisions specified in this section. In addition, the ETS customer will order the applicable Ethernet service elements from the adjacent telephone company.

Figure 5

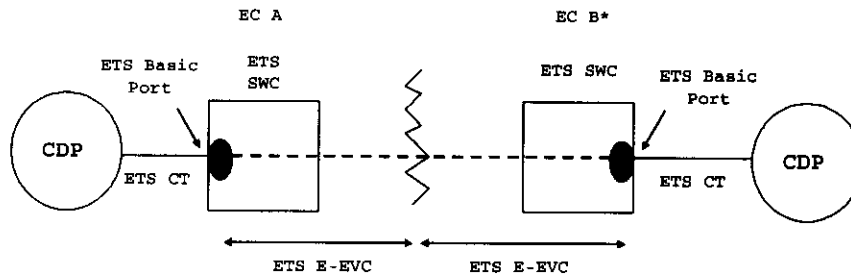

* If EC B is a non-NECA company, the application of charges will depend on its access tariff

(N)

Transmittal No. 1157

Issued: February 2, 2007

Effective:

Director - Access Tariffs
80 So. Jefferson Road, Whippany, NJ 07981

ACCESS SERVICE

16. Public Packet Data Network (Cont'd)

16.3 Ethernet Transport Service (Cont'd)

16.3.4 Rate Regulations (Cont'd)

In the sixth figure, one of the ETS customer's CDPs is served by a non-adjacent telephone company's Ethernet network. When the number of airline miles between the ETS SWCs serving the ETS customer's CDPs is greater than seventy-five, the ETS customer orders the applicable ETS elements from the Telephone Company pursuant to the provisions specified in this section and applicable Special Access facilities pursuant to the provisions specified in Section 7, preceding. In addition, the ETS customer will order the applicable special access service and Ethernet service elements from the interconnecting telephone companies.

(C)

Figure 6

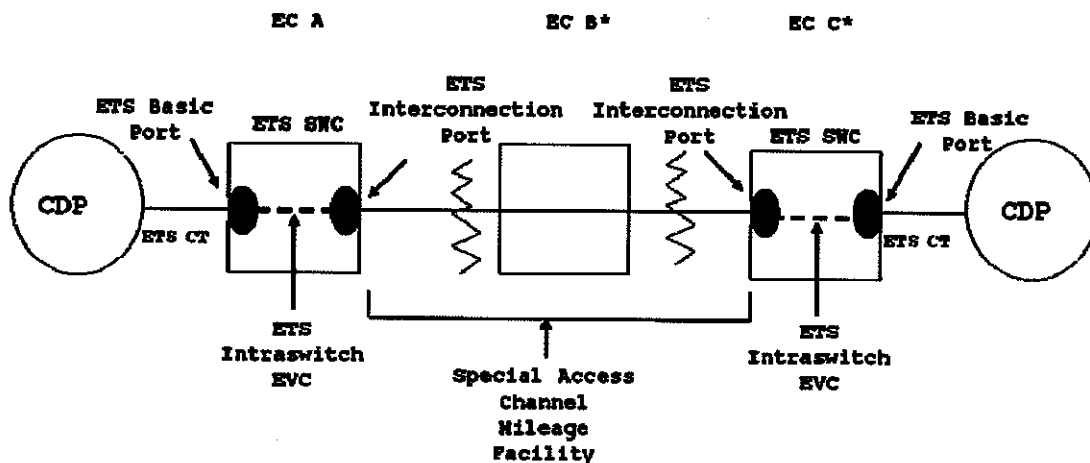

* If EC B and C are non-NECA companies, the application of charges will depend on their access tariffs.

Transmittal No. 1327

Issued: December 5, 2011

Effective: December 20, 2011

Director - Access Tariffs
 80 So. Jefferson Road, Whippany, NJ 07981

ACCESS SERVICE

16. Public Packet Data Network (Cont'd)

16.3 Ethernet Transport Service (Cont'd)

16.3.4 Rate Regulations (Cont'd)

In the seventh figure, one of the ETS customer's CDPs is served by a non-adjacent telephone company's Ethernet network. When the number of airline miles between the ETS SWCs serving the ETS customer's CDPs is equal to or less than seventy-five, the ETS customer orders the applicable ETS elements from the Telephone Company pursuant to the provisions specified in this section. In addition, the ETS customer will order the applicable Ethernet service elements from the non-adjacent telephone company.

(C)

Figure 7

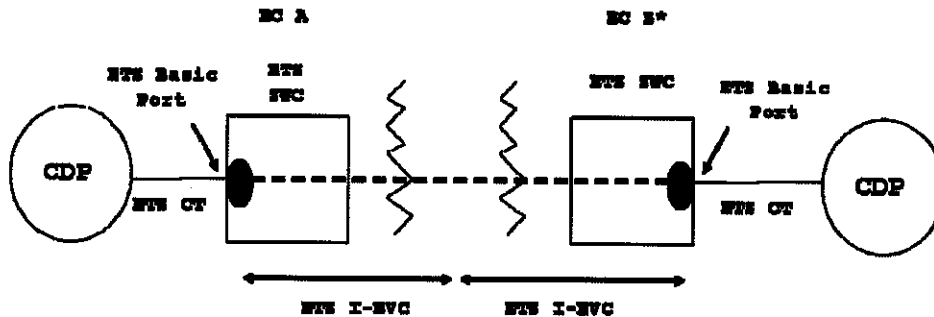

* If EC B is a non-NECA company, the application of charges will depend on its access tariff.

Transmittal No. 1327

Issued: December 5, 2011

Effective: December 20, 2011

Director - Access Tariffs
 80 So. Jefferson Road, Whippany, NJ 07981

ACCESS SERVICE

16. Public Packet Data Network (Cont'd)16.3 Ethernet Transport Service (Cont'd)16.3.4 Rate Regulations (Cont'd)(A) Rate Categories

The various ETS service elements are described below.

(1) ETS Channel Terminations (CTs)

An ETS CT provides the transport facility between the customer's designated premises and an ETS Basic Port at the Telephone Company's ETS SWC.

ETS CTs are available at bandwidth speeds of 2 Mbps, 5 Mbps, 10 Mbps, 20 Mbps, 50 Mbps, 100 Mbps, 200 Mbps, 250 Mbps, 300 Mbps, 400 Mbps, 500 Mbps, 600 Mbps, 700 Mbps, 750 Mbps, 800 Mbps, 900 Mbps, 1 Gbps, 2.5 Gbps, 5 Gbps, 10 Gbps, 50 Gbps, 100 Gbps, 200 Gbps, and 400 Gbps. The ETS customer orders the type of ETS CT it needs based on its bandwidth requirements. Bandwidth speeds of 50 Mbps and above require use of a fiber loop facility, where such fiber facilities exist. ETS CTs are available only from suitably equipped ETS SWCs for connection to ETS Basic Ports. (C) (C)

A Special Access High Capacity DS3 or Synchronous Optical Channel Service OC3 or OC12 Channel Termination may also be used to connect a CDP to the Telephone Company's ETS SWC for connection to an ETS Interconnection Port. The provisions for Special Access Channel Terminations are specified in Section 7, preceding.

Transmittal No. 1676

Issued: October 17, 2022

Effective: November 1, 2022

Senior Director - Access Tariff Cost Development
60 Columbia Road, Bldg. A - 2nd Fl., Morristown, NJ 07960

ACCESS SERVICE

16. Public Packet Data Network (Cont'd)

16.3 Ethernet Transport Service (Cont'd)

16.3.4 Rate Regulations (Cont'd)

(A) Rate Categories (Cont'd)

(1) ETS Channel Terminations (CTs) (Cont'd)

Monthly and nonrecurring charges apply for each ETS CT ordered. The monthly recurring rate and nonrecurring charge are based upon the bandwidth capacity ordered and whether the CDP is located within 300 feet of the ETS SWC or more than 300 feet from the ETS SWC. Rates and charges are specified in Section 17.4.8(C)(1), following, or when applicable, as specified in Section 17.4.8(C)(9), following. The Telephone Company specific rate band assignment for the ETS Channel Termination rate element is specified in the Ethernet Transport Service (ETS) column in Section 17.5.1, following, or when applicable, in Section 17.4.8(C)(9), following.

(C)
(C)

Transmittal No. 1418

Issued: April 16, 2014

Effective: May 1, 2014

Director - Access Tariffs
80 So. Jefferson Road, Whippany, NJ 07981

ACCESS SERVICE

(N)

16. Public Packet Data Network (Cont'd)

16.3 Ethernet Transport Service (Cont'd)

16.3.4 Rate Regulations (Cont'd)

(A) Rate Categories (Cont'd)

(2) ETS Ports

ETS Ports provide the interface at the Telephone Company's ETS SWC for data traffic to and from the customer premises equipment as well as for connecting the Telephone Company's ETS network with the Ethernet network of another telephone company. An ETS Port receives Ethernet packets from the ETS customer's Ethernet-compatible CPE, validates the addressing parameters contained in the packet headers, and transmits the packets into the ETS network. The ETS Port also receives Ethernet packets from the Telephone Company's ETS network or from an Ethernet network located outside of the Telephone Company's serving territory, validates the addressing parameters contained in the packet headers, and transmits the packets to the pre-designated CDP.

There are two types of ETS Ports available, i.e., ETS Basic Ports and ETS Interconnection Ports.

(N)

Transmittal No. 1157

Issued: February 2, 2007

Effective:

Director - Access Tariffs
80 So. Jefferson Road, Whippany, NJ 07981

3 / 0 7 7

ACCESS SERVICE

16. Public Packet Data Network (Cont'd)16.3 Ethernet Transport Service (Cont'd)16.3.4 Rate Regulations (Cont'd)(A) Rate Categories (Cont'd)(2) ETS Ports (Cont'd)

(a) ETS Basic Ports provide the interface to the Telephone Company's ETS network and do not include the required transport facility between the CDP and the Telephone Company's ETS SWC.

ETS Basic Ports are available with bandwidth speeds of 2 Mbps, 5 Mbps, 10 Mbps, 20 Mbps, 50 Mbps, 100 Mbps, 200 Mbps, 250 Mbps, 300 Mbps, 400 Mbps, 500 Mbps, 600 Mbps, 700 Mbps, 750 Mbps, 800 Mbps, 900 Mbps, 1 Gbps, 2.5 Gbps, 5 Gbps, 10 Gbps, 50 Gbps, 100 Gbps, 200 Gbps, and 400 Gbps. Required transport to the ETS Basic Port is provided using an ETS CT as described above. Each ETS Basic Port must be associated with a minimum of one ETS EVC, one ETS E-EVC, one ETS I-EVC or one optional DSL Access Service Connection function. An ETS Basic Port may be associated with more than one ETS EVC, ETS E-EVC or ETS I-EVC. The bandwidth speed of an ETS Basic Port must be equal to or greater than the bandwidth speed of the associated ETS CT. The bandwidth speed of an optional DSL Access Service Connection function must be equal to the bandwidth speed of the associated ETS Basic Port.

 Transmittal No. 1676

Issued: October 17, 2022

Effective: November 1, 2022

Senior Director - Access Tariff Cost Development
60 Columbia Road, Bldg. A - 2nd Fl., Morristown, NJ 07960

ACCESS SERVICE

16. Public Packet Data Network (Cont'd)

16.3 Ethernet Transport Service (Cont'd)

16.3.4 Rate Regulations (Cont'd)

(A) Rate Categories (Cont'd)

(2) ETS Ports (Cont'd)

(b) ETS Interconnection Ports also provide the interface to the Telephone Company's ETS network and do not include the required transport facility between the CDP and the Telephone Company's ETS SWC. Used in conjunction with Special Access DS3, OC3 and/or OC12 Services, ETS Interconnection Ports permit the ETS customer to: 1) connect a CDP served by an ETS or non-ETS SWC to the Telephone Company's ETS network or 2) interconnect the Telephone Company's ETS network to an Ethernet network located in the serving territory of a non-adjacent telephone company.

(N)

(N)

(M)

(M)

Certain material currently found on this page previously appeared on Original Page 16-42.

Transmittal No. 1273

Issued: April 30, 2010

Effective:

August 18, 2010

Director - Access Tariffs
80 So. Jefferson Road, Whippany, NJ 07981

ACCESS SERVICE

16. Public Packet Data Network (Cont'd)

16.3 Ethernet Transport Service (Cont'd)

16.3.4 Rate Regulations (Cont'd)

(A) Rate Categories (Cont'd)

(2) ETS Ports (Cont'd)

ETS Interconnection Ports are available at bandwidth speeds of 44.736 Mbps (DS3), 155.52 Mbps (OC3) and 622.08 Mbps (OC12).

Required transport to the ETS Interconnection Port is provided using Special Access DS3, OC3 and/or OC12 Service facilities as described in Section 7, preceding. Each ETS Interconnection Port must be associated with a minimum of one ETS EVC, one ETS E-EVC, one ETS I-EVC or one optional DSL Access Service Connection function. An ETS Interconnection Port may be associated with more than one ETS EVC, ETS E-EVC or ETS I-EVC. The bandwidth speed of an ETS Interconnection Port must be equal to the bandwidth speed of the associated Special Access Service Channel Termination. The bandwidth speed of an optional DSL Access Service Connection function must be equal to the bandwidth speed of the associated ETS Interconnection Port.

Certain material previously found on this page now appears on Original Page 16-43.1.

Transmittal No. 1285

Issued: August 31, 2010

Effective:

APR 13 2011

Director - Access Tariffs
80 So. Jefferson Road, Whippany, NJ 07981

ACCESS SERVICE

16. Public Packet Data Network (Cont'd)

16.3 Ethernet Transport Service (Cont'd)

16.3.4 Rate Regulations (Cont'd)

(A) Rate Categories (Cont'd)

(2) ETS Ports (Cont'd)

Monthly and nonrecurring charges apply for each ETS Port ordered. The monthly recurring rate and nonrecurring charge are determined by the capacity and type of ETS Port ordered. Rates and charges are specified in Section 17.4.8(C)(2), following, or when applicable, as specified in Section 17.4.8(C)(9), following. The Telephone Company specific rate band assignment for the ETS Port rate element is specified in the Ethernet Transport Service (ETS) column in Section 17.5.1, following, or when applicable, as specified in Section 17.4.8(C)(9), following. (C)
(C)

Transmittal No. 1418

Issued: April 16, 2014

Effective: May 1, 2014

ACCESS SERVICE

16. Public Packet Data Network (Cont'd)16.3 Ethernet Transport Service (Cont'd)16.3.4 Rate Regulations (Cont'd)(A) Rate Categories (Cont'd)(3) ETS Ethernet Virtual Connections (ETS EVCs)

ETS EVCs are logical associations established by the Telephone Company across a shared transmission path that allow the ETS customer to transmit packets between any two ETS Ports located on the Telephone Company's ETS network. ETS EVCs are available in fixed bandwidth amounts of 2 Mbps, 5 Mbps, 10 Mbps, 20 Mbps, 50 Mbps, 100 Mbps, 200 Mbps, 250 Mbps, 300 Mbps, 400 Mbps, 500 Mbps, 600 Mbps, 700 Mbps, 750 Mbps, 800 Mbps, 900 Mbps, 1 Gbps, 2.5 Gbps, 5 Gbps, 10 Gbps, 50 Gbps, 100 Gbps, 200 Gbps, and 400 Gbps. The Telephone Company will establish ETS EVCs based upon the bandwidth capacity specified by the ETS customer on its Access Order. When ETS EVCs are ordered between two ETS Ports in the same SWC, the ETS customer will be charged the ETS Intraswitch EVC rate. When ETS EVCs are ordered between ETS Ports that are in different SWCs within the Telephone Company's serving territory, the ETS customer will be billed the ETS Interswitch EVC rate. (C)

An ETS customer may choose to order one or more Class of Service (CoS) levels on an existing ETS EVC or when ordering a new ETS EVC.

A CoS level provides priority routing of the ETS customer's traffic through the Telephone Company's network. When the customer orders a CoS level, the Telephone Company will configure its network equipment to recognize and transmit customer traffic according to the user priority value(s) populated by the ETS customer's CPE.

Transmittal No. 1676

Issued: October 17, 2022

Effective: November 1, 2022

ACCESS SERVICE

16. Public Packet Data Network (Cont'd)

16.3 Ethernet Transport Service (Cont'd)

16.3.4 Rate Regulations (Cont'd)

(A) Rate Categories (Cont'd)

(3) ETS Ethernet Virtual Connections (ETS EVCs)
(Cont'd)

A CoS level is available for use only on an ETS customer's ETS Intraswitch or Interswitch EVC when provided between two ETS Basic Ports located within the Telephone Company's serving territory. The CoS levels available for use with ETS are as described below:

(C)
(C)

- Real Time Class of Service/Quality of Service (RT CoS/QoS) supports applications that require minimal delay and low latency to facilitate steady data flow of user information through the ETS network. Examples of applications requiring a RT CoS/QoS level may include voice, high quality video, and circuit emulation for higher speed special access services. When ordered by the ETS customer, the Telephone Company's network will transport the customer's traffic across its network to meet the frame delay, inter frame delay variation and frame loss ratio parameters specified in the following Technical References:

(C)
(C)

(C)

(C)

- IEEE Standard 802.1D-2004, Sections 7, 9, 17 and Annex G provided the customer's CPE populates the user priority value field with a value of 6 and
- Implementation Agreement MEF 23.1, January 2012, Table 7, Label H, Regional Performance Tier.

(T)
(N)

(N)

Certain material previously found on this page now appears on Original Page 16-44.1.1.

Transmittal No. 1403

Issued: November 7, 2013

Effective: November 22, 2013

Director - Access Tariffs
80 So. Jefferson Road, Whippany, NJ 07981

ACCESS SERVICE

(N)

16. Public Packet Data Network (Cont'd)

16.3 Ethernet Transport Service (Cont'd)

16.3.4 Rate Regulations (Cont'd)

(A) Rate Categories (Cont'd)

(3) ETS Ethernet Virtual Connections (ETS EVCs)
(Cont'd)

(N)

When the ETS customer's CPE populates its packets with a user priority value of 6, the Telephone Company will provide the highest level of priority routing through its network of those packets up to the RT CoS/QoS level bandwidth capacity ordered before routing any of the ETS customer's other packets received with a user priority value of less than 6.

(M)

(C)

(M)

When one or more of the RT CoS/QoS performance criteria specified in the Technical References listed above is not met, the customer reports the performance failure to the Telephone Company and the performance failure does not result in a service interruption of the customer's ETS, the following provisions will apply in lieu of the credit allowance provisions for service interruptions specified in Section 2.4.4, preceding.

(N)

- No credit will be applied for the performance failure when the Telephone Company restores the customer's service to the required RT CoS/QoS performance criteria levels within four hours after receipt of the trouble report from the customer or when the Telephone Company determines during its trouble investigation that the customer's equipment caused the performance failure.

(N)

Certain material currently found on this page previously appeared on 1st Revised Page 16-44.1.

Transmittal No. 1403

Issued: November 7, 2013

Effective: November 22, 2013

Director - Access Tariffs
80 So. Jefferson Road, Whippany, NJ 07981

ACCESS SERVICE

(N)

16. Public Packet Data Network (Cont'd)

16.3 Ethernet Transport Service (Cont'd)

16.3.4 Rate Regulations (Cont'd)

(A) Rate Categories (Cont'd)

(3) ETS Ethernet Virtual Connections (ETS EVCs)
(Cont'd)

- When the Telephone Company fails to restore the customer's service to the required RT CoS/QoS performance criteria levels within four hours after receipt of the trouble report and the trouble is found to be in the Telephone Company's network, the Telephone Company will provide the customer with a service credit equal to 144/1440 of the undiscounted monthly charges for the impacted ETS EVC(s) and associated RT CoS/QoS level(s) for the initial four hour period and for each subsequent fractional four hour period until the performance failure is resolved. The total service credits due under this provision during a single billing month may not exceed the total undiscounted monthly charges for the impacted ETS EVC(s) and associated RT CoS/QoS level(s).

(N)

Transmittal No. 1403

Issued: November 7, 2013

Effective: November 22, 2013

Director - Access Tariffs
80 So. Jefferson Road, Whippany, NJ 07981

ACCESS SERVICE

16. Public Packet Data Network (Cont'd)

16.3 Ethernet Transport Service (Cont'd)

16.3.4 Rate Regulations (Cont'd)

(A) Rate Categories (Cont'd)

(3) ETS Ethernet Virtual Connections (ETS EVCs)
(Cont'd)

- Near Real Time CoS (NRT CoS) supports applications for which the data flow requires low delay variance and can tolerate some latency in ETS packet transmissions. Examples of applications requiring a NRT CoS level may include priority business applications, multimedia transmissions and streaming video services. When ordered by the ETS customer, the Telephone Company's network will transport traffic as described in IEEE 802.1D-2004, Sections 7, 9, 17 and Annex G provided the ETS customer's CPE populates the user priority value field with a value of 3, 4 or 5. When the ETS customer's CPE populates its packets with a user priority value of 5, 4, or 3, the Telephone Company will provide priority routing through its network of those packets up to the NRT CoS level bandwidth capacity ordered before routing any of the ETS customer's other packets received with a user priority value of less than 3. Unless otherwise requested by the customer and agreed upon by the Telephone Company, NRT CoS level priority routing provides that:
 - 1) packets received with a user priority value of 5 will receive higher priority routing through the Telephone Company's network than packets received with user priority values of 4 or 3 and
 - 2) packets received with a user priority value of 4 will receive higher priority routing through the Telephone Company's network than packets received with a user priority value of 3.

Transmittal No. 1403

Issued: November 7, 2013

Effective: November 22, 2013

Director - Access Tariffs

80 So. Jefferson Road, Whippany, NJ 07981

ACCESS SERVICE

16. Public Packet Data Network (Cont'd)

16.3 Ethernet Transport Service (Cont'd)

16.3.4 Rate Regulations (Cont'd)

(A) Rate Categories (Cont'd)

(3) ETS Ethernet Virtual Connections (ETS EVCs)
(Cont'd)

When an ETS customer orders a CoS, it must specify the CoS level(s) needed, the total bandwidth capacity for each CoS level and the associated ETS EVC(s). The ETS customer may order a CoS level to be established at the same time as the associated ETS Intraswitch or Interswitch EVC is established. The ETS customer may also order a CoS level to be added to an existing associated ETS Intraswitch or Interswitch EVC.

An ETS customer may order multiple CoS levels for use on the same ETS EVC. The total bandwidth capacity ordered for all CoS levels associated with a single ETS EVC cannot exceed the bandwidth capacity of the ETS EVC. For example, an ETS customer with a 500 Mbps ETS Interswitch EVC between two 500 Mbps ETS Basic Ports could order 300 Mbps of NRT CoS and 200 Mbps of RT CoS/QoS.

(T)
(T)

The ETS customer's traffic will receive priority routing treatment up to the available bandwidth capacity of the CoS level ordered. Any ETS customer traffic received by the Telephone Company's network beyond the available bandwidth capacity of the CoS level(s) ordered will be transported by the Telephone Company's network at best effort.

Transmittal No. 1403

Issued: November 7, 2013

Effective: November 22, 2013

Director - Access Tariffs
80 So. Jefferson Road, Whippany, NJ 07981

ACCESS SERVICE

16. Public Packet Data Network (Cont'd)

16.3 Ethernet Transport Service (Cont'd)

16.3.4 Rate Regulations (Cont'd)

(A) Rate Categories (Cont'd)

(3) ETS Ethernet Virtual Connections (ETS EVCs)
(Cont'd)

If an ETS customer orders a CoS level with a bandwidth capacity that is less than the total bandwidth capacity of the associated ETS EVC, the remaining non-assigned capacity will be transported by the Telephone Company's network at best effort. For example, an ETS customer with a 100 Mbps ETS Interswitch EVC between two 100 Mbps ETS Basic Ports orders 70 Mbps of NRT CoS. If the ETS customer's CPE populates the user priority value field with a value of 3 and transmits at the full capacity of the ETS EVC, the Telephone Company's network would transport 70 Mbps of the ETS customer's traffic using NRT CoS routing treatment and the remaining non-assigned 30 Mbps at best effort.

(T)

(T)

The total bandwidth capacity of all CoS levels associated with one or more ETS EVCs connected to the same ETS Basic Port may not exceed the total bandwidth capacity available on that ETS Basic Port.

Transmittal No. 1403

Issued: November 7, 2013

Effective: November 22, 2013

Director - Access Tariffs
80 So. Jefferson Road, Whippany, NJ 07981

ACCESS SERVICE

16. Public Packet Data Network (Cont'd)

16.3 Ethernet Transport Service (Cont'd)

16.3.4 Rate Regulations (Cont'd)

(A) Rate Categories (Cont'd)

(3) ETS Ethernet Virtual Connections (ETS EVCs)
(Cont'd)

When a CoS level has been established on an associated ETS EVC and the user priority value field is populated with a value that is equal to or less than the CoS level ordered, the Telephone Company's network will transport the ETS customer's traffic using the user priority value populated. For example, if an ETS customer has a 250 Mbps ETS Intraswitch EVC, orders 100 Mbps of RT CoS/QoS (i.e., associated with user priority value of 6) and transmits 250 Mbps of traffic with a user priority value of 3 populated (i.e., NRT CoS), the Telephone Company's network would transport 100 Mbps of the ETS customer's traffic using NRT CoS routing treatment and the remaining non-assigned 150 Mbps at best effort. (T)

When a CoS level has been established on an associated ETS EVC and the user priority value field is populated with a value greater than the CoS level ordered, the Telephone Company's network will transport the ETS customer's traffic using the user priority value of the CoS level ordered. For example, if an ETS customer has a 250 Mbps ETS Intraswitch EVC, orders 100 Mbps of NRT CoS (i.e., associated with user priority value 3, 4 or 5) and transmits 250 Mbps of traffic with a user priority value of 6 populated (i.e., RT CoS/QoS), the Telephone Company's network would transport 100 Mbps of the ETS customer's traffic using NRT CoS routing treatment and the remaining non-assigned 150 Mbps at best effort. (T)

Transmittal No. 1403

Issued: November 7, 2013

Effective: November 22, 2013

Director - Access Tariffs
80 So. Jefferson Road, Whippany, NJ 07981

ACCESS SERVICE

16. Public Packet Data Network (Cont'd)

16.3 Ethernet Transport Service (Cont'd)

16.3.4 Rate Regulations (Cont'd)

(A) Rate Categories (Cont'd)

(3) ETS Ethernet Virtual Connections (ETS EVCs)
(Cont'd)

When a CoS level has been established on an associated ETS EVC and the user priority value field is not populated, the Telephone Company's network will transport the ETS customer's traffic at best effort.

When a CoS level has not been ordered for use on an associated ETS EVC, the Telephone Company's network will transport the ETS customer's traffic that transits the ETS EVC at best effort.

Monthly and nonrecurring charges apply for each ETS EVC ordered. The monthly recurring rate and nonrecurring charge are based upon the bandwidth capacity ordered and whether the associated ETS Ports are located within one SWC (Intraswitch) or between different SWCs (Interswitch). Rates and charges are specified in Section 17.4.8(C)(3), following, or when applicable, as specified in Section 17.4.8(C)(9), following. The Telephone Company specific rate band assignment for the ETS Ethernet Virtual Connection rate element is specified in the Ethernet Transport Service (ETS) column in Section 17.5.1, following, or when applicable, as specified in Section 17.4.8(C)(9), following.

(C)

Transmittal No. 1418

Issued: April 16, 2014

Effective: May 1, 2014

Director - Access Tariffs

80 So. Jefferson Road, Whippany, NJ 07981

ACCESS SERVICE

16. Public Packet Data Network (Cont'd)

16.3 Ethernet Transport Service (Cont'd)

16.3.4 Rate Regulations (Cont'd)

(A) Rate Categories (Cont'd)

(3) ETS Ethernet Virtual Connections (ETS EVCs)
(Cont'd)

A monthly recurring charge applies based on the total bandwidth capacity of each CoS level ordered and the type (i.e., Intraswitch or Interswitch) of the associated ETS EVC. The monthly recurring charge is calculated by multiplying the number of megabits ordered by the applicable per megabit rate for the specified CoS level, which is based upon the associated ETS EVC type (i.e., Intraswitch or Interswitch). Rates are specified in Sections 17.4.8(C) (3) (a) (ii) and (b) (ii), following, or when applicable, as specified in Section 17.4.8(C) (9), following. The Telephone Company specific rate band assignment for the ETS Class of Service rate element is specified in the Ethernet Transport Service (ETS) column in Section 17.5.1, following, or when applicable, in Section 17.4.8(C) (9), following.

(C)
(C)
|
(C)

As an example, an ETS customer with a single 100 Mbps ETS Interswitch EVC between two 100 Mbps ETS Basic Ports orders a total of 30 Mbps of NRT CoS. The monthly charge would be calculated by multiplying the per megabit rate for the NRT CoS level for the associated 100 Mbps ETS Interswitch EVC by 30. The monthly recurring charge for the CoS level in this example would apply in addition to the monthly recurring charges for the 100 Mbps ETS Interswitch EVC and two 100 Mbps ETS Basic Ports.

Transmittal No. 1561

Issued: November 16, 2018

Effective: December 1, 2018

Director - Access Tariffs
80 So. Jefferson Road, Whippany, NJ 07981

ACCESS SERVICE

(N)

16. Public Packet Data Network (Cont'd)

16.3 Ethernet Transport Service (Cont'd)

16.3.4 Rate Regulations (Cont'd)

(A) Rate Categories (Cont'd)

(3) ETS Ethernet Virtual Connections (ETS EVCs)
(Cont'd)

An Access Order Charge applies to establish the initial CoS level on an existing ETS EVC. Only one Access Order Charge would apply to establish multiple CoS levels on an existing ETS EVC with no existing CoS level on the same access order. An Access Order Charge does not apply to make CoS level changes on an existing ETS EVC that has at least one CoS level already established.

The ETS Design Change Charge will apply per ETS EVC, as described in Section 16.3.4(B)(2)(d), below, when an ETS customer elects to make one or more of the following changes on an existing ETS EVC that has at least one CoS level already established: (1) changing the bandwidth capacity of an existing CoS level; (2) adding an additional CoS level; (3) replacing one type of CoS level with another type of CoS level; or (4) removing an existing CoS level from the associated ETS EVC.

(N)

Transmittal No. 1302

Issued: March 8, 2011

Effective:

JUN 06 2011

Director - Access Tariffs
80 So. Jefferson Road, Whippany, NJ 07981

ACCESS SERVICE

16. Public Packet Data Network (Cont'd)16.3 Ethernet Transport Service (Cont'd)16.3.4 Rate Regulations (Cont'd)(A) Rate Categories (Cont'd)(4) ETS Extended Ethernet Virtual Connections
(ETS E-EVCS)

ETS E-EVCs are logical associations established by the Telephone Company across a shared transmission path that allow the ETS customer to transmit packets to and receive packets from an ETS Port located in the Telephone Company's ETS network to another telephone company's Ethernet network located in an adjacent serving territory. ETS E-EVCs can be established between two ETS Basic Ports, between two ETS Interconnection Ports or between an ETS Basic Port and an ETS Interconnection Port. ETS E-EVCs are available in fixed bandwidth amounts of 2 Mbps, 5 Mbps, 10 Mbps, 20 Mbps, 50 Mbps, 100 Mbps, 200 Mbps, 250 Mbps, 300 Mbps, 400 Mbps, 500 Mbps, 600 Mbps, 700 Mbps, 750 Mbps, 800 Mbps, 900 Mbps, 1 Gbps, 2.5 Gbps, 5 Gbps, 10 Gbps, 50 Gbps, 100 Gbps, 200 Gbps, and 400 Gbps. The Telephone Company will establish ETS E-EVCs based upon the bandwidth capacity specified by the ETS customer on its Access Order.

(C)

(C)

Transmittal No. 1676

Issued: October 17, 2022

Effective: November 1, 2022

Senior Director - Access Tariff Cost Development
60 Columbia Road, Bldg. A - 2nd Fl., Morristown, NJ 07960

ACCESS SERVICE

16. Public Packet Data Network (Cont'd)16.3 Ethernet Transport Service (Cont'd)16.3.4 Rate Regulations (Cont'd)(A) Rate Categories (Cont'd)(4) ETS Extended Ethernet Virtual Connections
(ETS E-EVCS) (Cont'd)

Monthly and nonrecurring charges apply for each ETS E-EVC ordered. The monthly recurring rate and nonrecurring charge are based upon the bandwidth capacity of the ETS E-EVC ordered. Rates and charges are specified in Section 17.4.8(C)(4), following, or when applicable, as specified in Section 17.4.8(C)(9), following. The Telephone Company specific rate band assignment for the ETS Extended Ethernet Virtual Connection rate element is specified in the Ethernet Transport Service (ETS) column (C) in Section 17.5.1, following, or when applicable, as specified in in Section 17.4.8(C)(9), following.

(5) ETS Interconnected Ethernet Virtual
Connections (ETS I-EVCS)

ETS I-EVCs are logical associations established by the Telephone Company across a shared transmission path that allow the ETS customer to transmit packets to and receive packets from an ETS Port located in the Telephone Company's ETS network to another telephone company's Ethernet network located in a non-adjacent

Transmittal No. 1418

Issued: April 16, 2014

Effective: May 1, 2014

Director - Access Tariffs
80 So. Jefferson Road, Whippany, NJ 07981

ACCESS SERVICE

16. Public Packet Data Network (Cont'd)16.3 Ethernet Transport Service (Cont'd)16.3.4 Rate Regulations (Cont'd)(A) Rate Categories (Cont'd)(5) ETS Interconnected Ethernet Virtual Connections (ETS I-EVCS) (Cont'd)

serving territory. ETS I-EVCs can only be used when the airline distance between the ETS SWCs serving the ETS customer's CDPs is seventy-five miles or less. When the airline distance is greater than seventy-five miles, the ETS customer will use a combination of ETS elements and Special Access Service elements as depicted in Figure 6, above, to connect to its CDP in the non-adjacent serving territory. The Telephone Company will determine the airline distance between the ETS SWCs using the V&H Coordinates method, as described in the NATIONAL EXCHANGE CARRIER ASSOCIATION, INC. TARIFF F.C.C. NO. 4.

ETS I-EVCs can be established between two ETS Basic Ports, between two ETS Interconnection Ports or between an ETS Basic Port and an ETS Interconnection Port. ETS I-EVCs are available in fixed bandwidth amounts of 2 Mbps, 5 Mbps, 10 Mbps, 20 Mbps, 50 Mbps, 100 Mbps, 200 Mbps, 250 Mbps, 300 Mbps, 400 Mbps, 500 Mbps, 600 Mbps, 700 Mbps, 750 Mbps, 800 Mbps, 900 Mbps, 1 Gbps, 2.5 Gbps, 5 Gbps, 10 Gbps, 50 Gbps, 100 Gbps, 200 Gbps, and 400 Gbps. The Telephone Company will establish ETS I-EVCs based upon the bandwidth capacity specified by the ETS customer on its Access Order.

(C)
(C)

Transmittal No. 1676

Issued: October 17, 2022

Effective: November 1, 2022

ACCESS SERVICE

16. Public Packet Data Network (Cont'd)

16.3 Ethernet Transport Service (Cont'd)

16.3.4 Rate Regulations (Cont'd)

(A) Rate Categories (Cont'd)

(5) ETS Interconnected Ethernet Virtual Connections (ETS I-EVCS) (Cont'd)

Monthly and nonrecurring charges apply for each ETS I-EVC based upon the bandwidth capacity ordered by the ETS customer and whether the airline distance between the ETS SWCs serving the ETS customer's CDPs is: 1) less than or equal to fifty miles or 2) between fifty-one and seventy-five miles. Rates and charges are specified in Section 17.4.8(C)(5), following, or when applicable, as specified in Section 17.4.8(C)(9), following.

(C)
|
(C)

Transmittal No. 1327

Issued: December 5, 2011

Effective: December 20, 2011

Director - Access Tariffs
80 So. Jefferson Road, Whippany, NJ 07981

ACCESS SERVICE

16. Public Packet Data Network (Cont'd)

16.3 Ethernet Transport Service (Cont'd)

16.3.4 Rate Regulations (Cont'd)

(A) Rate Categories (Cont'd)

(6) Optional Features and Functions

(T)

(a) DSL Access Service Connection

Where available, ETS Basic or Interconnection Ports may be equipped with the DSL Access Service Connection function. The function provides for the interconnection of ETS with ADSL Access Service as described in Section 8.1, preceding, and with SDSL Access Service as described in Section 8.2, preceding, provided by the Telephone Company under this tariff. The function also provides for the interconnection of ETS with a wireline broadband Internet transmission service provided on a non-tariffed, common carrier basis. This optional function allows the ETS customer to receive ADSL, SDSL, and/or wireline broadband Internet transmission service data traffic from and transmit ADSL, SDSL, and/or wireline broadband Internet transmission service data traffic to its end user customers.

The speed of the DSL Access Service Connection function ordered by the ETS customer must equal the speed of the associated ETS Port.

Certain material previously found on this page now appears on 1st Revised Page 16-47.

Transmittal No. 1273

Issued: April 30, 2010

Effective:

August 18, 2010

Director - Access Tariffs
80 So. Jefferson Road, Whippany, NJ 07981

ACCESS SERVICE

16. Public Packet Data Network (Cont'd)

16.3 Ethernet Transport Service (Cont'd)

16.3.4 Rate Regulations (Cont'd)

(A) Rate Categories (Cont'd)

(6) Optional Features and Functions (Cont'd)

(a) DSL Access Service Connection
(Cont'd)

As described in Sections 8.1 and 8.2, preceding, the DSL Access Service Connection Point may be located within the serving territory of the Telephone Company, or in the serving territory of another telephone company when used in conjunction with ETS. (C)

The availability of the DSL Access Service Connection function is designated by the Telephone Company in the NATIONAL EXCHANGE CARRIER ASSOCIATION, INC. Tariff F.C.C. No. 4.

A nonrecurring charge applies per port to equip the ETS Port with the DSL Access Service Connection function. Rates and charges are specified in Section 17.4.8(C)(6)(a)(i) and (ii), following, or when applicable, as specified in Section 17.4.8(C)(9), following.

Transmittal No. 1434

Issued: October 23, 2014

Effective: November 7, 2014

Director - Access Tariffs
80 So. Jefferson Road, Whippany, NJ 07981

ACCESS SERVICE

16. Public Packet Data Network (Cont'd)16.3 Ethernet Transport Service (Cont'd)16.3.4 Rate Regulations (Cont'd)(A) Rate Categories (Cont'd)(6) Optional Features and Functions (Cont'd)(a) DSL Access Service Connection
(Cont'd)

- (i) Where suitable facilities exist, an ETS customer may also order an ETS MultiMedia Virtual Circuit Channel (ETS MM-VCC), available in 10 Mbps increments of bandwidth capacity, between its CDP and the premises of its end user customer. There are two types of ETS MM-VCCs available: (1) One-Way ETS MM-VCC and (2) Two-Way ETS MM-VCC.

The One-Way ETS MM-VCC enables the ETS customer to send high speed multimedia transmissions to its end user customer's premises, provided such end user customer's premises is equipped with ADSL Access Service provided by the Telephone Company under this tariff as described in Section 8.1, preceding. One-Way ETS MM-VCCs are only available when the ETS customer's CDP, the ETS customer's end user customer's premises and the Telephone Company's DSL Access Service Connection Point SWC are all located within the serving territory of the Telephone Company. The total transmission capacity for any ADSL Access Service using the One-Way ETS MM-VCC option may not exceed 1

(T)

Transmittal No. 1690

Issued: April 14, 2023

Effective: April 29, 2023

Senior Director - Access Tariff Cost Development
60 Columbia Road, Bldg. A - 2nd Fl., Morristown, NJ 07960

ACCESS SERVICE

16. Public Packet Data Network (Cont'd)16.3 Ethernet Transport Service (Cont'd)16.3.4 Rate Regulations (Cont'd)(A) Rate Categories (Cont'd)(6) Optional Features and Functions (Cont'd)(a) (i) DSL Access Service Connection
(Cont'd)

The Two-Way ETS MM-VCC enables the ETS customer to receive from and send to its end user customer's premises high speed multimedia transmissions, provided such end user customer's premises is equipped with ADSL or SDSL Access Service provided by the Telephone Company under this tariff as described in Sections 8.1 and 8.2, preceding. As of March 1, 2019, new orders for Two-Way ETS MM-VCCs are only available for use: (1) with an ADSL or SDSL Access Service having both downstream and upstream transmission capabilities of 1 Mbps or greater, and (2) when the ETS customer's CDP, the ETS customer's end user customer's premises and the Telephone Company's DSL Access Service Connection Point SWC are all located within the serving territory of the Telephone Company. The total transmission capacity for any ADSL or SDSL Access Service using the Two-Way ETS MM-VCC option may not exceed 1 Gbps.

(T)

Transmittal No. 1690

Issued: April 14, 2023

Effective: April 29, 2023

Senior Director - Access Tariff Cost Development
60 Columbia Road, Bldg. A - 2nd Fl., Morristown, NJ 07960

ACCESS SERVICE

(N)

16. Public Packet Data Network (Cont'd)

16.3 Ethernet Transport Service (Cont'd)

16.3.4 Rate Regulations (Cont'd)

(A) Rate Categories (Cont'd)

(6) Optional Features and Functions (Cont'd)

(a) (i) DSL Access Service Connection
(Cont'd)

(N)

ETS MM-VCCs do not increase the bandwidth capacity of ETS CTs, ETS Ports, ETS EVCs and/or Special Access Service Channel Terminations, Channel Mileage Facility and Channel Mileage Terminations used by the ETS customer to connect its CDP to the DSL Access Service Connection Point SWC.

(M)

(M)

Certain material currently found on this page previously appeared on 1st Revised Page 16-48.

Transmittal No. 1428

Issued: August 15, 2014

Effective: August 30, 2014

Director - Access Tariffs
80 So. Jefferson Road, Whippany, NJ 07981

ACCESS SERVICE

16. Public Packet Data Network (Cont'd)

16.3 Ethernet Transport Service (Cont'd)

16.3.4 Rate Regulations (Cont'd)

(A) Rate Categories (Cont'd)

(6) Optional Features and Functions (Cont'd)

(a) (i) DSL Access Service Connection (T)
 (Cont'd)

Transmission speed across the ETS MM-VCC is not guaranteed and may be affected by factors that affect the actual speeds delivered, including the ADSL or SDSL Access Service customer's distance from the Telephone Company SWC, condition of the facilities, and any capacity limitations in the ETS customer's network design. (C)

At each premises at which the ETS customer wants to order an ETS MM-VCC, the ETS customer must specify on its Access Order: (1) its end user customer's premises location; (2) the type of ETS MM-VCC (i.e., one-way or two-way); and (3) the total number of 10 Mbps bandwidth capacity increments required to that location. For example, an ETS customer requires an additional 40 Mbps of bandwidth capacity to one of its SDSL end user customers to send and receive high speed multimedia transmissions. On its Access Order to the Telephone Company, the ETS customer would specify the end user customer's premises address and order one Two-Way ETS MM-VCC made up of four 10 Mbps increments. (C)

Transmittal No. 1428

Issued: August 15, 2014

Effective: August 30, 2014

Director - Access Tariffs
 80 So. Jefferson Road, Whippany, NJ 07981

ACCESS SERVICE

16. Public Packet Data Network (Cont'd)

16.3 Ethernet Transport Service (Cont'd)

16.3.4 Rate Regulations (Cont'd)

(A) Rate Categories (Cont'd)

(6) Optional Features and Functions (Cont'd)

(a) (i) DSL Access Service Connection
(Cont'd)

In the above example, the Telephone Company would bill the ETS customer for one ETS MM-VCC nonrecurring charge. The monthly recurring rate for this Two-Way ETS MM-VCC would be calculated at four times the two-way 10 Mbps increment rate.

(C)

Monthly and nonrecurring charges apply to each ETS MM-VCC established by the Telephone Company. As specified in Section 5.4.1, preceding, an Access Order Charge does not apply to establish an ETS MM-VCC. The ETS customer may order multiple ETS MM-VCCs to multiple end users' locations on a single Access Order. The applicable nonrecurring charge for each ETS MM-VCC established would apply. The ETS MM-VCC charges apply in addition to the nonrecurring charge for equipping the ETS Port with the DSL Access Service Connection function. Rates and charges are specified in Section 17.4.8(C)(6)(a)(iii), following, or when applicable, as specified in Section 17.4.8(C)(9), following. The Telephone Company specific rate band assignment for the ETS Multimedia Virtual Circuit Channel rate element is specified in the Ethernet Transport Service (ETS) column in Section 17.5.1, following, or when applicable, as specified in Section 17.4.8(C)(9), following.

(C)

(C)

(C)

(C)

Transmittal No. 1468

Issued: October 28, 2015

Effective: November 12, 2015

Director - Access Tariffs
80 So. Jefferson Road, Whippany, NJ 07981

ACCESS SERVICE

16. Public Packet Data Network (Cont'd)16.3 Ethernet Transport Service (Cont'd)16.3.4 Rate Regulations (Cont'd)(A) Rate Categories (Cont'd)(6) Optional Features and Functions (Cont'd)(a) (i) DSL Access Service Connection
(Cont'd)

The Telephone Company will waive the ETS MM-VCC monthly rate when the local exchange telephone service, ADSL or SDSL Access Service and ETS MM-VCC are provided from the same serving wire center where the Telephone Company has located its DSL Access Service Connection Point. The ETS MM-VCC nonrecurring charge will apply.

When an ETS customer elects to change the bandwidth capacity of an existing ETS MM-VCC, remove an existing ETS MM-VCC from its associated ADSL or SDSL Access Service, or convert from a One-Way ETS MM-VCC to a Two-Way ETS MM-VCC or vice versa, the ETS MM-VCC nonrecurring charge will not apply. In lieu of such charge, the ETS Design Change Charge will apply, as described in Section 16.3.4(B)(2)(d), following.

(T)

When an ETS customer disconnects an ETS MM-VCC and the associated ADSL or SDSL Access Service at the same time, neither the ETS MM-VCC nonrecurring charge nor the ETS Design Change Charge will apply.

(T)

Transmittal No. 1690

Issued: April 14, 2023

Effective: April 29, 2023

Senior Director - Access Tariff Cost Development
60 Columbia Road, Bldg. A - 2nd Fl., Morristown, NJ 07960

ACCESS SERVICE

16. Public Packet Data Network (Cont'd)16.3 Ethernet Transport Service (Cont'd)16.3.4 Rate Regulations (Cont'd)(A) Rate Categories (Cont'd)(6) Optional Features and Functions (Cont'd)(a) DSL Access Service Connection
(Cont'd)

- (ii) Where suitable facilities exist, an ETS customer that requires the ability to transmit and receive low speed data using virtual local area network tagged frames may also order an ETS Low Bit Rate Virtual Circuit Channel (ETS LBR-VCC) between its CDP and the premises of its end user customer, provided such end user customer's premises is equipped with ADSL or SDSL Access Service provided by the Telephone Company under this tariff as described in Sections 8.1 and 8.2, preceding. This optional function allows the customer to transmit and receive tagged frames which were formatted by the customer's CPE in conformance with the standards specified in Technical Reference, IEEE Std 802.1Q - 2018, Sections 5 through 12 and Annexes E and G. ETS LBR-VCCs are only available when the ETS customer's CDP, the ETS customer's end user premises and the Telephone Company's DSL Access Service Connection Point SWC are all located within the serving territory of the Telephone Company. ETS LBR-VCCs do not increase the bandwidth capacity of ETS CTs, ETS Ports, ETS EVCs and/or Special Access Service Channel Terminations, Channel Mileage Facility and Channel Mileage Terminations used by the ETS customer to connect its CDP to the DSL Access Service Connection Point SWC.

(T)

Transmittal No. 1554

Issued: August 17, 2018

Effective: September 1, 2018

Director - Access Tariffs
80 So. Jefferson Road, Whippany, NJ 07981

ACCESS SERVICE

(N)

16. Public Packet Data Network (Cont'd)

16.3 Ethernet Transport Service (Cont'd)

16.3.4 Rate Regulations (Cont'd)

(A) Rate Categories (Cont'd)

(6) Optional Features and Functions (Cont'd)

(a) DSL Access Service Connection
(Cont'd)

Transmission speed across the ETS LBR-VCC is not guaranteed and may be affected by factors that affect the actual speeds delivered, including the ADSL or SDSL Access Service customer's distance from the Telephone Company SWC, condition of the facilities, and any capacity limitations in the ETS customer's network design.

At each premises to which the ETS customer wants to transmit and receive low speed data using an ETS LBR-VCC, the ETS customer must specify on its Access Order its end user customer's premises location and the total number of 64 kbps bandwidth capacity increments required to that location. For example, an ETS customer requires an additional 128 kbps of bandwidth capacity to one of its end user customers. On its Access Order to the Telephone Company, the ETS customer would specify the end user customer premises address and order one ETS LBR-VCC made up of two 64 kbps increments.

(N)

Transmittal No. 1291

Issued: October 28, 2010

Effective: -----

MAY 31 2011

Director - Access Tariffs
80 So. Jefferson Road, Whippany, NJ 07981

ACCESS SERVICE

(N)

16. Public Packet Data Network (Cont'd)

16.3 Ethernet Transport Service (Cont'd)

16.3.4 Rate Regulations (Cont'd)

(A) Rate Categories (Cont'd)

(6) Optional Features and Functions (Cont'd)

(a) DSL Access Service Connection
(Cont'd)

In the above example, the Telephone Company would bill the ETS customer for one ETS LBR-VCC nonrecurring charge and one Access Order Charge. The monthly recurring rate for this ETS LBR-VCC would be calculated at two times the 64 kbps increment rate.

Monthly and nonrecurring charges apply to each ETS LBR-VCC established by the Telephone Company in addition to any applicable Access Order Charges specified in Section 5.4.1, preceding. The ETS customer may order multiple ETS LBR-VCCs to multiple end users' locations on a single Access Order, in which case only one Access Order Charge would apply for that order in addition to the applicable nonrecurring charge for each ETS LBR-VCC established. The ETS LBR-VCC charges apply in addition to the nonrecurring charge for equipping the ETS Port with the DSL Access Service Connection function. Rates and charges are specified in Section 17.4.8(C) (6) (a) (iv), following, or when applicable, as specified in Section 17.4.8(C) (9), following.

(N)

Transmittal No. 1291

Issued: October 28, 2010

Effective:

MAY 31 2011

Director - Access Tariffs
80 So. Jefferson Road, Whippany, NJ 07981

ACCESS SERVICE

16. Public Packet Data Network (Cont'd)16.3 Ethernet Transport Service (Cont'd)16.3.4 Rate Regulations (Cont'd)(A) Rate Categories (Cont'd)(6) Optional Features and Functions (Cont'd)(a) DSL Access Service Connection
(Cont'd)

When an ETS customer elects to change the bandwidth capacity of an existing ETS LBR-VCC or to remove an existing ETS LBR-VCC from its associated ADSL or SDSL Access Service, the ETS LBR-VCC nonrecurring charge will not apply. In lieu of such charge, the ETS Design Change Charge will apply, as described in (d), below.

(T)

When an ETS customer disconnects an ETS LBR-VCC and the associated ADSL or SDSL Access Service at the same time, neither the ETS LBR-VCC nonrecurring charge nor the ETS Design Change Charge will apply.

(T)

Transmittal No. 1690

Issued: April 14, 2023

Effective: April 29, 2023

Senior Director - Access Tariff Cost Development
60 Columbia Road, Bldg. A - 2nd Fl., Morristown, NJ 07960

ACCESS SERVICE

16. Public Packet Data Network (Cont'd)

16.3 Ethernet Transport Service (Cont'd)

16.3.4 Rate Regulations (Cont'd)

(A) Rate Categories (Cont'd)

(6) Optional Features and Functions (Cont'd)

(b) ETS Port Protection

Where suitable facilities exist, an ETS customer that requires stand-by capability between an ETS Basic Port at the Telephone Company's ETS SWC and its CDP may order the ETS Port Protection feature. (C)

This feature establishes a stand-by ETS Basic Port, associated stand-by ETS CT and dedicated capacity to be activated should a failure occur in the Primary ETS Basic Port at the Telephone Company's ETS SWC or associated ETS CT between the CDP and the ETS SWC. The ETS switch will automatically redirect the ETS customer's traffic to the stand-by ETS Basic Port and associated stand-by ETS CT as well as to any EVC(s) (i.e., Intraswitch, Interswitch, Extended and/or Interconnected), assigned CoS levels, and, if applicable, the DSL Access Service Connection function, ETS MM-VCCs and ETS LBR-VCCs associated with the Primary ETS Basic Port. When ordered by the ETS customer, the Telephone Company's network will redirect traffic as described in IEEE 802.1D-2004, Section 17. (C)

Transmittal No. 1380

Issued: April 8, 2013

Effective: April 23, 2013

Director - Access Tariffs
80 So. Jefferson Road, Whippany, NJ 07981

ACCESS SERVICE

16. Public Packet Data Network (Cont'd)

16.3 Ethernet Transport Service (Cont'd)

16.3.4 Rate Regulations (Cont'd)

(A) Rate Categories (Cont'd)

(6) Optional Features and Functions (Cont'd)

(b) ETS Port Protection (Cont'd)

For purposes of this section, the Primary ETS Basic Port is the ETS Basic Port on which the customer orders the establishment of the ETS Port Protection feature. The stand-by ETS Basic Port provides the same functionality and bandwidth capacity as the Primary ETS Basic Port. The stand-by ETS CT provides the same functionality and bandwidth capacity as the associated ETS CT for the Primary ETS Basic Port.

In addition to any applicable Access Order Charges specified in Section 5.4.1, preceding, monthly and nonrecurring charges apply for each ETS Port Protection feature established on an existing or new Primary ETS Basic Port. The monthly and nonrecurring charges are based upon the bandwidth capacity of the Primary ETS Basic Port and whether the CDP is located within 300 feet of the ETS SWC or more than 300 feet from the ETS SWC.

(C)
|
(C)

Transmittal No. 1415

Issued: March 17, 2014

Effective: April 1, 2014

Director - Access Tariffs
80 So. Jefferson Road, Whippany, NJ 07981

ACCESS SERVICE

16. Public Packet Data Network (Cont'd)

16.3 Ethernet Transport Service (Cont'd)

16.3.4 Rate Regulations (Cont'd)

(A) Rate Categories (Cont'd)

(6) Optional Features and Functions (Cont'd)

(b) ETS Port Protection (Cont'd)

Rates and charges are specified in Section 17.4.8(C)(6)(b), following, or when applicable, as specified in Section 17.4.8(C)(9), following.

(M)

The ETS customer specifies on the order the Primary ETS Basic Port on which the ETS Port Protection feature is to be established. An Access Order Charge, per order, applies to establish the ETS Port Protection feature. When the ETS customer orders the ETS Port Protection feature at the same time as it orders the associated Primary ETS Basic Port, the Access Order Charge will not apply. The ETS customer may order the ETS Port Protection feature for multiple Primary ETS Basic Ports on a single Access Order, in which case only one Access Order Charge would apply for that order in addition to the applicable ETS Port Protection nonrecurring charge for each feature established on each Primary ETS Basic Port.

(M)

Certain material currently found on this page previously appeared on Original Page 16-51.6.

Certain material previously found on this page can now be found on Original Page 16-51.8.

Transmittal No. 1380

Issued: April 8, 2013

Effective: April 23, 2013

Director - Access Tariffs
80 So. Jefferson Road, Whippany, NJ 07981

ACCESS SERVICE

(N)

16. Public Packet Data Network (Cont'd)

16.3 Ethernet Transport Service (Cont'd)

16.3.4 Rate Regulations (Cont'd)

(A) Rate Categories (Cont'd)

(6) Optional Features and Functions (Cont'd)

(b) ETS Port Protection (Cont'd)

(N)

The ETS Port Protection feature will automatically be discontinued when the associated Primary ETS Basic Port is disconnected. Neither the ETS Port Protection nonrecurring charge nor the Access Order Charge applies for the discontinuance of the ETS Port Protection feature.

(M)

(M)

When the ETS customer elects to increase the bandwidth capacity on an existing ETS Basic Port equipped with the ETS Port Protection feature, the ETS Design Change Charge, as described in Section 16.3.4(B)(2)(d), following, will apply per ETS Port Protection feature in lieu of the ETS Port Protection nonrecurring charge.

(N)

(N)

Certain material currently on this page previously appeared on Original Page 16-51.7

Transmittal No. 1380

Issued: April 8, 2013

Effective: April 23, 2013

Director - Access Tariffs
80 So. Jefferson Road, Whippany, NJ 07981

ACCESS SERVICE

16. Public Packet Data Network (Cont'd)16.3 Ethernet Transport Service (Cont'd)16.3.4 Rate Regulations (Cont'd)(A) Rate Categories (Cont'd)(6) Optional Features and Functions (Cont'd)(c) ETS Bandwidth Add-On (ETS BAO)

Where suitable facilities exist, an ETS customer that requires additional bandwidth capacity may order the ETS Bandwidth Add-On (ETS BAO) feature. This optional feature enables the ETS customer to order additional bandwidth capacity in 10 Mbps or 500 Mbps increments to be added to ETS Basic Ports, ETS CTs, ETS EVCs, ETS E-EVCs and ETS I-EVCs.

The ETS BAO 10 Mbps increment is available for speed options of 20 Mbps, 50 Mbps, 100 Mbps, 200 Mbps, 250 Mbps, 300 Mbps, 400 Mbps, 500 Mbps, 600 Mbps, 700 Mbps, 750 Mbps, 800 Mbps, and 900 Mbps. The maximum speed possible using 10 Mbps increments is 1 Gbps.

(C)

The ETS BAO 500 Mbps increment is available for speed options of 1 Gbps, 2.5 Gbps, and 5 Gbps. The maximum speed possible using 500 Mbps increments is 10 Gbps.

The ETS BAO feature is only available on the above listed ETS rate elements and speed options when provided within the serving territory of the Telephone Company.

 Transmittal No. 1680

Issued: December 16, 2022

Effective: December 31, 2022

ACCESS SERVICE

16. Public Packet Data Network (Cont'd)16.3 Ethernet Transport Service (Cont'd)16.3.4 Rate Regulations (Cont'd)(A) Rate Categories (Cont'd)(6) Optional Features and Functions (Cont'd)(c) ETS Bandwidth Add-On (ETS BAO) (Cont'd)

For each ETS BAO feature, the ETS customer may order one 10 Mbps increment, one 500 Mbps Increment, multiple 10 Mbps increments or multiple 500 Mbps increments. The ETS BAO feature may be added to an eligible ETS rate element at the same time the underlying ETS rate element is initially installed or subsequently added to an existing ETS rate element. An ETS BAO feature would be ordered for each eligible ETS rate element and speed option combination based upon the ETS customer's bandwidth needs.

Certain material formerly found on this page now appears on 2nd Revised Page 16-51.9.

Transmittal No. 1676

Issued: October 17, 2022

Effective: November 1, 2022

Senior Director - Access Tariff Cost Development
60 Columbia Road, Bldg. A - 2nd Fl., Morristown, NJ 07960

ACCESS SERVICE

16. Public Packet Data Network (Cont'd)

16.3 Ethernet Transport Service (Cont'd)

16.3.4 Rate Regulations (Cont'd)

(A) Rate Categories (Cont'd)

(6) Optional Features and Functions (Cont'd)

(c) ETS Bandwidth Add-On (ETS BAO) (Cont'd)

When an ETS BAO feature is added at the same time as the underlying ETS rate element is initially installed, an Access Order Charge and nonrecurring charge associated with the underlying ETS rate element would apply. When an ETS BAO feature is subsequently added to an existing ETS rate element, an ETS Design Change Charge would apply per ETS BAO feature established by the Telephone Company as described in Section 16.3.4(B) (2) (d), below.

When ordering an ETS BAO feature, the ETS customer must specify on its Access Order: 1) each eligible ETS rate element and speed option combination to be supplemented using the ETS BAO feature and 2) the total number of 10 Mbps or 500 Mbps increments to be included in each ETS BAO feature. For example, an ETS customer requires an additional 20 Mbps of bandwidth capacity on its existing 50 Mbps ETS Interswitch EVC. On its Access Order to the Telephone Company, the ETS customer would identify the ETS Basic Ports between which the existing 50 Mbps ETS Interswitch EVC exists and order one ETS BAO feature made up of two 10 Mbps increments for that ETS EVC.

(C)

Transmittal No. 1561

Issued: November 16, 2018

Effective: December 1, 2018

Director - Access Tariffs
80 So. Jefferson Road, Whippany, NJ 07981

ACCESS SERVICE

16. Public Packet Data Network (Cont'd)

16.3 Ethernet Transport Service (Cont'd)

16.3.4 Rate Regulations (Cont'd)

(A) Rate Categories (Cont'd)

(6) Optional Features and Functions (Cont'd)

(c) ETS Bandwidth Add-On (ETS BAO) (Cont'd)

In addition to the applicable monthly charge for the underlying ETS rate element, a monthly charge applies for each ETS BAO feature established by the Telephone Company. The monthly charge is based upon the total number of 10 Mbps or 500 Mbps increments included in each ETS BAO feature ordered by the ETS customer. For example, an ETS customer orders two ETS BAO features to provide an additional 1 Gbps of bandwidth capacity on its existing 1 Gbps ETS Basic Port and associated 1 Gbps ETS CT. In addition to the monthly charges for the underlying 1 Gbps ETS Basic Port and associated 1 Gbps ETS CT, the Telephone Company would bill the ETS customer one ETS BAO feature monthly charge equal to two times the 500 Mbps increment ETS BAO feature ETS Basic Port rate and a second ETS BAO feature monthly charge equal to two times the 500 Mbps increment ETS BAO feature ETS CT rate. The ETS customer would also be billed two ETS Design Change Charges for the two ETS BAO features established by the Telephone Company since the two ETS BAO features were being added to existing ETS rate elements.

(C)
(C)
(C)
(C)
(C)
(C)
(C)
(C)
(C)
(C)

Transmittal No. 1561

Issued: November 16, 2018

Effective: December 1, 2018

Director - Access Tariffs
80 So. Jefferson Road, Whippany, NJ 07981

ACCESS SERVICE

16. Public Packet Data Network (Cont'd)

16.3 Ethernet Transport Service (Cont'd)

16.3.4 Rate Regulations (Cont'd)

(A) Rate Categories (Cont'd)

(6) Optional Features and Functions (Cont'd)

(c) ETS Bandwidth Add-On (ETS BAO) (Cont'd)

When an ETS customer adds an ETS BAO feature to an eligible ETS Basic Port equipped with the DSL Access Service Connection function and/or ETS Port Protection feature, the bandwidth capacity of the associated DSL Access Service Connection function and/or ETS Port Protection feature will be automatically supplemented by the bandwidth capacity ordered in the ETS BAO feature added to the underlying ETS Basic Port. The Telephone Company will only bill the ETS customer for the ETS BAO feature associated with the underlying ETS Basic Port.

As specified in Sections 16.3.5 and 16.3.6, following, the ETS BAO feature is eligible for an ETS Term Discount discount when the ETS BAO feature's underlying ETS rate element is associated with a committed ETS Port. Bandwidth capacity added to an eligible ETS Basic Port committed under the ETS Term Discount Plan or ETS Port Term Discount Plan using the ETS BAO feature does not change the ETS customer's term plan commitment on the originally committed ETS Basic Port.

Transmittal No. 1532

Issued: November 16, 2017

Effective: December 1, 2017

Director - Access Tariffs
80 So. Jefferson Road, Whippany, NJ 07981

ACCESS SERVICE

(N)

16. Public Packet Data Network (Cont'd)

16.3 Ethernet Transport Service (Cont'd)

16.3.4 Rate Regulations (Cont'd)

(A) Rate Categories (Cont'd)

(6) Optional Features and Functions (Cont'd)

(c) ETS Bandwidth Add-On (ETS BAO) (Cont'd)

When an ETS customer elects to change the bandwidth capacity of an existing ETS BAO feature or remove an existing ETS BAO feature from its underlying ETS rate element, an ETS Design Change Charge will apply, as described in Section 16.3.4(B)(2)(d), below. When an ETS customer disconnects an underlying ETS rate element equipped with an ETS BAO feature, the ETS BAO feature is automatically disconnected and neither an Access Order Charge nor an ETS Design Change Charge will apply for the disconnected ETS rate elements.

Rates and charges are specified in Section 17.4.8(C)(6)(d), following, or when applicable, as specified in Section 17.4.8(C)(9), following. The Telephone Company specific rate band assignment for the ETS Bandwidth Add-On optional feature is specified in the Ethernet Transport Service (ETS) column in Section 17.5.1, following, or when applicable, as specified in Section 17.4.8(C)(9), following.

(N)

Transmittal No. 1465

Issued: September 16, 2015

Effective: October 1, 2015

Director - Access Tariffs
80 So. Jefferson Road, Whippany, NJ 07981

ACCESS SERVICE

16. Public Packet Data Network (Cont'd)16.3 Ethernet Transport Service (Cont'd)16.3.4 Rate Regulations (Cont'd)(B) Types of Rates and Charges

There are two types of rates and charges. They are monthly rates and nonrecurring charges. The rates and charges are described below:

(1) Monthly Rates

Monthly rates are recurring rates that apply each month or fraction thereof when an ETS service element is provided. For billing purposes, each month is considered to have 30 days.

(2) Nonrecurring Charges

Nonrecurring charges are one-time charges that apply for specific work activity (i.e., installation or change to an existing service). The types of nonrecurring charges that apply for ETS are installation of service, service rearrangements, moves and design changes.

Except as specified below, these charges are in addition to the Access Order Charge as specified in Section 17.4.1, following.

(a) Installation of Service

Nonrecurring charges apply for installation of ETS CTs, ETS Ports, ETS EVCs, ETS E-EVCs, ETS I-EVCs and ETS Optional Features and Functions ordered by the ETS customer. (C)

Certain material previously found on this page now appears on 1st Revised Page 16-53.

Transmittal No. 1273

Issued: April 30, 2010

Effective:

August 18, 2010

Director - Access Tariffs
80 So. Jefferson Road, Whippany, NJ 07981

ACCESS SERVICE

16. Public Packet Data Network (Cont'd)

16.3 Ethernet Transport Service (Cont'd)

16.3.4 Rate Regulations (Cont'd)

(B) Types of Rates and Charges (Cont'd)

(2) Nonrecurring Charges (Cont'd)

(b) Service Rearrangements

Service rearrangements are changes to existing (i.e., installed) services, which may be administrative only in nature as set forth below or, that involve an actual physical change to the service.

When the ETS customer elects to replace an existing ETS Port or ETS CT with a new ETS Port or ETS CT, with a lower bandwidth capacity element than the existing ETS element being replaced, the request will be considered a discontinuance of service for the former capacity and start of service for the new capacity. Associated nonrecurring (i.e., installation) charges will apply, including any nonrecurring charges for optional features and functions, if applicable. New minimum period requirements will be established for the new ETS elements. The ETS customer will also remain responsible for satisfying all outstanding minimum period charges for the discontinued ETS elements.

(C)

(C)

(C)

(C)

Transmittal No. 1465

Issued: September 16, 2015

Effective: October 1, 2015

Director - Access Tariffs
80 So. Jefferson Road, Whippany, NJ 07981

ACCESS SERVICE

16. Public Packet Data Network (Cont'd)

16.3 Ethernet Transport Service (Cont'd)

16.3.4 Rate Regulations (Cont'd)

(B) Types of Rates and Charges (Cont'd)

(2) Nonrecurring Charges (Cont'd)

(b) Service Rearrangements (Cont'd)

When the ETS customer elects to replace an existing ETS Port or ETS CT with a new ETS Port or ETS CT with a higher bandwidth capacity element than the existing ETS element being replaced, the ETS Design Change Charge described in (d), below, will apply per new ETS element. New minimum period requirements will be established for the higher capacity ETS elements. Any outstanding minimum period charges associated with the lower capacity ETS elements being replaced that would otherwise be applicable as described in this paragraph will be waived. Nonrecurring charges will also be waived.

(C)
|
(C)
(C)

(C)
(C)

Transmittal No. 1465

Issued: September 16, 2015

Effective: October 1, 2015

Director - Access Tariffs
80 So. Jefferson Road, Whippany, NJ 07981

ACCESS SERVICE

16. Public Packet Data Network (Cont'd)

16.3 Ethernet Transport Service (Cont'd)

16.3.4 Rate Regulations (Cont'd)

(B) Types of Rates and Charges (Cont'd)

(2) Nonrecurring Charges (Cont'd)

(b) Service Rearrangements (Cont'd)

When the ETS customer elects to replace an existing ETS Basic Port equipped with the ETS Port Protection feature with a new ETS Basic Port equipped with the ETS Port Protection feature with a higher bandwidth capacity than the existing ETS Basic Port being replaced, an ETS Design Change Charge as described in (d), below, will apply for the new ETS Basic Port as described in the preceding paragraph and a second ETS Design Change Charge will apply per ETS Basic Port Protection feature in lieu of the ETS Port Protection nonrecurring charge.

(C)
|
(C)

For example, if an ETS customer elected to replace its existing 50 Mbps ETS CT and 50 Mbps ETS Basic Port equipped with the ETS Port Protection feature with a new 100 Mbps ETS CT and 100 Mbps ETS Basic Port equipped with the ETS Port Protection feature, three ETS Design Change Charges would apply.

(C)
|
(C)

When the ETS customer elects to replace an existing ETS EVC, ETS E-EVC, ETS I-EVC, ETS MM-VCC and/or ETS LBR-VCC with a new higher or lower bandwidth capacity ETS EVC, ETS E-EVC, ETS I-EVC, ETS MM-VCC and/or ETS LBR-VCC, respectively, the ETS Design Change Charge described in (d), below, will apply per ETS element changed.

(C)
|
(C)

Transmittal No. 1465

Issued: September 16, 2015

Effective: October 1, 2015

Director - Access Tariffs
80 So. Jefferson Road, Whippany, NJ 07981

ACCESS SERVICE

16. Public Packet Data Network (Cont'd)

16.3 Ethernet Transport Service (Cont'd)

16.3.4 Rate Regulations (Cont'd)

(B) Types of Rates and Charges (Cont'd)

(2) Nonrecurring Charges (Cont'd)

(b) Service Rearrangements (Cont'd)

When the ETS customer elects to remove existing ETS EVCs, ETS E-EVCs, and/or ETS I-EVCs, the ETS Design Change Charge described in (d), below, will apply per ETS EVC, ETS E-EVC or ETS I-EVC removed.

The ETS Design Change Charge will apply per ETS EVC, as described in (d), below, when an ETS customer elects to make one or more of the following changes on an existing ETS EVC that has at least one CoS level already established: (1) changing the bandwidth capacity of an existing CoS level; (2) adding an additional CoS level; (3) replacing one type of CoS level with another type of CoS level; or (4) removing an existing CoS level from the associated ETS EVC. Only one ETS Design Change Charge will apply when more than one of the above changes is made to the same associated ETS EVC at the same time on the same access order.

(M)
|
(M)

Certain material currently found on this page previously appeared on 4th Revised Page 16-54.

Certain material previously found on this page can now be found on Original Page 16-54.2.

Transmittal No. 1380

Issued: April 8, 2013

Effective: April 23, 2013

Director - Access Tariffs
80 So. Jefferson Road, Whippany, NJ 07981

ACCESS SERVICE

16. Public Packet Data Network (Cont'd)16.3 Ethernet Transport Service (Cont'd)16.3.4 Rate Regulations (Cont'd)(B) Types of Rates and Charges (Cont'd)(2) Nonrecurring Charges (Cont'd)(b) Service Rearrangements (Cont'd)

When the ETS customer elects to remove an existing ETS MM-VCC from its associated ADSL or SDSL Access Service, the ETS Design Change Charge described in (d), below, will apply per ETS MM-VCC removed. (T)

When the ETS customer elects to remove an existing ETS LBR-VCC from its associated ADSL or SDSL Access Service, the ETS Design Change Charge described in (d), below, will apply per ETS LBR-VCC removed. (T)

When the ETS customer elects to install an ETS BAO feature on an existing qualifying ETS Basic Port, ETS CT, ETS EVC, ETS E-EVC and/or ETS I-EVC as described in Section 16.3.4(A)(6)(c), preceding, the ETS Design Change Charge as described in (d), below, will apply per ETS BAO feature established.

When the ETS customer elects to increase or decrease the bandwidth capacity on an existing ETS BAO feature associated with an underlying ETS Basic Port, ETS CT, ETS EVC, ETS E-EVC and/or ETS I-EVC, the ETS Design Change Charge as described in (d), below, will apply per ETS BAO feature changed.

When the ETS customer elects to remove an existing ETS BAO feature from its underlying ETS Basic Port, ETS CT, ETS EVC, ETS E-EVC and/or ETS I-EVC, the ETS Design Change Charge as described in (d), below, will apply per ETS BAO feature removed.

Transmittal No. 1690

Issued: April 14, 2023

Effective: April 29, 2023

Senior Director - Access Tariff Cost Development
60 Columbia Road, Bldg. A - 2nd Fl., Morristown, NJ 07960

ACCESS SERVICE

(N)

16. Public Packet Data Network (Cont'd)

16.3 Ethernet Transport Service (Cont'd)

16.3.4 (B) Types of Rates and Charges (Cont'd)

(2) Nonrecurring Charges (Cont'd)

(b) Service Arrangements (Cont'd)

Administrative changes will be made without charge(s) to the ETS customer. Administrative changes are as follows:

- Change of customer name,
- Change of customer or customer's end user premises address when the change of address is not a result of physical relocation of equipment,
- Change in billing data (name, address, or contact name or telephone number),
- Change of agency authorization,
- Change of customer circuit identification,
- Change of billing account number,
- Change of customer or customer's end user contact name or telephone number, and
- Change of jurisdiction

(N)

Transmittal No. 1157

Issued: February 2, 2007

Effective:

Director - Access Tariffs
80 So. Jefferson Road, Whippany, NJ 07981

ACCESS SERVICE

16. Public Packet Data Network (Cont'd)16.3 Ethernet Transport Service (Cont'd)16.3.4 (B) Types of Rates and Charges (Cont'd)(2) Nonrecurring Charges (Cont'd)(c) Moves

A move involves a change in the physical location of one of the following:

- The Point of Termination at the customer's premises
- The customer's premises

The charges for moving ETS elements are dependent on whether the move is to a different location within the same building, to a different building within the same SWC, or to a different building in a different SWC. The charges specified below apply in addition to any applicable charges for moving any applicable Special Access Services as specified in Section 7.2.3, preceding.

(i) Moves Within the Same Building

ETS Basic and Interconnection Ports, ETS EVCs, ETS E-EVCs, and ETS I-EVCs are not impacted when an ETS customer moves its Point of Termination to a different location within the same building. The charge for moving an ETS CT within the same building will be an amount equal to one half of the nonrecurring (i.e., installation) charge for the ETS CT. There will be no change in the minimum period requirements.

Transmittal No. 1273

Issued: April 30, 2010

Effective:

August 18, 2010

Director - Access Tariffs
80 So. Jefferson Road, Whippany, NJ 07981

ACCESS SERVICE

16. Public Packet Data Network (Cont'd)

16.3 Ethernet Transport Service (Cont'd)

16.3.4 (B) Types of Rates and Charges (Cont'd)

(2) Nonrecurring Charges (Cont'd)

(c) Moves (Cont'd)

(ii) Moves To a Different Building Within the Same SWC

ETS Basic and Interconnection Ports, ETS EVCs, ETS E-EVCs and ETS I-EVCs are not impacted when an ETS customer moves its Point of Termination to a different building within the same SWC. The move of an ETS CT will be treated as a discontinuance and start of service. Associated nonrecurring (i.e., installation) charges will apply. New minimum period requirements will be established for the new services. The ETS customer will also remain responsible for satisfying all outstanding minimum period charges for the discontinued service.

(iii) Moves to a Different Building in a Different SWC

A move to a different building in a different SWC will be treated as a discontinuance and

Certain material previously found on this page now appears on Original Page 16-57.1.

Transmittal No. 1355

Issued: July 27, 2012

Effective: August 11, 2012

ACCESS SERVICE

16. Public Packet Data Network (Cont'd)

(M)

16.3 Ethernet Transport Service (Cont'd)

16.3.4 (B) Types of Rates and Charges (Cont'd)

(2) Nonrecurring Charges (Cont'd)

(c) Moves (Cont'd)

(iii) Moves to a Different Building
in a Different SWC (Cont'd)

start of service of all associated ETS elements. Associated nonrecurring (i.e., installation) charges will apply, including the ETS Port Protection feature nonrecurring charge, if applicable. New minimum period requirements will be established for the new services. The ETS customer will also remain responsible for satisfying all outstanding minimum period charges for the discontinued service.

(C) (M)

(C) (M)

(M)

Certain material currently found on this page previously appeared on 1st Revised Page 16-57.

Transmittal No. 1355

Issued: July 27, 2012

Effective: August 11, 2012

Director - Access Tariffs
80 So. Jefferson Road, Whippany, NJ 07981

ACCESS SERVICE

16. Public Packet Data Network (Cont'd)

16.3 Ethernet Transport Service (Cont'd)

16.3.4 (B) Types of Rates and Charges (Cont'd)

(2) Nonrecurring Charges (Cont'd)

(d) ETS Design Changes

As described in (b), above, the ETS Design Change Charge specified in Section 17.4.8(C)(6)(a)(v), following, or when applicable, as specified in Section 17.4.8(C)(9), following, will apply when the ETS customer elects to:

- (1) replace an existing ETS EVC, ETS E-EVC, ETS I-EVC, ETS MM-VCC and/or ETS LBR-VCC with a new higher or lower bandwidth capacity ETS EVC, ETS E-EVC, ETS I-EVC, ETS MM-VCC and/or ETS LBR-VCC, respectively;
- (2) remove existing ETS EVCs, ETS E-EVCs, or ETS I-EVCs;
- (3) remove an existing ETS MM-VCC from its associated ADSL or SDSL Access Service;
- (4) remove an existing ETS LBR-VCC from its associated ADSL or SDSL Access Service;
- (5) replace an existing ETS Port or ETS CT with a new ETS Port or ETS CT with a higher bandwidth capacity element than the existing ETS element being replaced;
- (6) convert an existing One-Way ETS MM-VCC to a Two-Way ETS MM-VCC or vice versa;
- (7) add an ETS BAO feature to an existing ETS Basic Port, ETS CT, ETS EVC, ETS E-EVC and/or ETS I-EVC;
- (8) increase or decrease the bandwidth capacity on an existing ETS BAO feature associated with an underlying ETS Basic Port, ETS CT, ETS EVC, ETS E-EVC and/or ETS I-EVC; or
- (9) remove an existing ETS BAO feature from its underlying ETS Basic Port, ETS CT, ETS EVC, ETS E-EVC and/or ETS I-EVC.

Transmittal No. 1690

Issued: April 14, 2023

Effective: April 29, 2023

Senior Director - Access Tariff Cost Development
 60 Columbia Road, Bldg. A - 2nd Fl., Morristown, NJ 07960

ACCESS SERVICE

16. Public Packet Data Network (Cont'd)

16.3 Ethernet Transport Service (Cont'd)

16.3.4 (B) Types of Rates and Charges (Cont'd)

(2) Nonrecurring Charges (Cont'd)

(d) ETS Design Changes (Cont'd)

The ETS Design Change Charge will apply per ETS EVC when the ETS customer elects to: (1) change the bandwidth capacity of an existing CoS level; (2) add an additional CoS level; (3) replace one type of CoS level with another type of CoS level; or (4) remove an existing CoS level from the associated ETS EVC. Only one ETS Design Change Charge will apply when more than one of the above changes is made to the same associated ETS EVC at the same time on the same access order.

(M)

(M)

When applicable, the ETS Design Change Charge applies in lieu of the ETS EVC, ETS E-EVC, ETS I-EVC, ETS MM-VCC or ETS LBR-VCC nonrecurring charge.

The Access Order Charge will not apply when the ETS Design Change Charge is applicable.

(C) Minimum Periods

The minimum period for ETS service elements provided to an ETS customer and for which charges are applicable is:

- Twelve months for ETS Basic Ports, ETS Interconnection Ports, ETS Channel Terminations and
- One month for all other ETS elements.

Certain material currently found on this page previously appeared on 6th Revised Page 16-58.

Transmittal No. 1465

Issued: September 16, 2015

Effective: October 1, 2015

Director - Access Tariffs
80 So. Jefferson Road, Whippany, NJ 07981

ACCESS SERVICE

(N)

16. Public Packet Data Network (Cont'd)

16.3 Ethernet Transport Service (Cont'd)

16.3.4 Rate Regulations (Cont'd)

(D) Mixed Use

Mixed use refers to a rate applicable when the customer orders Ethernet Transport Service between its CDP and an ETS-equipped SWC when the same customer also orders a portion of the available bandwidth capacity on its ETS Basic Port at that SWC as Ethernet Switched Access Local Transport (ESALT).

Mixed use is only available at SWCs designated by the Telephone Company in NATIONAL EXCHANGE CARRIER ASSOCIATION, INC. Tariff F.C.C. No. 4 as being both ETS and ESALT equipped.

Where suitable facilities exist, mixed use arrangements are available when provided by the Telephone Company within its serving territory and when jointly provided by the Telephone Company with another telephone company in an adjacent or non-adjacent serving territory as described for ESALT in Section 6.1, preceding.

Mixed use arrangements are not available when the customer uses ETS Interconnection Ports and associated Special Access Services. Mixed use arrangements are also not available when jointly provided with another telephone company in a non-adjacent serving territory where the number of miles between the ETS SWC serving the customer's CDP and the ESALT SWC is greater than 75 airline miles.

(N)

Transmittal No. 1403

Issued: November 7, 2013

Effective: November 22, 2013

Director - Access Tariffs
80 So. Jefferson Road, Whippany, NJ 07981

ACCESS SERVICE

(N)

16. Public Packet Data Network (Cont'd)16.3 Ethernet Transport Service (Cont'd)16.3.4 Rate Regulations (Cont'd)(D) Mixed Use (Cont'd)

The initial facilities between the CDP and ETS-equipped SWC will be ordered, provided and rated as ETS (e.g., including where applicable based on its configuration, ETS Basic Ports, ETS Channel Terminations, ETS EVCs, optional features, etc.). The nonrecurring charges that apply when these components are installed will be the nonrecurring charges associated with the applicable ETS rate elements as specified in Section 17.4.8, following.

Rating as ETS will continue until such time as the customer places an order to activate a portion of the available ETS bandwidth capacity for use as ESALT. It is at this point the ETS facilities between the CDP and ETS-equipped SWC become mixed use subject to the following provisions.

As specified in Section 6.1, preceding, ESALT is available in increments of 2 Mbps, 10 Mbps and 50 Mbps. As each 2 Mbps, 10 Mbps or 50 Mbps increment of capacity on the customer's ETS Basic Port is activated for use as ESALT, the monthly rates for the applicable ETS rate elements for the shared mixed use facilities between the ETS/ESALT SWC and the CDP, excluding the monthly rate for the ETS Port Protection feature, will be reduced by a factor reflecting the capacity used for ESALT divided by the total capacity available on the mixed use facilities. The monthly rates for the ETS Port Protection feature and for other non-shared ETS rate elements used between the ETS/ESALT SWC and other locations will not be reduced by this adjustment factor.

(N)

Transmittal No. 1403

Issued: November 7, 2013

Effective: November 22, 2013

Director - Access Tariffs
80 So. Jefferson Road, Whippany, NJ 07981

ACCESS SERVICE

16. Public Packet Data Network (Cont'd)

16.3 Ethernet Transport Service (Cont'd)

16.3.4 Rate Regulations (Cont'd)

(D) Mixed Use (Cont'd)

For example, the customer orders 10 Mbps on its existing 100 Mbps ETS Basic Port, 100 Mbps ETS Channel Termination and ETS Port Protection feature activated for use as ESALT at the ETS/ESALT SWC serving the CDP. In this example, the adjustment factor used would be 10% (i.e., 10 Mbps/100 Mbps), which would be applied to the undiscounted monthly rates for the 100 Mbps ETS Basic Port and the 100 Mbps ETS Channel Termination. This adjustment factor would not be applied to the monthly rate for the ETS Port Protection feature or to any other non-shared ETS rate elements ordered by the customer to connect to other locations.

If the ETS monthly charges for the shared mixed use facilities are subject to an ETS Term Discount Plan or ETS Port Term Discount Plan discount as set forth in Sections 16.3.5 and 16.3.6, following, the ETS monthly charges for the shared ETS facilities will be reduced to reflect mixed use before any ETS Term Discount Plan or ETS Port Term Discount Plan discount is applied.

(C)
|
(C)
(C)
(C)

Switched Access Service rates and charges, as set forth in Section 17.2, following, will apply for each 2 Mbps, 10 Mbps or 50 Mbps increment of capacity on the customer's ETS Basic Port activated for use as ESALT. The Switched Access Service monthly rates for the ESALT components activated on shared mixed use ETS facilities will not be reduced to reflect mixed use and are not subject to any ETS Term Discount Plan or ETS Port Term Discount Plan discount.

(C)
(C)

Transmittal No. 1532

Issued: November 16, 2017

Effective: December 1, 2017

ACCESS SERVICE

(N)

16. Public Packet Data Network (Cont'd)

16.3 Ethernet Transport Service (Cont'd)

16.3.4 Rate Regulations (Cont'd)

(D) Mixed Use (Cont'd)

When the customer orders the activation of capacity of its existing ETS for use as ESALT, the customer must provide the information specified in Section 5.2.1(G), preceding, on its order. In addition to the applicable ESALT nonrecurring charges for the service components ordered, an Access Order Charge will apply per order. The customer may order multiple increments of capacity for use as ESALT on the same access order, in which case only one Access Order Charge will apply.

When the customer orders both ETS and ESALT installed at the same ETS/ESALT SWC at the same time, the Telephone Company will waive the Access Order Charge and associated ESALT nonrecurring charges that would otherwise apply for the service components ordered on the ESALT order provided the customer's ESALT and ETS orders cross reference each other. An Access Order Charge and associated ETS nonrecurring charges will apply for the service components ordered on the ETS order.

(N)

Transmittal No. 1403

Issued: November 7, 2013

Effective: November 22, 2013

Director - Access Tariffs
80 So. Jefferson Road, Whippany, NJ 07981

ACCESS SERVICE

16. Public Packet Data Network (Cont'd)

16.3 Ethernet Transport Service (Cont'd)

16.3.5 ETS Term Discount Plan

An optional term discount plan is available for Ethernet Transport Service (ETS). Under the ETS Term Discount Plan (ETS TDP), the monthly rates for eligible ETS service elements are reduced by a fixed percentage. The amount of the discount percentage differs based on the length of the term commitment period selected by the ETS customer. (T)

ETS may be ordered at the customer's option on a month-to-month basis, under an ETS TDP with a single term commitment period of either 36 months or 60 months as described herein, or under one or more individual ETS Port Term Discount Plans (ETS PTDPs) as described in Section 16.3.6, following. (C)

The customer must notify the Telephone Company in writing of the length of its selected term commitment period. For purposes of this plan, all ETS Basic and ETS Interconnection Ports included in a customer's ETS Term Discount Plan are referred to as committed ETS Ports. To be included in the ETS Term Discount Plan, all committed ETS Ports within the Telephone Company's operating territory must be ordered for the same term commitment period (i.e., all 36 months or all 60 months) and remain in-service at the same bandwidth capacity throughout the entire term commitment period. ETS Ports installed after the establishment of the customer's ETS Term Discount Plan may be ordered on a month-to-month basis, added as additional committed ETS Ports to a customer's existing ETS TDP term commitment period as described in (A), below, or ordered under individual ETS PTDPs as described in Section 16.3.6, following. (C)

Access Order Charges as described in Section 5.4.1, preceding, do not apply to establish a new or make any changes to an existing ETS Term Discount Plan. (C)

Transmittal No. 1532

Issued: November 16, 2017

Effective: December 1, 2017

ACCESS SERVICE

16. Public Packet Data Network (Cont'd)

16.3 Ethernet Transport Service (Cont'd)

16.3.5 ETS Term Discount Plan (Cont'd)

The monthly rates for ETS service elements are set forth in Sections 17.4.8(C)(1) through (C)(6), following, or when applicable, as specified in Section 17.4.8(C)(9), following. The term discount percentages for the ETS Term Discount Plan are set forth in Section 17.4.8(C)(7), following. The ETS Term Discount Plan is only available from those Telephone Companies listed in Section 17.3.10(A)(1), following.

The term discount percentage for the customer's selected term commitment period applies to all committed ETS Ports provided within the Telephone Company's operating territory. The term discount percentage also applies to the following eligible ETS elements when these elements are provided within the Telephone Company's operating territory and associated with a committed ETS Port: 1) ETS Channel Terminations (ETS CTs); 2) ETS Ethernet Virtual Connections (ETS EVCs) and associated Class of Service (CoS) levels, where applicable; 3) ETS Extended Ethernet Virtual Connections (ETS E-EVCs); 4) ETS Interconnected Ethernet Virtual Connections (ETS I-EVCs); 5) ETS MultiMedia Virtual Circuit Channels (ETS MM-VCCs); 6) ETS Low Bit Rate Virtual Circuit Channels (ETS LBR-VCCs); 7) the ETS Bandwidth Add-On (ETS BAO) feature; (C)
 and 8) the ETS Port Protection feature. Since there (C)
 are no bandwidth or in-service requirements for ETS CTs, ETS EVCs, ETS E-EVCs, ETS I-EVCs, ETS MM-VCCs, ETS LBR-VCCs, ETS BAO features and ETS Port Protection (C)
 features associated with committed ETS Ports under the (C)
 ETS Term Discount Plan, customer ordered disconnects of or changes to the number or bandwidth capacities for these elements do not affect the customer's ETS Term Discount Plan.

Transmittal No. 1465

Issued: September 16, 2015

Effective: October 1, 2015

Director - Access Tariffs
 80 So. Jefferson Road, Whippany, NJ 07981

ACCESS SERVICE

16. Public Packet Data Network (Cont'd)

16.3 Ethernet Transport Service (Cont'd)

16.3.5 ETS Term Discount Plan

When an eligible ETS element (i.e., ETS EVCs and associated CoS levels, ETS E-EVCs, ETS I-EVCs, and the ETS BAO) is ordered between a committed ETS TDP Port and a committed ETS Port Term Discount Plan (ETS PTDP) Port that have different term commitment lengths (e.g., an ETS TDP Port committed for 60 months and an ETS PTDP Port committed for 36 months), the Telephone Company will apply the discount percentage associated with the longer term commitment length (in this example the 60 month commitment) to such eligible ETS element.

(C)
(C)

Transmittal No. 1539

Issued: February 14, 2018

Effective: March 1, 2018

Director - Access Tariffs
80 So. Jefferson Road, Whippany, NJ 07981

ACCESS SERVICE

16. Public Packet Data Network (Cont'd)

16.3 Ethernet Transport Service (Cont'd)

16.3.5 ETS Term Discount Plan (Cont'd)

The ETS TDP term discount percentage does not apply (T)
to: 1) ETS Ports ordered on a month-to-month basis or (C)
committed under an ETS PTDP term commitment; 2) ETS (C)
CTs, ETS EVCs and associated CoS levels, where
applicable, ETS E-EVCs, ETS I-EVCs, ETS MM-VCCs, ETS
LBR-VCCs, ETS BAO features, and ETS Port Protection
features that are not associated with a committed ETS (T)
TDP Port; 3) ETS nonrecurring charges; and 4) special
access services connected to an ETS Interconnection
Port.

Except as specified in (A)-(C), below, discontinuance
charges will apply when the customer fails to satisfy
the term commitment period or the in-service
requirements for its committed ETS Ports.

The term discount percentage set forth in
Section 17.4.8(C)(7), following, will not be subject
to Telephone Company initiated decreases during the
customer's selected term commitment period.

If a term discount percentage increase occurs during
the term of an existing ETS Term Discount Plan, the
increased percentage will be applied automatically for
the remainder of the customer's existing term
commitment period.

Certain material formerly found on this page now appears on Original Page 16-61.1.

Transmittal No. 1532

Issued: November 16, 2017

Effective: December 1, 2017

Director - Access Tariffs
80 So. Jefferson Road, Whippany, NJ 07981

ACCESS SERVICE

16. Public Packet Data Network (Cont'd)

16.3 Ethernet Transport Service (Cont'd)

16.3.5 ETS Term Discount Plan (Cont'd)

At the end of the term commitment period, the customer may subscribe to a new ETS Term Discount Plan commitment period provided the customer had not previously subscribed to an ETS PTDP, subscribe to individual ETS PTDPs as described in Section 16.3.6, following, or revert to the undiscounted monthly rates and nonrecurring charges specified in Sections 17.4.8(C)(1) through (C)(6), following. If the customer does not notify the Telephone Company in writing of its choice by the end of its existing term commitment period, the Telephone Company will automatically convert the customer's ETS billing to the undiscounted monthly rates and nonrecurring charges specified in Sections 17.4.8(C)(1) through (C)(6), following. An Access Order Charge will not apply when a customer at the end of its existing term commitment period subscribes to a replacement ETS Term Discount Plan, subscribes to individual ETS PTDPs as described in Section 16.3.6, following, or reverts to month-to-month rates.

(N)

(N)

(M)

(C)

(C)

(M)

Certain material currently found on this page previously appeared on 6th Revised Page 16-61.

Transmittal No. 1532

Issued: November 16, 2017

Effective: December 1, 2017

Director - Access Tariffs
80 So. Jefferson Road, Whippany, NJ 07981

ACCESS SERVICE

16. Public Packet Data Network (Cont'd)

16.3 Ethernet Transport Service (Cont'd)

16.3.5 ETS Term Discount Plan (Cont'd)

(A) ETS Port Additions

An ETS Term Discount Plan customer will choose one of the following options when ordering a new ETS Port during its existing term commitment period:

- (1) Add the new ETS Port to its existing ETS Term Discount Plan provided the customer commits to retain the newly installed ETS Port in-service at the same bandwidth capacity for the remainder of the existing term commitment period. The term commitment period of the customer's existing ETS Term Discount Plan will continue uninterrupted.
- (2) Order the new ETS Port on a month-to-month basis. No term discount percentage would apply to the newly installed ETS Port. The term commitment period of the customer's existing ETS Term Discount Plan will continue uninterrupted.
- (3) Add the new ETS Port under a new individual ETS PTDP as described in Section 16.3.6, following.
- (4) Replace the existing ETS Term Discount Plan in its entirety with a new ETS Term Discount Plan as described in (C), below, provided the customer had not previously subscribed to an ETS PTDP.

(T)
(C)
|
(C)

Transmittal No. 1589

Issued: October 17, 2019

Effective: November 1, 2019

Director - Access Tariffs
80 So. Jefferson Road, Whippany, NJ 07981

ACCESS SERVICE

16. Public Packet Data Network (Cont'd)16.3 Ethernet Transport Service (Cont'd)16.3.5 ETS Term Discount Plan (Cont'd)(B) Committed ETS Port Replacements

An ETS Term Discount Plan customer will choose one of the following options when replacing a committed ETS Port during its existing term commitment period:

- (1) An ETS Term Discount Plan customer may disconnect a committed ETS Port before the end of its existing term commitment period and replace it with one or more newly installed committed ETS Port(s) under its existing ETS TDP term commitment without the application of a discontinuance charge as described in (D), below, provided: 1) the bandwidth capacity of the replacement committed ETS Port(s) is equal to or greater than the bandwidth capacity of the disconnected committed ETS Port; 2) the customer commits to retain the replacement committed ETS Port(s) in-service at the same bandwidth capacity for the remainder of the existing term commitment period; and 3) the customer's orders for the disconnect of the originally committed ETS Port and installation of the replacement committed ETS Port(s) are submitted to the Telephone Company at the same time and include cross references as described in Section 5.2.8(B), preceding.

(C)

If the bandwidth capacity of the newly installed committed ETS Port(s) is less than the bandwidth capacity of the disconnected committed ETS Port, the disconnected

Transmittal No. 1589

Issued: October 17, 2019

Effective: November 1, 2019

Director - Access Tariffs
80 So. Jefferson Road, Whippany, NJ 07981

ACCESS SERVICE

16. Public Packet Data Network (Cont'd)

16.3 Ethernet Transport Service (Cont'd)

16.3.5 ETS Term Discount Plan (Cont'd)

(B) Committed ETS Port Replacements (Cont'd)

committed ETS Port will be subject to a discontinuance charge as described in (D), below. The newly installed port(s) can be added as a committed ETS Port to the existing term commitment period or ordered on a month-to-month basis as described in (A), above.

(D)

(D)

(2) An ETS Term Discount Plan customer may disconnect a committed ETS TDP Port before the end of its existing term commitment period and replace it with a newly installed committed ETS PTDP Port under a new 36 or 60 month individual ETS PTDP commitment as described in Section 16.3.6, following. The newly committed replacement ETS PTDP Port may be at any available bandwidth capacity and any location within the Telephone Company's operating territory. The Telephone Company will waive any ETS TDP discontinuance charge as described in (D), below, and any unsatisfied minimum service period charge as described in Section 16.3.4(C), preceding, that may otherwise be applicable provided

Transmittal No. 1589

Issued: October 17, 2019

Effective: November 1, 2019

Director - Access Tariffs
80 So. Jefferson Road, Whippany, NJ 07981

ACCESS SERVICE

(N)

16. Public Packet Data Network (Cont'd)16.3 Ethernet Transport Service (Cont'd)16.3.5 ETS Term Discount Plan (Cont'd)(B) (2) Committed ETS Port Replacements (Cont'd)

the customer's orders for the disconnect of the originally committed ETS TDP Port under its ETS TDP term commitment and installation of the newly committed replacement ETS PTDP Port under its new ETS PTDP term commitment are submitted to the Telephone Company at the same time and include cross references as described in Section 5.2.8(C), preceding.

After a committed ETS TDP Port has been disconnected and replaced with a committed ETS PTDP Port any committed ETS Ports remaining in the customer's ETS TDP term commitment may: (1) remain in-service under the ETS TDP until the end of the term commitment period, (2) be disconnected at any time during the ETS TDP term commitment period, or (3) be converted to undiscounted monthly rates and nonrecurring charges.

Once a customer subscribes to an ETS PTDP, it is no longer eligible to subscribe to a new ETS TDP once its existing ETS TDP term commitment period expires.

- (3) An ETS Term Discount Plan customer may transfer an in-service committed ETS Port before the end of its existing term commitment period to a new 36 or 60 month individual ETS Port Term Discount Plan. The transferred committed ETS PDTP Port will remain in-service at the same bandwidth capacity and same location as the previously committed ETS TDP Port.

(N)

Transmittal No. 1532

Issued: November 16, 2017

Effective: December 1, 2017

Director - Access Tariffs
80 So. Jefferson Road, Whippany, NJ 07981

ACCESS SERVICE

16. Public Packet Data Network (Cont'd)

16.3 Ethernet Transport Service (Cont'd)

16.3.5 ETS Term Discount Plan (Cont'd)

(B) (3) Committed ETS Port Replacements (Cont'd)

An Access Order Charge will not apply to the customer's order for the transfer of the in-service committed ETS TDP Port to an individual ETS PTDP term commitment. The Telephone Company will waive any ETS TDP discontinuance charge as described in (D), below, and any unsatisfied minimum service charge as described in Section 16.3.4(C), preceding, that may otherwise be applicable.

(4) An E-rate eligible school, library or consortium may transfer an in-service committed ETS Port before the end of its existing ETS Term Discount Plan commitment period to its ETS E-Rate Option (ETS ERO) commitment without the application of a discontinuance charge as described in (D), below. An Access Order Charge will not apply to the customer's order for the transfer of an in-service ETS Term Discount Plan Committed Port to the customer's ETS ERO commitment. Availability of and eligibility for the ETS ERO are as specified in Section 16.3.8, following.

(5) An eligible rural health care provider may transfer an in-service committed ETS Port before the end of its existing ETS Term Discount Plan commitment period to its ETS Rural Health Care-Rate Option (ETS RHC-RO) commitment without the application of a discontinuance charge as described in (D), below. An Access Order Charge will not apply to the customer's order for the transfer of an in-service ETS Term Discount Plan Committed Port to the customer's ETS RHC-RO commitment. Availability of and eligibility for the ETS RHC-RO are as specified in Section 16.3.9, following.

(N)

(N)

Transmittal No. 1646

Issued: October 15, 2021

Effective: October 30, 2021

Director - Access Tariff Development
60 Columbia Road, Bldg. A - 2nd Fl., Morristown, NJ 07960

ACCESS SERVICE

16. Public Packet Data Network (Cont'd)

16.3 Ethernet Transport Service (Cont'd)

16.3.5 ETS Term Discount Plan (Cont'd)

(C) ETS Term Discount Plan Replacements

An ETS Term Discount Plan customer will choose one of the following options when replacing its existing ETS TDP during its existing term commitment period:

(N)
|
(N)

- (1) The customer may replace an existing ETS Term Discount Plan in its entirety with a new ETS Term Discount Plan without the application of a discontinuance charge as described in (D), below, provided: 1) the term commitment period of the new ETS Term Discount Plan meets or exceeds the number of months remaining in the customer's existing ETS term commitment period and 2) the bandwidth capacity of the committed ETS Ports under the new ETS Term Discount Plan meets or exceeds the bandwidth capacity of the committed ETS Ports in the customer's existing ETS term commitment period. The term discount percentage applicable for the replacement ETS Term Discount Plan will apply on a going forward basis based on the customer's written request to establish a new ETS Term Discount Plan commitment period under this provision.

Transmittal No. 1532

Issued: November 16, 2017

Effective: December 1, 2017

Director - Access Tariffs
80 So. Jefferson Road, Whippany, NJ 07981

ACCESS SERVICE

16. Public Packet Data Network (Cont'd)

16.3 Ethernet Transport Service (Cont'd)

16.3.5 ETS Term Discount Plan (Cont'd)

(C) (1) ETS Term Discount Plan Replacements (Cont'd)

(T)

For example, a customer with an existing 36 month term commitment period and 50 Mbps of bandwidth capacity for its committed ETS Ports can replace that term commitment in its entirety with a new 36 month or 60 month term commitment period at any time during the existing term commitment period without the application of a discontinuance charge provided the bandwidth capacity of the customer's committed ETS Ports under the new term commitment period is at least 50 Mbps.

When the term commitment period of a replacement ETS Term Discount Plan does not meet or exceed the number of months remaining in the customer's existing ETS Term Discount Plan commitment period, a discontinuance charge as described in (D), below, will apply.

(T)

Transmittal No. 1532

Issued: November 16, 2017

Effective: December 1, 2017

Director - Access Tariffs
80 So. Jefferson Road, Whippany, NJ 07981

ACCESS SERVICE

16. Public Packet Data Network (Cont'd)

16.3 Ethernet Transport Service (Cont'd)

16.3.5 ETS Term Discount Plan (Cont'd)

(C) (1) ETS Term Discount Plan Replacements (Cont'd)

(T)

When the term commitment period of the new ETS Term Discount Plan meets or exceeds the number of months remaining in the customer's existing ETS term commitment period, but the bandwidth capacity of the customer's committed ETS Ports under the new term commitment period is less than the bandwidth capacity of the committed ETS Ports under the customer's existing term commitment period, the following provisions will apply.

(T)

- (a) When the total monthly undiscounted charges for the number and type of committed ETS Ports to be included in the customer's replacement ETS Term Discount Plan is equal to or greater than the total monthly undiscounted charges for the number and type of committed ETS Ports included in the customer's existing ETS Term Discount Plan, the customer will be permitted to replace its existing ETS Term Discount Plan without the application of either a discontinuance charge as described in (D), below, or a commitment shortfall charge as described in (b), below.

Transmittal No. 1532

Issued: November 16, 2017

Effective: December 1, 2017

ACCESS SERVICE

16. Public Packet Data Network (Cont'd)

16.3 Ethernet Transport Service (Cont'd)

16.3.5 ETS Term Discount Plan (Cont'd)

(C) (1) ETS Term Discount Plan Replacements (Cont'd) (T)

(b) When the total monthly undiscounted charges for the number and type of committed ETS Ports to be included in the customer's replacement ETS Term Discount Plan is less than the total monthly undiscounted charges for the number and type of committed ETS Ports included in the customer's existing ETS Term Discount Plan, the customer will be permitted to replace its existing ETS Term Discount Plan under this provision, however, a commitment shortfall charge will apply. The commitment shortfall charge will apply in lieu of a discontinuance charge as described in (D), below, and will be calculated as follows:

Step 1: Determine the difference between the total monthly undiscounted charges for the number and type of committed ETS Ports included in the customer's existing ETS Term Discount Plan and the total monthly undiscounted charges for the number and type of committed ETS Ports to be included in the customer's replacement ETS Term Discount Plan.

Transmittal No. 1532

Issued: November 16, 2017

Effective: December 1, 2017

Director - Access Tariffs
80 So. Jefferson Road, Whippany, NJ 07981

ACCESS SERVICE

16. Public Packet Data Network (Cont'd)16.3 Ethernet Transport Service (Cont'd)16.3.5 ETS Term Discount Plan (Cont'd)(C) (1) (b) ETS Term Discount Plan Replacements (Cont'd)

(T)

Step 2: Multiply the result from Step 1 by 35%.

Step 3: Multiply the result from Step 2 times the number of months remaining in the existing term commitment period.

For example, a customer elects to replace its existing 36 month ETS Term Discount Plan in its entirety in the 22nd month of the existing term commitment period with a new 36 month ETS Term Discount Plan. The existing term plan commitment includes a total bandwidth capacity requirement of 300 Mbps for the customer's six 50 Mbps committed ETS Basic Ports. In the replacement ETS Term Discount Plan, the customer will only be including two 100 Mbps committed ETS Basic Ports for a total bandwidth capacity of 200 Mbps. Although the customer satisfies the term commitment length replacement requirement with the new ETS Term Discount Plan, it does not satisfy the bandwidth capacity replacement requirement and the total monthly undiscounted charges under the new term commitment period are less than the total monthly undiscounted charges under the existing term commitment period.

Transmittal No. 1532

Issued: November 16, 2017

Effective: December 1, 2017

Director - Access Tariffs
80 So. Jefferson Road, Whippany, NJ 07981

ACCESS SERVICE

16. Public Packet Data Network (Cont'd)

16.3 Ethernet Transport Service (Cont'd)

16.3.5 ETS Term Discount Plan (Cont'd)

(C) (1) (b) ETS Term Discount Plan Replacements (Cont'd)

(T)

Using illustrative undiscounted monthly rates of \$275.00 for a 50 Mbps ETS Basic Port and \$330.00 for a 100 Mbps ETS Basic Port, the Telephone Company would bill the customer a commitment shortfall charge totaling \$4,851.00 based on:

Step 1: \$1,650.00 (i.e., \$275.00 x 6 ports)
 - \$660.00 (i.e., \$330.00 x 2 ports) =
 \$990.00

Step 2: \$990.00 x 35% = \$346.50

Step 3: \$346.50 x 14 months = \$4,851.00

(2) The customer may discontinue its existing ETS TDP in its entirety at any time during the term commitment period and replace it with one or more individual ETS PTDPs under new 36 and/or 60 month term commitment periods as described in Section 16.3.6, following. The replacement committed ETS PTDP Ports may be at any available bandwidth capacity and any location within the Telephone Company's operating territory. Any committed ETS TDP Ports not transferred to individual ETS PTDPs will be disconnected. The Telephone Company will waive any ETS TDP discontinuance charges as described in (D), below, and any unsatisfied minimum service period charges as described in Section 16.3.4(C), preceding, that may otherwise be applicable provided the customer's orders for the discontinuance of the ETS TDP (including the disposition of each committed ETS TDP Port) and the replacement ETS PTDPs are submitted to the Telephone Company at the same time and include cross references as described in Section 5.2.8(D), preceding.

(N)

Once the customer replaces its existing ETS TDP with one or more replacement ETS PTDPs, it is no longer eligible to subscribe to a new ETS TDP.

(N)

Certain material formerly found on this page now appears on Original Page 16-70.1.

Transmittal No. 1532

Issued: November 16, 2017

Effective: December 1, 2017

Director - Access Tariffs
 80 So. Jefferson Road, Whippany, NJ 07981

ACCESS SERVICE

(N)

16. Public Packet Data Network (Cont'd)16.3 Ethernet Transport Service (Cont'd)16.3.5 ETS Term Discount Plan (Cont'd)(D) Discontinuance Charges (Cont'd)

The discontinuance charge will be equal to 35% of the total undiscounted monthly rate for each committed ETS Port included in the customer's ETS Term Discount Plan for each month remaining in the unsatisfied term commitment period. Minimum service period charges as specified in Section 16.3.4(C), preceding, would also apply, if applicable.

The following examples illustrate how the Telephone Company will calculate the applicable discontinuance charge.

Example 1

A customer discontinues its existing ETS Term Discount Plan in its entirety in the 20th month of a 36 month term commitment period. The customer included three 100 Mbps committed ETS Basic Ports when it established its initial term plan commitment.

Using an illustrative undiscounted monthly rate of \$330.00 for a 100 Mbps ETS Basic Port, the Telephone Company would bill the customer a term plan discontinuance charge totaling \$5,544.00 (i.e., \$330.00 x 35% x 3 ports x 16 months).

(N)

Transmittal No. 1202

Issued: March 17, 2008

Effective: July 10, 2008

Director - Access Tariffs
80 So. Jefferson Road, Whippany, NJ 07981

ACCESS SERVICE

(N)

16. Public Packet Data Network (Cont'd)

16.3 Ethernet Transport Service (Cont'd)

16.3.5 ETS Term Discount Plan (Cont'd)

(D) Discontinuance Charges (Cont'd)

Example 2

A customer disconnects one of the four 50 Mbps committed ETS Basic Ports included in its ETS Term Discount Plan in the 39th month of a 60 month term commitment period. The customer included all four of these ports when it established its initial term plan commitment.

Using an illustrative undiscounted monthly rate of \$275.00 for a 50 Mbps ETS Basic Port, the Telephone Company would bill the customer a port discontinuance charge totaling \$2,021.25 (i.e., \$275.00 x 35% x 21 months).

(N)

Transmittal No. 1202

Issued: March 17, 2008

Effective: *July 10, 2008*

Director - Access Tariffs
80 So. Jefferson Road, Whippany, NJ 07981

ACCESS SERVICE

16. Public Packet Data Network (Cont'd)

16.3 Ethernet Transport Service (Cont'd)

16.3.5 ETS Term Discount Plan (Cont'd)

(E) ETS Volume Discount Plan (Cont'd)

The ETS VDP discount does not apply to: (1) ETS Ports ordered on a month-to-month basis or committed under an ETS PTDP term commitment (i.e., non-committed ETS TDP Ports), (2) any other ETS monthly charges, (3) any ETS nonrecurring charges, or (4) any monthly or nonrecurring charges for special access services connected to a committed ETS Interconnection Port.

Access Order Charges as described in Section 5.4.1, preceding, do not apply to establish a new ETS VDP or to terminate an existing ETS VDP.

The ETS VDP discount is specified in Section 17.4.8(C)(8), following.

Transmittal No. 1532

Issued: November 16, 2017

Effective: December 1, 2017

Director - Access Tariffs
80 So. Jefferson Road, Whippany, NJ 07981

ACCESS SERVICE

16. Public Packet Data Network (Cont'd)16.3 Ethernet Transport Service (Cont'd)16.3.6 ETS Port Term Discount Plan

An optional term discount plan is available for Ethernet Transport Service (ETS). Under the ETS Port Term Discount Plan, the monthly rates for eligible ETS service elements are reduced by a fixed percentage. The amount of the discount percentage differs based on the length of the term commitment period selected by the ETS customer.

ETS may be ordered at the ETS customer's option on an undiscounted month-to-month basis, under a single ETS Term Discount Plan (ETS TDP) as described in Section 16.3.5, preceding, or under individual ETS Port Term Discount Plans (ETS PTDPs) as described herein.

Each individual ETS PTDP is associated with a single ETS PTDP Port provided within the Telephone Company's operating territory for the selected 36 or 60 month term commitment period. An ETS Basic or Interconnection Port included in an ETS PTDP is referred to as a committed ETS Port. The monthly rate for the committed ETS Port is reduced by a fixed percentage. The amount of the percentage discount differs based on the term commitment length selected by the ETS customer for that ETS PTDP term commitment.

The ETS customer may subscribe to an unlimited number of ETS PTDPs. When placing an order for a committed ETS PTDP Port, the customer must specify in writing the length of the selected ETS PTDP term commitment. A committed ETS PTDP Port must remain in-service throughout the entire term commitment period of the associated ETS PTDP.

The monthly rates for the committed ETS PTDP Port and associated eligible ETS elements are set forth in Sections 17.4.8(C)(1) through (C)(6), following, or when applicable, as specified in Section 17.4.8(C)(9), following. ETS PTDPs are only available from those Telephone Companies listed in Section 17.3.10(A)(1), following.

Certain material formerly found on this page now appears on 5th Revised Page 16-74.

Transmittal No. 1532

Issued: November 16, 2017

Effective: December 1, 2017

Director - Access Tariffs
80 So. Jefferson Road, Whippany, NJ 07981

(N)

(N)

ACCESS SERVICE

16. Public Packet Data Network (Cont'd)16.3 Ethernet Transport Service (Cont'd)16.3.6 ETS Port Term Discount Plan (Cont'd)

The term discount percentage for the customer selected term commitment period applies to the committed ETS Port and the following associated eligible ETS elements when provided within the Telephone Company's operating territory: 1) ETS Channel Terminations (ETS CTs); 2) ETS Ethernet Virtual Connections (ETS EVCs) and associated Class of Service (CoS) levels, where applicable; 3) ETS Extended Ethernet Virtual Connections (ETS E-EVCs); 4) ETS Interconnected Ethernet Virtual Connections (ETS I-EVCs); 5) ETS MultiMedia Virtual Circuit Channels (ETS MM-VCCs); 6) ETS Low Bit Rate Virtual Circuit Channels (ETS LBR-VCCs); 7) the ETS Bandwidth Add-On (ETS BAO) feature; and 8) the ETS Port Protection feature. Customer ordered additions, disconnects or changes to the number of and/or bandwidth capacities for ETS CTs, ETS EVCs, ETS E-EVCs, ETS I-EVCs, ETS MM-VCCs, ETS LBR-VCCs, ETS BAO features and ETS Port Protection features associated with a committed ETS Port may be made at any time during the term commitment period and do not affect the customer's ETS PTDP.

The ETS PTDP term discount percentage does not apply to: 1) an ETS Port ordered on a month-to-month basis or committed under an ETS TDP term commitment; 2) ETS CTs, ETS EVCs and associated CoS levels, where applicable, ETS E-EVCs, ETS I-EVCs, ETS MM-VCCs, ETS LBR-VCCs, ETS BAO features, and ETS Port Protection features that are not associated with a committed ETS PTDP Port; 3) ETS nonrecurring charges; and 4) special access services connected to an ETS Interconnection Port.

When an eligible ETS element (i.e., ETS EVCs and associated CoS levels, ETS E-EVCs, ETS I-EVCs, and the ETS BAO) is ordered between two committed ETS PTDP Ports or between a committed ETS TDP Port and a committed ETS PTDP Port that have different term commitment lengths (e.g., one Port is committed for 36 months and the other Port is committed for 60 months), the Telephone Company will apply the discount percentage associated with the longer term commitment length (i.e., 60 months) to such eligible ETS element.

(C)
(C)

Transmittal No. 1539

Issued: February 14, 2018

Effective: March 1, 2018

Director - Access Tariffs
80 So. Jefferson Road, Whippany, NJ 07981

ACCESS SERVICE

16. Public Packet Data Network (Cont'd)

16.3 Ethernet Transport Service (Cont'd)

16.3.6 ETS Port Term Discount Plan (Cont'd)

(N)

The term discount percentage set forth in Section 17.4.8(C)(11), following, will not be subject to Telephone Company initiated decreases during the customer's selected term commitment period. If a term discount percentage increase occurs during the term commitment period, the increased percentage will be applied automatically for the remainder of the customer's existing term commitment period.

At the end of each ETS PTDP term commitment period, the customer may subscribe to a new ETS PTDP or revert to the undiscounted monthly rates and nonrecurring charges specified in Sections 17.4.8(C)(1) through (C)(6), following. If the customer does not notify the Telephone Company in writing of its choice by the end of its existing term commitment period, the Telephone Company will automatically convert the customer's ETS billing to the undiscounted monthly rates and nonrecurring charges specified in Sections 17.4.8(C)(1) through (C)(6), following. A customer is not eligible to subscribe to a new ETS TDP once it has subscribed to one or more individual ETS PTDPs.

An Access Order Charge as described in Section 5.4.1, preceding, does not apply to establish a new or make any changes to an existing ETS PTDP or when at the end of its existing term commitment period, the customer subscribes to a new ETS PTDP or reverts to undiscounted monthly rates and nonrecurring charges specified in Sections 17.4.8(C)(1) through (C)(6), following.

Except as specified in (A)-(B), below, discontinuance charges will apply when the customer fails to satisfy the term commitment period.

(N)

Certain material formerly found on this page now appears on 2nd Revised Page 16-74.2.

Transmittal No. 1532

Issued: November 16, 2017

Effective: December 1, 2017

Director - Access Tariffs
80 So. Jefferson Road, Whippany, NJ 07981

ACCESS SERVICE

16. Public Packet Data Network (Cont'd)16.3 Ethernet Transport Service (Cont'd)16.3.6 ETS Port Term Discount Plan (Cont'd)

(N)

(A) Committed ETS PTDP Port Replacement

At any time during the current term commitment period the customer may disconnect an existing committed ETS PTDP Port and replace it with a newly installed committed ETS PTDP Port at any available bandwidth capacity and any location within the Telephone Company's operating territory. The current term commitment period remains uninterrupted. For example, during the 20th month of a 36 month term commitment period, the ETS customer places orders to disconnect its existing 100 Mbps committed ETS PTDP Port and install a new 50 Mbps committed ETS PTDP Port. The newly committed 50 Mbps replacement ETS PTDP Port must remain in service for the remainder of the original 36 month ETS PTDP term commitment period.

The Telephone Company will waive the discontinuance charge as described in (C), below, and any unsatisfied minimum service period charge as described in Section 16.3.4(C), preceding, that may otherwise be applicable provided the customer's orders for the disconnection of the existing committed ETS PTDP Port and installation of the newly committed replacement ETS PTDP Port are submitted to the Telephone Company at the same time and include cross references as described in Section 5.2.8(E), preceding.

An E-rate eligible school, library or consortium may transfer an in-service committed ETS PTDP Port before the end of its existing term commitment period to its ETS E-Rate Option (ETS ERO) commitment without the application of a discontinuance charge as described in (C), below. An Access Order Charge will not apply to the customer's order for the transfer of the in-service committed ETS PTDP Port under the ETS PTDP to the customer's ETS ERO commitment. Availability of and eligibility for the ETS ERO are as specified in Section 16.3.8, following.

(N)

Certain material previously found on this page now appears on Original Page 16-74.3.

Transmittal No. 1532

Issued: November 16, 2017

Effective: December 1, 2017

Director - Access Tariffs
80 So. Jefferson Road, Whippany, NJ 07981

ACCESS SERVICE

16. Public Packet Data Network (Cont'd)16.3 Ethernet Transport Service (Cont'd)16.3.6 ETS Port Term Discount Plan (Cont'd)(A) Committed ETS PTDP Port Replacement (Cont'd)

An eligible rural health care provider may transfer an in-service committed ETS PTDP Port before the end of its existing term commitment period to its ETS Rural Health Care-Rate Option (ETS RHC-RO) commitment without the application of a discontinuance charge as described in (C), below. An Access Order Charge will not apply to the customer's order for the transfer of the in-service committed ETS PTDP Port under the ETS PTDP to the customer's ETS RHC-RO commitment. Availability of and eligibility for the ETS RHC-RO are as specified in Section 16.3.9, following.

(N)

(N)

(B) ETS PTDP Replacement

At any time during the term commitment period the customer may replace an existing ETS PTDP with a new 36 or 60 month ETS PTDP commitment for an ETS PTDP Port at any available bandwidth capacity and any location within the Telephone Company's operating territory. For example, an existing ETS PTDP may be replaced in the 22nd month of a 60 month term commitment period with a new replacement ETS PTDP for 36 months. The term discount percentage applicable for the replacement ETS PTDP will apply on a going forward basis. The customer's written request to establish a new replacement ETS PTDP should indicate the new 36 or 60 month term commitment period and the selected bandwidth capacity and location within the Telephone Company's operating territory for the newly committed replacement ETS PTDP Port. The Telephone Company will waive the discontinuance charge as described in (C), below, and any unsatisfied minimum service period charge as specified in Section 16.3.4(C), preceding, that may otherwise be applicable.

Transmittal No. 1646

Issued: October 15, 2021

Effective: October 30, 2021

Director - Access Tariff Development
60 Columbia Road, Bldg. A - 2nd Fl., Morristown, NJ 07960

ACCESS SERVICE

(N)

16. Public Packet Data Network (Cont'd)16.3 Ethernet Transport Service (Cont'd)16.3.6 ETS Port Term Discount Plan (Cont'd)(C) Discontinuance Charges

Except as provided for in (A)-(B), above, a discontinuance charge will apply when a customer disconnects a committed ETS Port prior to the end of its ETS PTDP term commitment period. The discontinuance charge will be equal to 35% of the total undiscounted monthly rate for the committed ETS Port for each month remaining in the unsatisfied term commitment period. For example, a customer discontinues its 100 Mbps ETS Basic Port in the 20th month of a 36 month term commitment period. Using an illustrative undiscounted monthly rate of \$330 for a 100 Mbps ETS Basic Port, the Telephone Company will bill the customer a port discontinuance charge of \$1,848 (i.e., \$330.00 x 35% x 16 months). A minimum service period charge as specified in Section 16.3.4(C), preceding, would also apply, if applicable.

(D) ETS PTDP Volume Discount Plan

The ETS PTDP Volume Discount Plan (ETS PTDP VDP) is an optional pricing plan that provides the ETS PTDP customer with an additional discount applied against the monthly charges for its committed ETS Basic and Interconnection Ports when the customer has at least five committed ETS PTDP Ports in-service within the Telephone Company's operating territory on the first of each month. At the same time it subscribes to its ETS PTDP or any time thereafter, the customer may notify the Telephone Company in writing it wants to establish an ETS PTDP VDP.

(N)

Transmittal No. 1532

Issued: November 16, 2017

Effective: December 1, 2017

Director - Access Tariffs
80 So. Jefferson Road, Whippany, NJ 07981

ACCESS SERVICE

(N)

16. Public Packet Data Network (Cont'd)16.3 Ethernet Transport Service (Cont'd)16.3.6 ETS Port Term Discount Plan (Cont'd)(D) ETS PTDP Volume Discount Plan (Cont'd)

On the 1st of each month, the Telephone Company will determine the number of committed ETS Basic and Interconnection Ports in-service under the customer's individual ETS PTDPs. If five or more committed ETS PTDP Ports are in-service on that date, the ETS PTDP VDP discount will be applied for that month to all committed ETS PTDP Ports in-service. If the customer does not have at least five committed ETS PTDP Ports in-service on the first of the month, it will not be eligible for the ETS PTDP VDP discount for that particular month. When applicable, the ETS PTDP VDP discount will be applied after the ETS PTDP term discount is applied.

The ETS PTDP VDP discount does not apply to: (1) ETS Ports ordered on a month-to-month basis or committed under an ETS TDP term commitment (i.e., non-committed ETS PTDP Ports), (2) any other ETS monthly charges, (3) any ETS nonrecurring charges, or (4) any monthly or nonrecurring charges for special access services connected to a committed ETS Interconnection Port. Access Order Charges as described in Section 5.4.1, preceding, do not apply to establish a new ETS PTDP VDP or to terminate an existing ETS PTDP VDP.

The ETS PTDP VDP discount is specified in Section 17.4.8(C)(12), following.

(N)

Transmittal No. 1532

Issued: November 16, 2017

Effective: December 1, 2017

Director - Access Tariffs
80 So. Jefferson Road, Whippany, NJ 07981

ACCESS SERVICE

16. Public Packet Data Network (Cont'd)

16.3 Ethernet Transport Service (Cont'd)

16.3.7 ETS Fixed Rate Option

Where offered, the ETS Fixed Rate Option (ETS FRO) provides the customer with stabilized rates that will apply to the customer's ETS service elements throughout the length of the customer's selected term commitment period when subscribed to an ETS Term Discount Plan (ETS TDP) as specified in Section 16.3.5, preceding, or one or more individual ETS Port Term Discount Plans (ETS PTDPs) as specified in Section 16.3.6, preceding.

(T) (M)

(C) (M)

(C)

When the customer subscribes to an ETS FRO, the stabilized rates for the ETS service elements included under an ETS FRO plan will not be subject to any Telephone Company initiated rate increases and decreases during the customer's selected term commitment period.

(M)

The ETS FRO is only available from those Telephone Companies listed in Section 17.4.8(C) (9), following, which offer the ETS FRO during the availability window specified.

The ETS FRO is only available when the customer establishes a new 36 month or 60 month ETS TDP or ETS PTDP term commitment with the Telephone Company. An existing ETS TDP or ETS PTDP customer wishing to subscribe to an available ETS FRO may replace its existing term commitment with a new 36 month or 60 month ETS term commitment. If applicable, minimum service period charges, commitment shortfall charges, and/or discontinuance charges as described in Sections 16.3.5(C) and (D) or 16.3.6(B) and (C), preceding, would apply to the customer's ETS TDP or ETS PTDP being replaced, and would be calculated using the monthly rates specified in Sections 17.4.8(C) (1) through (C) (6), following.

(T)

(C)

(C)

(T)

(T)

(C)

(C)

(M)

Certain material currently found on this page previously appeared on 2nd Revised Page 16-73.

Certain material formerly found on this page now appears on 4th Revised Page 16-75 and Original Page 16-75.1.

Transmittal No. 1532

Issued: November 16, 2017

Effective: December 1, 2017

Director - Access Tariffs
80 So. Jefferson Road, Whippany, NJ 07981

ACCESS SERVICE

16. Public Packet Data Network (Cont'd)

16.3 Ethernet Transport Service (Cont'd)

16.3.7 ETS Fixed Rate Option (Cont'd)

(T) (M)

In order to subscribe to an available ETS FRO, the customer must notify the Telephone Company in writing during the time period specified in that ETS FRO plan that it wishes to establish a new 36 month or 60 month ETS TDP or ETS PTDP with ETS FRO stabilized rates.

(C)

The stabilized rates specified in Section 17.4.8(C)(9), following, for an available ETS FRO apply in lieu of the non-stabilized rates specified in Sections 17.4.8(C)(1) through (C)(6), following. The ETS FRO stabilized rates will apply to the customer's ETS service elements only during the 36 month or 60 month commitment period established by the customer at the time it subscribes to the ETS FRO plan.

Except as provided herein, all other provisions related to the ETS TDP or ETS PTDP as specified in Sections 16.3.5 and 16.3.6, preceding, apply to a customer that subscribes to an ETS FRO plan.

(C)

(C)

A customer with ETS FRO stabilized rates may replace or discontinue its ETS TDP or ETS PTDP at any time during its selected term commitment period subject to the provisions described in Sections 16.3.5(C) and (D) or 16.3.6(B) and (C), preceding. If applicable, minimum service period charges, commitment shortfall charges, or discontinuance charges as described in Sections 16.3.5(C) and (D) or 16.3.6(B) and (C), preceding, would apply and would be calculated using the monthly rates specified in the ETS FRO plan to which the customer subscribed.

(T)

(C)

(C)

(T)

(C)

(C)

(M)

Certain material currently found on this page previously appeared on 1st Revised Page 16.73.1

Certain material formerly found on this page now appears on Original Pages 16-75.1 and 16-75.2.

Transmittal No. 1532

Issued: November 16, 2017

Effective: December 1, 2017

Director - Access Tariffs
80 So. Jefferson Road, Whippany, NJ 07981

ACCESS SERVICE

16. Public Packet Data Network (Cont'd)

16.3 Ethernet Transport Service (Cont'd)

16.3.7 ETS Fixed Rate Option (Cont'd)

(T)

A customer with ETS FRO stabilized rates may not renew or extend its ETS FRO plan subscription beyond the end of the term commitment period selected at the time it subscribed to the ETS FRO plan. At the end of the customer's term commitment period, a customer with ETS FRO stabilized rates may choose to:

(T) (M)

(T)

- subscribe to a new ETS TDP or ETS PTDP commitment period with the monthly rates and nonrecurring charges specified in Sections 17.4.8(C)(1) through (C)(6), following;

(C)

- subscribe to a new ETS TDP or ETS PTDP commitment period with ETS FRO stabilized rates, if an alternative ETS FRO plan is available at that time, as specified in Section 17.4.8(C)(9), following; or

(C)

- revert to the undiscounted monthly rates and nonrecurring charges specified in Sections 17.4.8(C)(1) through (C)(6), following.

If the customer does not notify the Telephone Company in writing of its choice by the end of its existing term commitment period, the Telephone Company will automatically convert the customer's ETS billing for current and future ETS service elements to the monthly rates and nonrecurring charges specified in Sections 17.4.8(C)(1) through (C)(6), following.

(M)

Certain material currently found on this page previously appeared on 1st Revised Page 16-73.2.

Certain material formerly found on this page now appears on Original Page 16-75.2.

Transmittal No. 1532

Issued: November 16, 2017

Effective: December 1, 2017

Director - Access Tariffs
80 So. Jefferson Road, Whippany, NJ 07981

ACCESS SERVICE

16. Public Packet Data Network (Cont'd)

16.3 Ethernet Transport Service (Cont'd)

16.3.7 ETS Fixed Rate Option (Cont'd)

An Access Order Charge does not apply to establish a new or discontinue an existing ETS FRO. An Access Order Charge also does not apply when at the end of the customer's ETS TDP or ETS PTDP the customer subscribes to a new ETS TDP or ETS PTDP or reverts to billing using the undiscounted monthly rates and nonrecurring charges specified in Sections 17.4.8(C) (1) through (C) (6), following.

(N)

(N)

(T) (M)

(C)

(C)

(M)

Certain material currently found on this page previously appeared on Original Page 16-73.3.

Transmittal No. 1532

Issued: November 16, 2017

Effective: December 1, 2017

Director - Access Tariffs
80 So. Jefferson Road, Whippany, NJ 07981

ACCESS SERVICE

16. Public Packet Data Network (Cont'd)

16.3 Ethernet Transport Service (Cont'd)

16.3.8 ETS E-Rate Option

(T) (M)

(A) General

The ETS E-Rate Option (ETS ERO) is a specialized pricing plan designed specifically to help stimulate broadband adoption by E-rate eligible schools, libraries, or consortia.

The ETS ERO is available for subscription only from those Telephone Companies listed in Section 17.4.8(C)(10), following, during the defined Plan Year. The ETS ERO provides Telephone Company specific discounted, stabilized monthly rates on committed ETS service elements provided to a qualified E-rate eligible school, library or consortium during the defined Plan Year. The ETS ERO Telephone Company specific rates specified in Section 17.4.8(C)(10), following, apply in lieu of the non-stabilized monthly rates specified in Sections 17.4.8(C)(1) through (C)(6), following. Nonrecurring charges are not rate stabilized under the ETS ERO. When a customer subscribes to an available ETS ERO, the Telephone Company specific stabilized rates for the ETS service elements included under that ETS ERO will not be subject to any Telephone Company initiated rate increases and decreases for the duration of the defined Plan Year.

To be eligible to subscribe to an available ETS ERO, a customer must:

- be an E-rate eligible school, library or consortium as defined in Title 47, Part 54, Subpart F, Sections 54.500 and 54.501, and
- have a FCC Form 470 on the Universal Service Administrative Company's (USAC's) website requesting Category One data transmission services and Internet access that can be satisfied using Ethernet Transport Services provided by the Telephone Company under Tariff No. 5.

(M)

Certain material currently found on this page previously appeared on 4th Revised Page 16-74.

Certain material formerly found on this page now appears on Original Page 16-75.3.

Transmittal No. 1532

Issued: November 16, 2017

Effective: December 1, 2017

Director - Access Tariffs
 80 So. Jefferson Road, Whippany, NJ 07981

ACCESS SERVICE

16. Public Packet Data Network (Cont'd)16.3 Ethernet Transport Service (Cont'd)16.3.8 ETS E-Rate Option (Cont'd)(B) Rate Regulations

(T)

Upon receipt of a customer's written request to subscribe to an available ETS ERO, the Telephone Company will determine the customer's eligibility by verifying the existence of the required, qualifying FCC Form 470 on USAC's website (<http://www.usac.org>) for the Plan Year.

An Access Order Charge as described in Section 5.4.1, preceding, does not apply to the initial subscription of an available ETS ERO.

The ETS service elements, including optional features, available for installation at E-rate eligible school, library or consortium locations within the Telephone Company's serving territory are specified in Section 17.4.8(C) (10), following, for the specified Plan Year. ETS service element descriptions are identified in Section 16.3.4, preceding. At any time during the defined Plan Year, the ETS ERO customer may: (1) order the installation of new committed ETS service elements and/or (2) request in-service ETS service elements be committed to the ETS ERO to take advantage of the ETS ERO stabilized monthly rates. When an ETS ERO customer installs new committed ETS service elements during the course of the defined Plan Year, an Access Order Charge and nonrecurring charges will apply for the newly installed elements. When the ETS ERO customer requests in-service ETS service elements be committed to the ETS ERO, the Access Order Charge and nonrecurring charges will not apply.

Transmittal No. 1653

Issued: January 14, 2022

Effective: January 29, 2022

Director - Access Tariff Development
60 Columbia Road, Bldg. A - 2nd Fl., Morristown, NJ 07960

ACCESS SERVICE

16. Public Packet Data Network (Cont'd)

16.3 Ethernet Transport Service (Cont'd)

16.3.8 ETS E-Rate Option (Cont'd)

(B) Rate Regulations (Cont'd)

Any ETS service element included in the customer's ETS ERO must remain in-service from the time it is placed under the ETS ERO through the end of the defined Plan Year. Any committed ETS service element disconnected during the defined Plan Year will be subject to a discontinuance charge. The discontinuance charge will be equal to 20% of the ETS ERO Telephone Company specific monthly rate for each disconnected ETS service element for each month remaining in the defined Plan Year. Should a customer disconnect all of its committed ETS service elements, effectively terminating its subscription to the ETS ERO, it will not be permitted to re-subscribe to the ETS ERO during the same Plan Year.

A customer may replace an existing ETS ERO at any time during the current Plan Year with a new ETS ERO for the following Plan Year, if one is available, without the application of discontinuance charges provided all the committed ETS service elements under the existing ETS ERO are transferred to the new ETS ERO. For example, a customer subscribed to an existing ETS ERO for Plan Year 2016 places an order on April 1, 2017 to replace its existing ETS ERO with a new ETS ERO for Plan Year 2017 and transfers all committed ETS service elements under the existing ETS ERO Plan Year 2016 to the new ETS ERO Plan Year 2017. An Access Order Charge will not apply when a customer replaces its existing ETS ERO prior to the end of the current Plan Year with a new ETS ERO for the following Plan Year.

(N)

(N)

(T) (M)

(M)

Certain material currently found on this page previously appeared on 3rd Revised Page 16-74.1 and 1st Revised Page 16-74.2.

Transmittal No. 1532

Issued: November 16, 2017

Effective: December 1, 2017

Director - Access Tariffs
80 So. Jefferson Road, Whippany, NJ 07981

ACCESS SERVICE

16. Public Packet Data Network (Cont'd)

16.3 Ethernet Transport Service (Cont'd)

16.3.8 ETS E-Rate Option (Cont'd)

(B) Rate Regulations (Cont'd)

A customer may not renew or extend an existing ETS ERO beyond the end of the defined Plan Year. The Telephone Company will notify the ETS ERO customer in writing 90 days prior to the end of the current Plan Year that the customer's ETS ERO is due to expire at the end of the current Plan Year. The ETS ERO customer must notify the Telephone Company in writing at least 30 days prior to the end of the current Plan Year of its decision to:

- subscribe to a new ETS E-Rate Option, if one is available; or
- subscribe to a new ETS Term Discount Plan commitment period as specified in Section 16.3.5, preceding;
- subscribe to individual ETS Port Term Discount Plan commitment periods as specified in Section 16.3.6, preceding; or
- revert to the non-stabilized, undiscounted monthly rates and nonrecurring charges specified in Sections 17.4.8(C)(1) through (C)(6), following.

(C)
|
(C)

If the customer does not notify the Telephone Company in writing at least 30 days prior to the end of the current Plan Year, the Telephone Company will automatically convert the customer's committed ETS service elements provided under the ETS ERO to the non-stabilized, undiscounted monthly rates specified in Sections 17.4.8(C)(1) through (C)(6), following, beginning the day after the current Plan Year ends. An Access Order Charge will not apply when a customer at the end of the current Plan Year subscribes to a new ETS ERO, a new ETS Term Discount Plan, new individual ETS Port Term Discount Plans or is converted to month-to-month billing using the non-stabilized, undiscounted monthly rates and nonrecurring charges specified in Sections 17.4.8(C)(1) through (C)(6), following.

(C)
(C)

Transmittal No. 1539

Issued: February 14, 2018

Effective: March 1, 2018

Director - Access Tariffs
 80 So. Jefferson Road, Whippany, NJ 07981

ACCESS SERVICE

16. Public Packet Data Network (Cont'd)

16.3 Ethernet Transport Service (Cont'd)

16.3.8 ETS E-Rate Option (Cont'd)

(B) Rate Regulations (Cont'd)

Except as provided herein, all provisions specified in Section 16.3.4 (Rate Regulations), preceding, apply to ETS service elements included in the ETS ERO for the specified Plan Year. Minimum service period requirements specified in Section 16.3.4(C), preceding, are waived on all committed ETS service elements placed under the ETS ERO. Any ETS service element committed under the ETS ERO cannot also be committed under any other term or discount plan available for ETS, i.e., ETS Term Discount Plan or ETS Port Term Discount Plan.

(C)

Transmittal No. 1561

Issued: November 16, 2018

Effective: December 1, 2018

Director - Access Tariffs
80 So. Jefferson Road, Whippany, NJ 07981

ACCESS SERVICE

16. Public Packet Data Network (Cont'd)16.3 Ethernet Transport Service (Cont'd)16.3.9 ETS Rural Health Care-Rate Option(A) General

The ETS Rural Health Care-Rate Option (ETS RHC-RO) is a specialized pricing plan available to eligible rural health care provider customers to support the need for broadband connectivity for telehealth/telemedicine applications in rural areas.

The ETS RHC-RO is available for subscription only from those Telephone Companies listed in Section 17.4.8(C)(13), following, during the defined Plan Year. The ETS RHC-RO provides Telephone Company specific stabilized, discounted monthly rates on committed ETS service elements provided to a qualified eligible rural health care provider during the defined Plan Year. The ETS RHC-RO Telephone Company specific stabilized, discounted monthly rates specified in Section 17.4.8(C)(13), following, apply in lieu of the non-stabilized monthly rates specified in Sections 17.4.8(C)(1) through (C)(6), following. When a customer subscribes to an available ETS RHC-RO, the Telephone Company specific stabilized, discounted monthly rates for the ETS service elements included under the ETS RHC-RO will not be subject to any Telephone Company initiated rate increases and decreases for the duration of the defined Plan Year. Nonrecurring charges are not rate stabilized under the ETS RHC-RO.

To subscribe to an available ETS RHC-RO, a customer must:

- be an eligible rural health care provider as defined in Title 47, Part 54, Subpart G, Sections 54.600 and 54.601, and
- have submitted FCC Forms 461 (Healthcare Connect Fund Program) and/or 465 (Telecommunications Program) to the Universal Service Administrative Company's (USAC's) website requesting Category One data transmission services and Internet access that can be satisfied using Ethernet Transport Services provided by the Telephone Company under Tariff No. 5.

Transmittal No. 1646

Issued: October 15, 2021

Effective: October 30, 2021

Director - Access Tariff Development
60 Columbia Road, Bldg. A - 2nd Fl., Morristown, NJ 07960

(N)

(N)

ACCESS SERVICE

16. Public Packet Data Network (Cont'd)

16.3 Ethernet Transport Service (Cont'd)

16.3.9 ETS Rural Health Care-Rate Option (Cont'd)

(B) Rate Regulations

Upon receipt of a customer's written request to subscribe to an available ETS RHC-RO, the Telephone Company will determine the customer's eligibility by verifying the rural health care provider's request for services on USAC's website (<http://www.usac.org>) for the defined Plan Year.

An Access Order Charge as described in Section 5.4.1, preceding, does not apply to the initial subscription of an available ETS RHC-RO.

The ETS service elements, including optional features, available for installation within the Telephone Company's serving territory at eligible rural health care provider locations (as defined in Title 47, Part 54, Subpart G, Section 54.600) are specified in Section 17.4.8(C) (13), following, for the defined Plan Year. ETS service element descriptions are identified in Section 16.3.4, preceding.

At any time during the defined Plan Year, the customer may: (1) order the installation of new committed ETS service elements and/or (2) request in-service ETS service elements be committed to the ETS RHC-RO to take advantage of the ETS RHC-RO stabilized, discounted monthly rates. When a customer commits new ETS service elements during the course of the defined Plan Year, an Access Order Charge and nonrecurring charges will apply for the newly installed service elements. When the customer requests in-service ETS service elements be committed to the ETS RHC-RO, the Access Order Charge and nonrecurring charges will not apply.

Transmittal No. 1646

Issued: October 15, 2021

Effective: October 30, 2021

Director - Access Tariff Development
60 Columbia Road, Bldg. A - 2nd Fl., Morristown, NJ 07960

(N)

(N)

ACCESS SERVICE

(N)

16. Public Packet Data Network (Cont'd)

16.3 Ethernet Transport Service (Cont'd)

16.3.9 ETS Rural Health Care-Rate Option (Cont'd)

(B) Rate Regulations (Cont'd)

Any ETS service element included in the customer's ETS RHC-RO must remain in-service from the time it is placed under the ETS RHC-RO through the end of the defined Plan Year. Any committed ETS service element disconnected during the defined Plan Year will be subject to a discontinuance charge. The discontinuance charge will be equal to 20% of the ETS RHC-RO Telephone Company specific stabilized, discounted monthly rate under the ETS RHC-RO and not the Telephone Company standard monthly rate for each disconnected ETS service element for each month remaining in the defined Plan Year. Should a customer disconnect all of its committed ETS service elements, effectively terminating its subscription to the ETS RHC-RO, it will not be permitted to re-subscribe to the ETS RHC-RO during the same defined Plan Year.

A customer may replace an existing ETS RHC-RO at any time during the current Plan Year with a new ETS RHC-RO for the following Plan Year, if one is available, without the application of discontinuance charges provided all the committed ETS service elements under the existing ETS RHC-RO are transferred to the new ETS RHC-RO. An Access Order Charge will not apply when a customer replaces its existing ETS RHC-RO prior to the end of the current Plan Year with a new ETS RHC-RO for the following Plan Year.

(N)

Transmittal No. 1646

Issued: October 15, 2021

Effective: October 30, 2021

Director - Access Tariff Development
60 Columbia Road, Bldg. A - 2nd Fl., Morristown, NJ 07960

ACCESS SERVICE

16. Public Packet Data Network (Cont'd)16.3 Ethernet Transport Service (Cont'd)16.3.9 ETS Rural Health Care-Rate Option (Cont'd)(B) Rate Regulations (Cont'd)

A customer may not renew or extend an existing ETS RHC-RO beyond the end of the defined Plan Year. The Telephone Company will notify the customer in writing 90 days prior to the end of the current Plan Year that the customer's ETS RHC-RO is due to expire at the end of the current Plan Year. The customer must notify the Telephone Company in writing at least 30 days prior to the end of the current Plan Year of its decision to:

- subscribe to a new ETS RHC-RO Plan Year, if one is available; or
- subscribe to a new ETS Term Discount Plan commitment period as specified in Section 16.3.5, preceding;
- subscribe to individual ETS Port Term Discount Plan commitment periods as specified in Section 16.3.6, preceding; or
- revert to the non-stabilized, undiscounted monthly rates and nonrecurring charges specified in Sections 17.4.8(C)(1) through (C)(6), following.

If the customer does not notify the Telephone Company in writing at least 30 days prior to the end of the current Plan Year, the Telephone Company will automatically convert the customer's committed ETS service elements provided under the ETS RHC-RO to the non-stabilized, undiscounted monthly rates specified in Sections 17.4.8(C)(1) through (C)(6), following, beginning the day after the current Plan Year ends. An Access Order Charge will not apply when a customer at the end of the current Plan Year subscribes to a new ETS RHC-RO, a new ETS Term Discount Plan, new individual ETS Port Term Discount Plans or is converted to month-to-month billing using the non-stabilized, undiscounted monthly rates and nonrecurring charges specified in Sections 17.4.8(C)(1) through (C)(6), following.

Transmittal No. 1646

Issued: October 15, 2021

Effective: October 30, 2021

Director - Access Tariff Development
60 Columbia Road, Bldg. A - 2nd Fl., Morristown, NJ 07960

(N)

(N)

ACCESS SERVICE

16. Public Packet Data Network (Cont'd)

16.3 Ethernet Transport Service (Cont'd)

16.3.9 ETS Rural Health Care-Rate Option (Cont'd)

(B) Rate Regulations (Cont'd)

Except as provided herein, all provisions specified in Section 16.3.4 (Rate Regulations), preceding, apply to ETS service elements included in the ETS RHC-RO for the defined Plan Year. Minimum service period requirements specified in Section 16.3.4(C), preceding, are waived on all committed ETS service elements placed under the ETS RHC-RO. An ETS service element committed under the ETS RHC-RO cannot also be committed under any other term or discount plan available for ETS, i.e., ETS Term Discount Plan or ETS Port Term Discount Plan.

(N)

(N)

Transmittal No. 1646

Issued: October 15, 2021

Effective: October 30, 2021

Director - Access Tariff Development
60 Columbia Road, Bldg. A - 2nd Fl., Morristown, NJ 07960

ACCESS SERVICE

(N)

16. Public Packet Data Network (Cont'd)16.3 Ethernet Transport Service (Cont'd)16.3.10 ETS PackagesGeneral

ETS Packages contain combinations of individual ETS rate elements and may be ordered in place of individual ETS rate elements. Combining ETS rate elements into ETS Packages provides the customer with ease of ordering. ETS Packages are offered wherever ETS service is available as identified in the NATIONAL EXCHANGE CARRIER ASSOCIATION, INC. Tariff F.C.C. No. 4.

Rate Categories

The pricing for an ETS Package includes the monthly and non-recurring charges for ETS Channel Terminations (CTs) and ETS Basic Ports, and when applicable an ETS Extended-Ethernet Virtual Connection (ETS E-EVC) into one Package. ETS Packages are available at bandwidth speeds of 100 Mbps, 1 Gbps, 2.5 Gbps, 5 Gbps and 10 Gbps. Rates and charges for ETS Packages are specified in Section 17.4.8 (C) (14), following. The various ETS Packages are described below.

- (1) ETS Package 1 includes one Port and one CT located within 300 feet of the ETS SWC.
- (2) ETS Package 2 includes one Port and one CT located greater than 300 feet from the ETS SWC.
- (3) ETS Package 3 includes one Port and one CT located within 300 feet of the ETS SWC with one E-EVC.
- (4) ETS Package 4 includes one Port and one CT located greater than 300 feet from the ETS SWC with one E-EVC.

Any EVC or optional feature applicable to ETS may be added as an individual rate element to Package 1 and Package 2 to complete the transmission path. Any optional feature applicable to ETS may be added as an individual rate element to Package 3 and Package 4 to complete the transmission path.

(N)

Transmittal No. 1713

Issued: February 15, 2024

Effective: March 1, 2024

Senior Director - Access Tariff Cost Development
60 Columbia Road, Bldg. A - 2nd Fl., Morristown, NJ 07960

ACCESS SERVICE

16. Public Packet Data Network (Cont'd)

Reserved for Future Use

(N)

Certain material formerly found on this page now appears on 2nd Revised Page 16-85.

Transmittal No. 1483

Issued: April 15, 2016

Effective: April 30, 2016

Director - Access Tariffs
80 So. Jefferson Road, Whippany, NJ 07981

ACCESS SERVICE

16. Public Packet Data Network (Cont'd)

Reserved for Future Use

(N)

Certain material formerly found on this page now appears on 1st Revised Page 16-86.

Transmittal No. 1483

Issued: April 15, 2016

Effective: April 30, 2016

Director - Access Tariffs
80 So. Jefferson Road, Whippany, NJ 07981